

W78E858 Data Sheet



8-BIT MICROCONTROLLER

Table of Contents-

1.	GENERAL DESCRIPTION	3
2.	FEATURES	3
3.	PIN CONFIGURATIONS	4
4.	PIN DESCRIPTION.....	5
5.	FUNCTIONAL DESCRIPTION	6
5.1	RAM	6
5.2	EEPROM	6
5.2.1	Byte Write Mode	6
5.2.2	Page Write Mode.....	6
5.2.3	Software Protected Data Write	7
5.2.4	Command Codes for Software Data Protection Enable/Disable and Software Erase.....	7
5.3	Demo Code:.....	8
5.4	On-chip Flash EPROM	10
5.5	Timers 0, 1, and 2.....	11
5.6	Clock.....	11
5.7	Crystal Oscillator.....	11
5.8	External Clock.....	11
5.9	Power Management.....	11
5.9.1	Idle Mode.....	11
5.9.2	Power-down Mode.....	11
5.9.3	Wake-up Via External Interrupts INT0 to INT9	12
5.10	Reset.....	13
5.11	Pulse Width Modulator System	15
5.11.1	PWMCON (91H).....	15
5.11.2	PWMP (92H)	15
5.12	In-system Programming System	16
5.12.1	SFRAL (C4H)	16
5.12.2	SFRAH (C5H).....	16
5.12.3	SFRFD (C6H).....	16
5.12.4	SFRCN (C7H).....	17
5.13	In-system Programming Mode Operating Table	17
5.13.1	CHPCON (BFH)	18
5.14	MXPSR (A2H).....	18
5.15	Interrupt System	18
5.16	External Interrupts INT2 to INT9.....	19
5.16.1	IE_1 (E8H).....	19



5.16.2	IP1 (F8H).....	19
5.16.3	IX1 (E9H).....	20
5.16.4	IRQ1 (C0H).....	20
5.16.5	Interrupt Priority and Vector Address.....	20
5.17	F04KBOOT Mode (Boot From 4K Bytes LDROM)	21
5.17.1	F04KBOOT Mode.....	21
5.18	Security	21
5.18.1	Lock Bit (Bit0)	22
5.18.2	MOVC Lock (Bit1).....	22
5.18.3	Scramble Enable (Bit2).....	22
5.18.4	Oscillator Gain Select (Bit7).....	22
5.19	Watch Dog Timer.....	23
5.19.1	WDTC (8FH)	23
5.20	Programmable Clock-out.....	24
5.21	Reduce EMI Emission	24
6.	ELECTRICAL CHARACTERISTICS.....	25
6.1	Absolute Maximum Ratings	25
6.2	D.C. Characteristics.....	25
6.3	A.C. Characteristics	27
6.3.1	Clock Input Waveform	27
6.3.2	Program Fetch Cycle.....	27
6.3.3	Data Read Cycle	28
6.3.4	Data Write Cycle.....	28
6.3.5	Port Access Cycle	28
6.3.6	Flash Mode Timing	28
7.	TIMING WAVEFORMS	29
7.1	Program Fetch Cycle	29
7.2	Data Read Cycle.....	29
7.3	Data Write Cycle	30
7.4	Port Access Cycle.....	30
8.	TYPICAL APPLICATION CIRCUITS	31
8.1	Expanded External Program Memory and Crystal	31
8.2	Expanded External Data Memory and Oscillator	32
9.	PACKAGE DIMENSIONS	33
9.1	40-pin DIP	33
9.2	44-pin PLCC	33
9.3	44-pin PQFP	34
10.	VERSION HISTORY	35



1. GENERAL DESCRIPTION

The W78E858 is an 8-bit microcontroller which has an in-system programmable Flash EPROM for firmware updating. The instruction set of the W78E858 is fully compatible with the standard 8052. The W78E858 contains a 32K bytes of main Flash EPROM and a 4K bytes of auxiliary Flash EPROM which allows the contents of the 32KB main Flash EPROM to be updated by the loader program located at the 4KB auxiliary Flash EPROM ROM; 768 bytes of on-chip RAM; 128 bytes of EEPROM, 8 extra power down wake-up through INT2 to INT9; 4 channel 8-bit PWM; four 8-bit bi-directional and bit-addressable I/O ports; an additional 4-bit port P4; three 16-bit timer/counters where the TIMER2 with programmable clock output and 17-bit watchdog timer are built in this device; a serial port. These peripherals are supported by a eight sources two-level interrupt capability. To facilitate programming and verification, the Flash EPROM inside the W78E858 allows the program memory to be programmed and read electronically. Once the code is confirmed, the user can protect the code for security.

2. FEATURES

- Fully static design 8-bit CMOS micro-controller up to 40 MHz
- 32K bytes of in-system programmable FLASH EPROM for Application Program (APROM)
- 4K bytes of auxiliary FLASH EPROM for Loader Program (LDROM)
- Low standby current at full supply voltage
- 256 + 512 bytes of on-chip RAM
- 128 bytes on-chip EEPROM memory
- 64K bytes program memory address space and 64K bytes data memory address space
- Four 8-bit bi-directional ports
- One 4-bit bi-directional port
- Extra interrupts INT2 to INT9 at PORT1
- Wake-up via external interrupts INT0 – INT9
- Three 16-bit timer/counters
- One full duplex serial port
- Fourteen-sources, two-level interrupt capability
- Programmable Timer2 clock output via P1.0
- 17-bits watchdog timer
- Four channels 8-bit PWM
- Built-in power management
- Code protection
- Packaged in PDIP 40 / PLCC 44 / PQFP 44



3. PIN CONFIGURATIONS

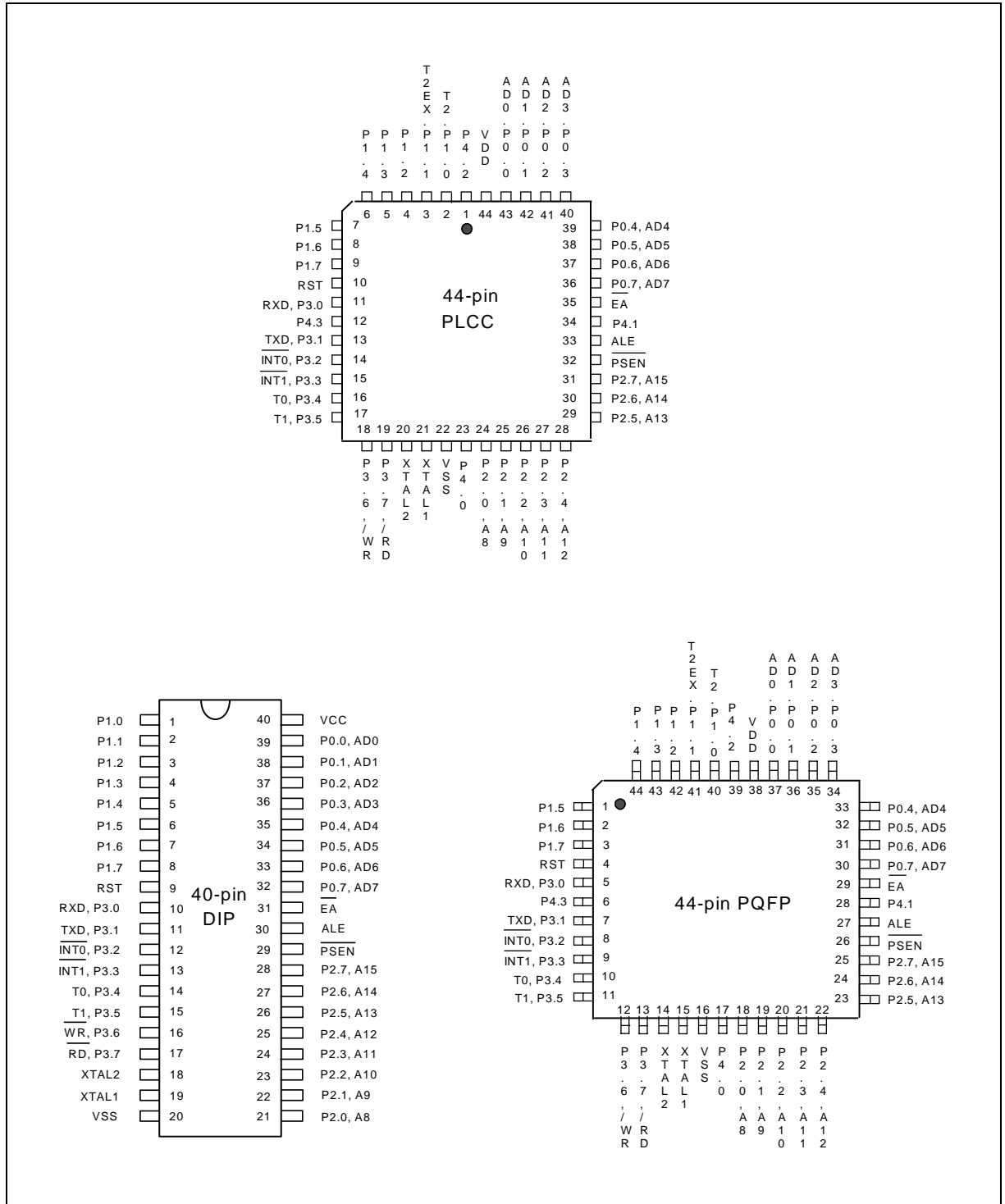



4. PIN DESCRIPTION

SYMBOL	TYPE	DESCRIPTIONS
\overline{EA}	I	External Access Enable: \overline{EA} low forces the processor to execute the external ROM. The ROM address and data will not be present on the bus if the \overline{EA} pin is high and the program counter is within the 32 KB area. Otherwise they will be present on the bus.
\overline{PSEN}	O/H	Program Strobe Enable: \overline{PSEN} enables the external ROM data in the Port 0 address/data bus. When internal ROM access is performed, no \overline{PSEN} strobe signal outputs originate from this pin.
ALE	O/H	Address Latch Enable: ALE is used to enable the address latch that separates the address from the data on Port 0. ALE runs at 1/6th of the oscillator frequency. An ALE pulse is omitted during external data memory accesses.
RST	I/L	RESET: A high on this pin for two machine cycles while the oscillator is running resets the device. RST has a Schmitt trigger input stage to provide additional noise immunity with a slow rising input voltage.
XTAL1	I	Crystal 1: This is the crystal oscillator input. This pin may be driven by an external clock
XTAL2	O	Crystal 2: This is the crystal oscillator output. It is the inversion of XTAL1.
VSS	I	Ground: Ground potential.
VDD	I	Power Supply: Supply voltage for operation.
P0.0 – P0.7	I/O D	Port 0: Function is the same as that of the standard 8052.
P1.0 – P1.7	I/O H	Port 1: Function is the same as that of the standard 8052. Port1 also service the alternative function INT2 – INT9. P1.0 provide a timer2 programmable clock output. Four channel PWM clock output via P1.4 – P1.7
P2.0 – P2.7	I/O H	Port 2: Port 2 is a bi-directional I/O port with internal pull-ups and emits the high-order address byte during accesses external memory
P3.0 – P3.7	I/O H	Port 3: Function is the same as that of the standard 8052
P4.0 – P4.3	I/O H	Port 4: Function is the same as Port1

* **Note:** TYPE I: input, O: output, I/O: bi-directional, H: pull-high, L: pull-low, D: open drain



5. FUNCTIONAL DESCRIPTION

The W78E858 architecture consists of a core controller surrounded by various registers, four 8-bit general purpose I/O ports, one 4-bits general purpose I/O port, 256 bytes data RAM and 512 bytes auxiliary RAM, 128 bytes embedded EEPROM memory, three timer/counters, one serial port, 17-bit watch-dog timer, 8-bit four channels PWM, programmable timer2 clock output, extra external interrupts INT2 to INT9, power-down wake up via external interrupts INT0 – INT9. The CPU supports 111 different op-codes and references both a 64K program address space and a 64 K data storage space.

5.1 RAM

The internal data RAM in W78E858 is 768 bytes. It is divided into two banks: 256 bytes of data RAM and 512 bytes of auxiliary RAM. These RAM are addressed by different ways.

- RAM 00H – 7FH can be addressed directly and indirectly as the same as in 80C51. Address pointers are R0 and R1 of the selected register bank.
- RAM 80H – FFH can only be addressed indirectly as the same as in 80C51. Address pointers are R0, R1 of the selected registers bank.
- Auxiliary RAM 0000H – 01FFH is addressed indirectly as the same way to access external data memory with the MOVX instruction. Address pointers are R0 and R1 of the selected register bank and DPTR register. By setting ENAUXRAM flag in CHPCON register bit4 to enable on-chip auxiliary RAM 512 bytes. When the auxiliary RAM is enabled, the data and address will not appear on P0 and P2, they will keep their previous status that before the MOVX instruction be executed. Write the page select 00H or 01H to MXPSR register if R0 and R1 are used as address pointer. When the address of external data memory locations higher than 01FFH or disable auxiliary RAM 512 bytes micro-controller will be performed with the MOVX instruction in the same way as in the 80C51. The auxiliary RAM 512 bytes default is disabled after chip reset.

5.2 EEPROM

The 128 bytes EEPROM is defined in external data memory space that located in FF80H-FFFFH in standard 8-bit series. It is accessed the same as auxiliary RAM512 bytes, the ENEEPROM flag in CHPCON register bit5 is set. Write the page select 02H to MXPSR register, R0 and R1are used as address pointer. The EEPROM provided byte write, page write mode and software write protection is used to protect the data lose when power on or noise. They are described as below:

5.2.1 Byte Write Mode

Once a byte write has been started, it will automatically time itself to completion. A BUSY signal (MXPSR.7) will be used to detect the end of write operation.

5.2.2 Page Write Mode

The EEPROM is divided into 2 pages and each page contains 64 bytes. The page write allows one to 64 bytes of data to be written into the memory during a single internal programming cycle. Page write is initiated in the same manner as byte write mode. After the first byte is written, it can then be followed by one to 63 additional bytes. If a second byte is written within a byte-load cycle time (TBLC) of 150us, the EEPROM will stay at page load cycle. Additional bytes can then be loaded consecutively. The page load cycle will be terminated and the internal programming cycle will start if no additional byte is load within 300us from the last byte be loaded. The address bit6 specify the page



address. All bytes that are loaded to the buffer must have the same page address. The data for page write may be loaded in any order, the sequential loading is not required.

5.2.3 Software Protected Data Write

The EEPROM provides a JEDED-approved optional software-protected data write. Once this scheme is enabled, any write operation requires a series of three-byte program commands (with specific data to a specific address) to be performed before the data load operation. The three-byte load command sequence begins the page load cycle, without which the write operation will not activated. This write scheme provides optimal protection against inadvertent write cycles, such as cycles triggered by noise during system power-up or power-down. Once enabled, the software data protection will remain enabled unless the disable commands are issued. To reset the device to unprotected mode, a six-byte command sequence is required.

The address mapping of the external memory is given as following, if ENAUXRAM or ENEEPROM flags in CHPCON is not set, the CPU will access external memory instead of the on-chip memory. The data, address and read/write strobe signal will appear on relative IO port just like standard 80C52.

5.2.4 Command Codes for Software Data Protection Enable/Disable and Software Erase

BYTE SEQUENCE	ENABLE WRITE PROTECT		DISABLE WRITE PROTECT		SOFTWARE ERASE	
	ADDRESS	DATA	ADDRESS	DATA	ADDRESS	DATA
0 Write	FFD5H	AAH	FFD5H	AAH	FFD5H	AAH
1 Write	FFAAH	55H	FFAAH	55H	FFAAH	55H
2 Write	FFD5H	A0H	FFD5H	80H	FFD5H	80H
3 Write	-	-	FFD5H	AAH	FFD5H	AAH
4 Write	-	-	FFAAH	55H	FFAAH	55H
5 Write	-	-	FFD5H	20H	FFD5H	10H

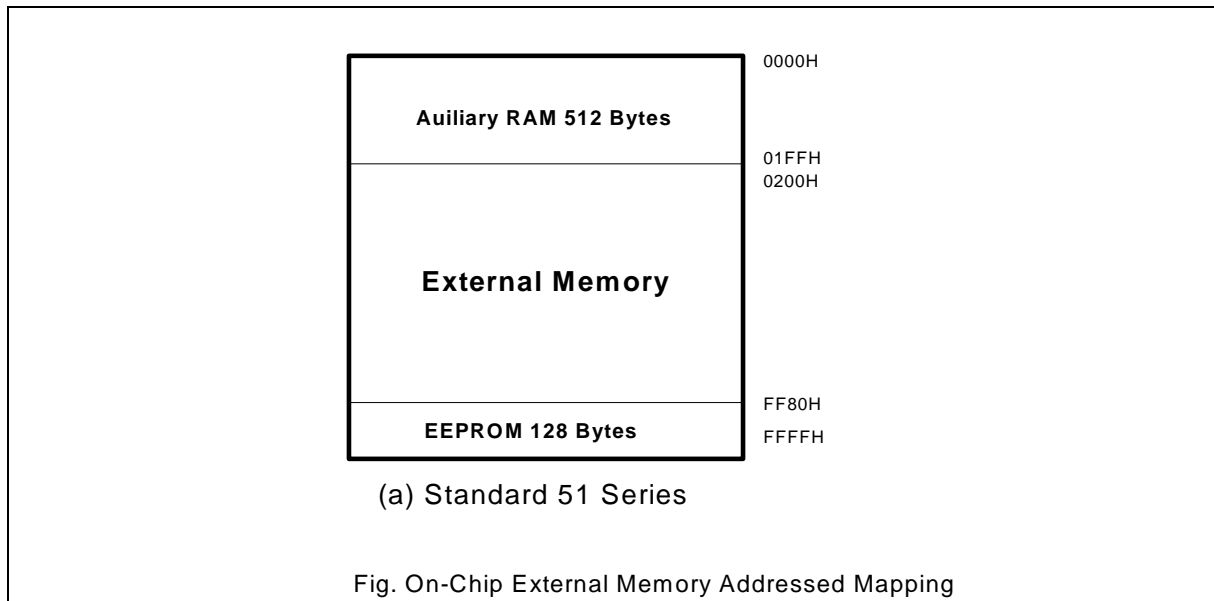



5.3 Demo Code:

```

EEPROM_BASE EQU      FF80H
        org          0000h
        jmp          start

start:
        org          500h

        mov          chpenr,#87h
        mov          chpenr,#59h
        orl          chpcon,#00100000b      ; enable eeprom
        mov          chpenr,#00h
        call         enable_protect
        mov          dptr,#EEPROM_BASE
        mov          r0,#40h                ; only write up to 64
byte/page. Write from FF80h to FFBFh.
        mov          r1,#55h                ; write 55 data.
        call         write_eeprom_block
        call         enable_protect        ; Call it before writing
        mov          dptr,#EEPROM_BASE+40h
        mov          r0,#40h                ; Write from FFC0h to FFFFh
address.
        mov          r1,#55h
        call         write_eeprom_block

        mov          dptr,#EEPROM_BASE
        mov          r0,#80h
        mov          r1,#55h
        call         read_eeprom_block
        jc           $error

        mov          chpenr,#87h
        mov          chpenr,#59h
        anl          chpcon,#11011111b      ; disable eeprom
        mov          chpenr,#00h
        clr          c
        jmp          $end

$error:
        mov          chpenr,#87h
        mov          chpenr,#59h
        anl          chpcon,#11011111b      ; disable eeprom
        mov          chpenr,#00h
        setb         c

$end:
        sjmp        $

;-----
disable_protect:
        mov          dptr,#EEPROM_BASE+55h
        mov          a,#aah
        movx         @dptr,a
        mov          dptr,#EEPROM_BASE+2ah
        mov          a,#55h
        movx         @dptr,a
        mov          dptr,#EEPROM_BASE+55h
        mov          a,#80h
        movx         @dptr,a

```



```

        mov     dptr,#EEPROM_BASE+55h
        mov     a,#aah
        movx   @dptr,a
        mov     dptr,#EEPROM_BASE+2ah
        mov     a,#55h
        movx   @dptr,a
        mov     dptr,#EEPROM_BASE+55h
        mov     a,#20h
        movx   @dptr,a
        call   busy_waiting
        ret

;-----
eeprom_erase:
        mov     dptr,#EEPROM_BASE+55h
        mov     a,#aah
        movx   @dptr,a
        mov     dptr,#EEPROM_BASE+2ah
        mov     a,#55h
        movx   @dptr,a
        mov     dptr,#EEPROM_BASE+55h
        mov     a,#80h
        movx   @dptr,a
        mov     dptr,#EEPROM_BASE+55h
        mov     a,#aah
        movx   @dptr,a
        mov     dptr,#EEPROM_BASE+2ah    ;a5~a0
        mov     a,#55h
        movx   @dptr,a
        mov     dptr,#EEPROM_BASE+55h
        mov     a,#10h
        movx   @dptr,a
        call   busy_waiting
        ret

;-----
enable_protect:
        mov     dptr,#EEPROM_BASE+55h
        mov     a,#aah
        movx   @dptr,a
        mov     dptr,#EEPROM_BASE+2ah
        mov     a,#55h
        movx   @dptr,a
        mov     dptr,#EEPROM_BASE+55h
        mov     a,#a0h
        movx   @dptr,a
        ret

;-----
busy_waiting:
$wait1:
        mov     a,mxpsr
        jnb    acc.7,$wait1

$wait0:
        mov     a,mxpsr
        jb     acc.7,$wait0
        ret

```



```

;-----
write_eeprom_block:
;input r0:counter
;input r1:pattern form
;input dptr:eeprom base address
$write_loop:
        mov     a,r1
        movx   @dptr,a
        inc    dpl
        djnz   r0,$write_loop
        call   busy_waiting
        ret

;-----
read_eeprom_block:
;input r0:counter
;input r1:pattern form
;input dptr:eeprom base address
;output setb c --> fail
        push   b
$read_loop:
        movx   a,@dptr
        mov    b,a
        mov    a,r1
        cjne   a,b,$error
        inc    dpl
        djnz   r0,$read_loop
        clr    c
        jmp    $end
$error:
        setb   c
$end:
        pop    b
        ret
        .end

```

5.4 On-chip Flash EPROM

The W78E858 includes two banks of FLASH EPROM. One is 32K bytes of main FLASH EPROM for application program (APROM) and another 4K bytes of FLASH EPROM for loader program (LDROM) when operating the in-system programming feature. In normal operation, the micro-controller will execute the code from the 32K bytes of APROM. By setting program registers, user can force CPU to switch to the programming mode which will execute the code (loader program) from the 4K bytes of auxiliary LDROM, and this loader program is going to update the contents of the 32K bytes of APROM. After chip reset, the micro-controller executes the new application program in the APROM. This in-system programming feature makes the job easy and efficient in which the application needs to update firmware frequently. In some applications, the in-system programming feature make it possible that end-user is able to easily update the system firmware by themselves without opening the chassis.



5.5 Timers 0, 1, and 2

Timers 0, 1, and 2 each consist of two 8-bit data registers. These are called TL0 and TH0 for Timer 0, TL1 and TH1 for Timer 1, and TL2 and TH2 for Timer 2. The TCON and TMOD registers provide control functions for timers 0, 1. The T2CON register provides control functions for Timer 2. RCAP2H and RCAP2L are used as reload/capture registers for Timer 2.

The operations of Timer 0 and Timer 1 are the same as in the W78C51. Timer 2 is a 16-bit timer/counter that is configured and controlled by the T2CON register. Like Timers 0 and 1, Timer 2 can operate as either an external event counter or as an internal timer, depending on the setting of bit C/T2 in T2CON. Timer 2 has three operating modes: capture, auto-reload, and baud rate generator. The clock speed at capture or auto-reload mode is the same as that of Timers 0 and 1.

5.6 Clock

The W78E858 is designed to use with either a crystal oscillator or an external clock. Internally, the clock is divided by two before it is used by default. This makes the W78E858 relatively insensitive to duty cycle variations in the clock.

5.7 Crystal Oscillator

The W78E858 incorporates a built-in crystal oscillator. To make the oscillator work, a crystal must be connected across pins XTAL1 and XTAL2. In addition, a load capacitor must be connected from each pin to ground, and a resistor must also be connected from XTAL1 to XTAL2 to provide a DC bias when the crystal frequency is above 24 MHz.

5.8 External Clock

An external clock should be connected to pin XTAL1. Pin XTAL2 should be left unconnected. The XTAL1 input is a CMOS-type input, as required by the crystal oscillator. As a result, the external clock signal should have an input one level of greater than 3.5 volts.

5.9 Power Management

5.9.1 Idle Mode

The CPU will enter to idle by setting the IDL bit in the PCON register. In the idle mode, the internal clock to the processor is stopped. The peripherals and the interrupt logic continue to be clocked. The processor will exit idle mode when either an interrupt or a reset occurs.

5.9.2 Power-down Mode

When the PD bit of the PCON register is set, the processor enters the power-down mode. In this mode all of the clocks, including the oscillator are stopped. There are two ways to exit power-down mode, one is by a chip reset and another is via external interrupts wake up if the related control flags are enabled.



5.9.3 Wake-up Via External Interrupts INT0 to INT9

If the external interrupts INT0 to INT9 are enabled, the W78E858 can be awakened from power down mode with the external interrupts if the EA flag in IE register and related interrupt enable is set before enter power down mode. To ensure that the oscillator is stable before the controller starts, the internal clock will remain inactive for some oscillator periods. This is controlled by a on-chip delay counter. The delay time is software selectable and the reset default value is 1536 periods. By setting the PS2 – PS0 bits in AUXR register the delay periods is given as below:

PS2	PS1	PS0	DELAY PERIODS	DELAY TIME (20 MHZ)
0	0	0	192	0.0096 mS
0	0	1	384	0.0192 mS
0	1	0	768	0.0384 mS
0	1	1	1536	0.0768 mS
1	0	0	3072	0.1536 mS
1	0	1	6144	0.372 mS
1	1	0	12288	0.6144 mS
1	1	1	24576	1.2288 mS

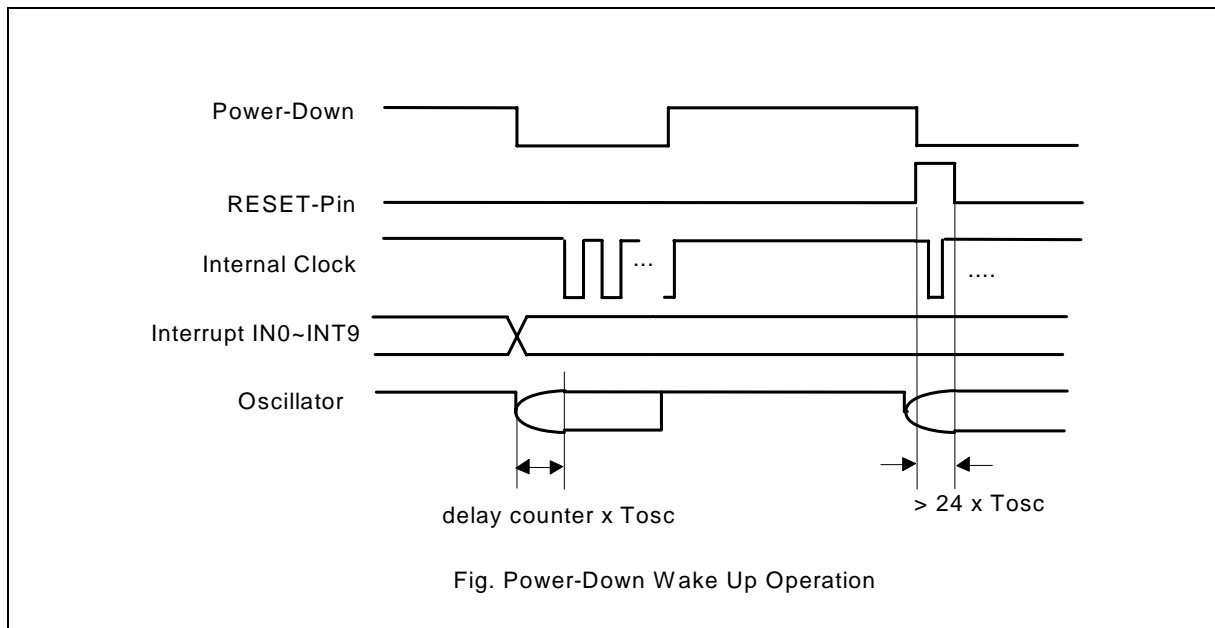

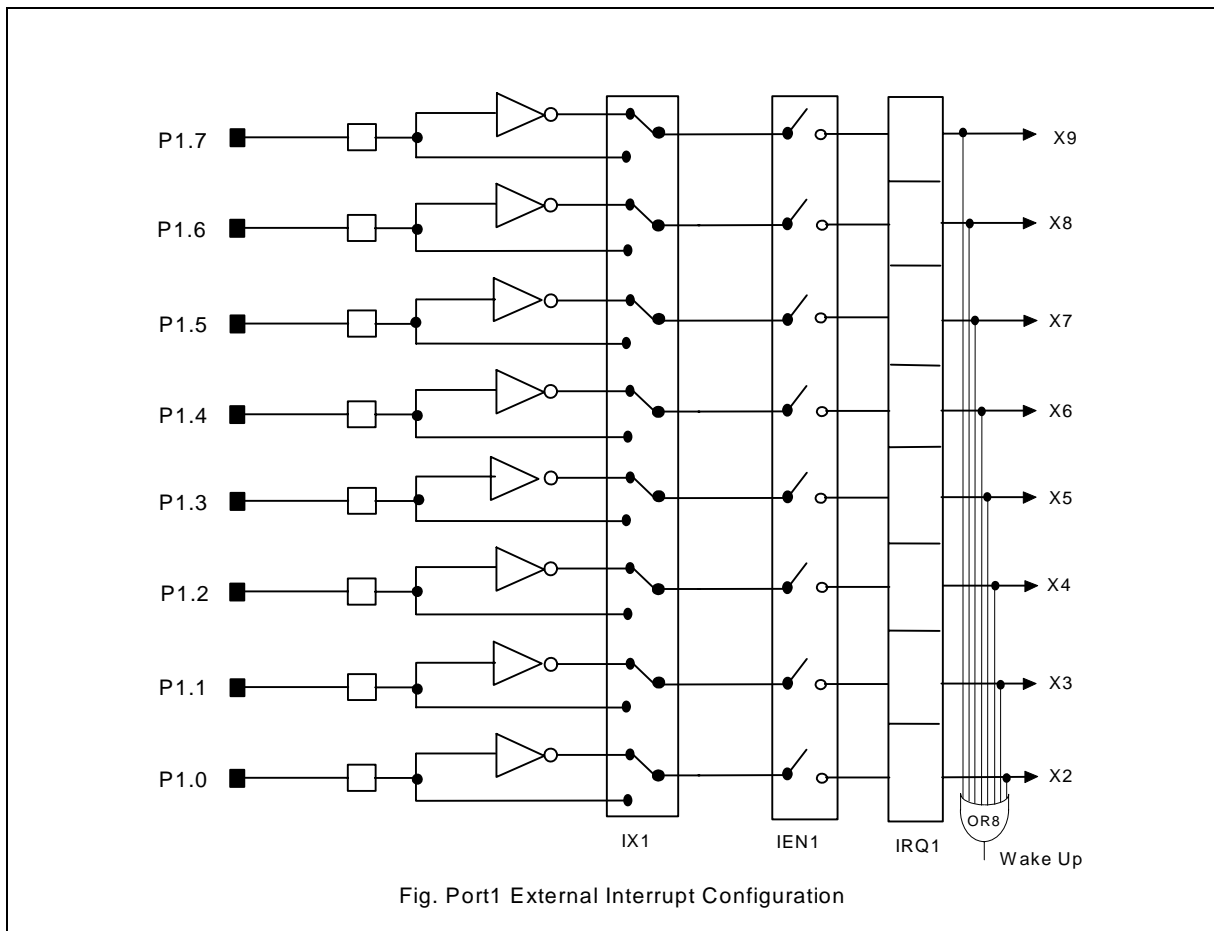

5.10 Reset

The external RST signal is sampled at S5P2. To take effect, it must be held high for at least two machine cycles while the oscillator is running. An internal trigger circuit in the reset line is used to deglitch the reset line when the RA80xx is used with an external RC network. The reset logic also has a special glitch removal circuit that ignores glitches on the reset line. During reset, the ports are initialized to FFH, the stack pointer to 07H, PCON (with the exception of bit 4) to 00H, and all of the other SFR registers except SBUF to 00H. SBUF is not reset.



W78E858 Special Function Registers and Reset Values

F8	+IP1 0000000								FF
F0	+B 00000000						CHPENR 00000000		F7
E8	+IE_1 00000000	IX1 00000000							EF
E0	+ACC 00000000								E7
D8	+P4 11111111								DF
D0	+PSW 00000000								D7
C8	+T2CON 00000000	T2MOD Xxxxx0x	RCAP2L 00000000	RCAP2H 00000000	TL2 00000000	TH2 00000000			CF
C0	+IRQ1 00000000				SFRAL 00000000	SFRAH 00000000	SFRFD 00000000	SFRCN 00000000	C7
B8	+IP 000000							CHPCON 0xx00000	BF
B0	+P3 00000000								B7
A8	+IE 01000000								AF
A0	+P2 11111111		MXPSR 0xxxx00						A7
98	+SCON 00000000	SBUF xxxxxxx							9F
90	+P1 11111111	PWMCON xxx0000	PWMP 00000000	DAC0 00000000	DAC1 00000000	DAC2 00000000	DAC3 00000000		97
88	+TCON 00000000	TMOD 00000000	TL0 00000000	TL1 00000000	TH0 00000000	TH1 00000000	AUXR xxx0110	WDTC 000xx000	8F
80	+P0 11111111	SP 00000111	DPL 00000000	DPH 00000000				PCON 00110000	87

Note: the SFRs marked with a plus sign(+) are both byte and bit-addressable.



5.11 Pulse Width Modulator System

The pulse width modulator system of W78E858 contains four PWM output channels with a common 8-bit counter. These channels generate pulses of programmable length and interval. The prescaler and counter are common to four PWM channels.

5.11.1 PWMCON (91H)

BIT	NAME	FUNCTION
7 – 4	-	Reverse
3	PWM3	Enable P1.7 as PWM clock output.
2	PWM2	Enable P1.6 as PWM clock output.
1	PWM1	Enable P1.5 as PWM clock output.
0	PWM0	Enable P1.4 as PWM clock output.

5.11.2 PWMP (92H)

The prescaler is loaded with the complement of the PWMP register during counter overflow. The repetition frequency is defined by 8-bit prescaler which clocks the counter. The prescaler division factor = (PWMP + 1). Reading the PWMP gives the current reload value. The actual count of the prescaler can't be read.

The PWM counter is enabled with any bit PWMENn (n = 0, 1, 2, 3) of the PWMCON register. Output to the port pin is separately enabled by setting the PWMENn bits in the PWMCON register. The PWM function is reset by a chip reset. In idle mode, the PWM will function as configured in PWMCON. In power-down state of the PWM will freeze when the internal clock stops. If the chip is awakened with an external interrupt, the PWM will continue to function its state when power-down was entered.

The repetition frequency is given by:

$$F_{pwm} = \frac{F_{osc}}{[255 \times (1+PWMP)]}$$

An oscillator frequency of 24 MHz results in a repetition range of 367.65 Hz to 94.12 KHz. The high/low ratio of PWMn is DACn/(255-DACn) for DACn values except 255. A DACn value 255 results in a high PWMn output.

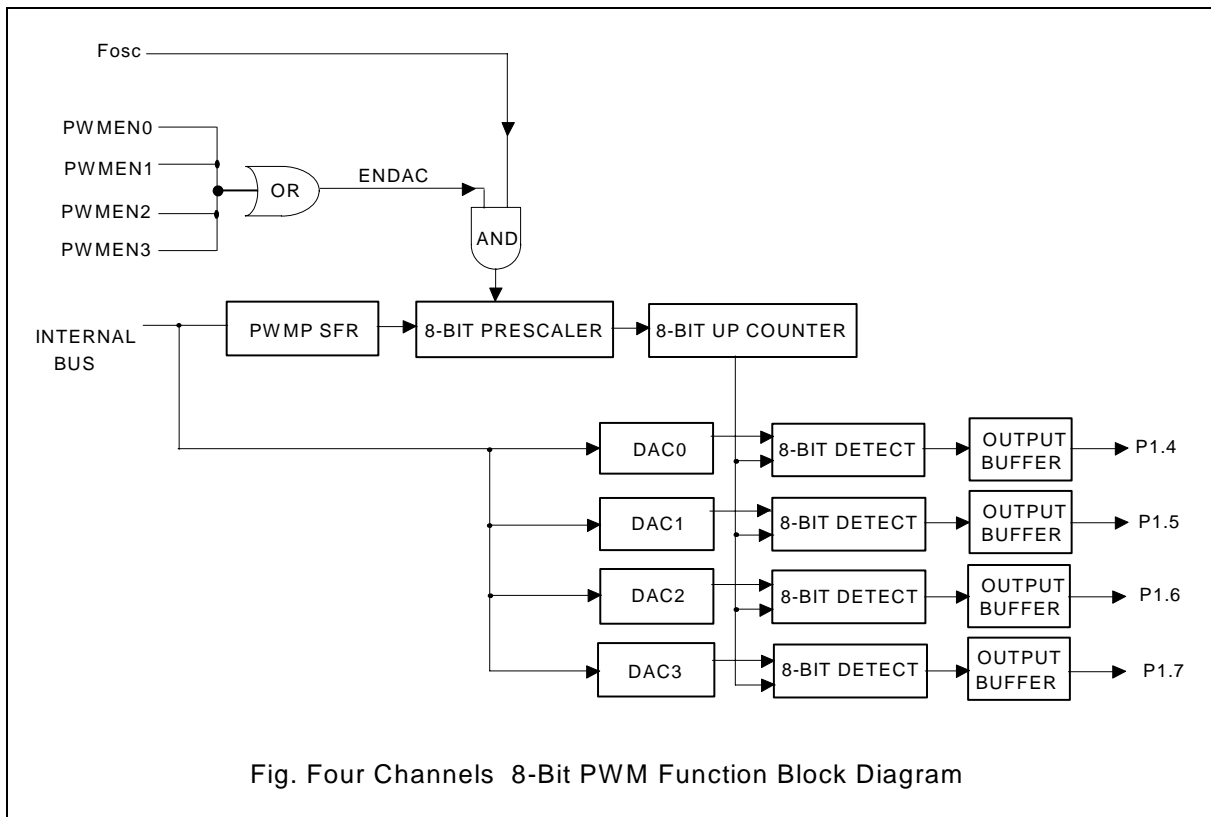

5.12 In-system Programming System

The W78E858 provided in-system programming function for new firmware updated. After the related register and flags are set, user can start timer and force the CPU enter idle mode, then W78E858 will perform the in-system program mode function specify in SFRCN register, the destination data and address will come from the related SFR.

The CHPCON is read only by default. Firmware designer must write 87H, 59H sequentially to this special register CHPENR to enable the CHPCON write attribute, and write other value to disable CHPCON write attribute. This register protects from writing to the CHPCON register carelessly.

5.12.1 SFRAL (C4H)

The programming low-order byte address of FLASH EPROM in-system programming mode

5.12.2 SFRAH (C5H)

The programming high-order byte address of FLASH EPROM in-system programming mode

5.12.3 SFRFD (C6H)

The programming data for on-chip FLASH EPROM in-system programming mode



5.12.4 SFRCN (C7H)

BIT	NAME	FUNCTION
7	-	Reserve.
6	WFWIN	On-chip FLASH EPROM bank select for in-system programming. = 0: 32K bytes FLASH EPROM bank is selected as destination for re-programming. = 1: 4K bytes FLASH EPROM bank is selected as destination for re-programming.
5	OEN	FLASH EPROM output enable.
4	CEN	FLASH EPROM chip enable.
3 – 0	CTRL[3:0]	The flash control signals

5.13 In-system Programming Mode Operating Table

MODE	CTRL<3:0>	WFWIN	OEN	CEN	SFRAL	SFRAH	SFRFD
Erase 32K APROM	0010	0	1	0	X	X	X
Erase 4K LDROM	0010	1	1	0	X	X	X
Program 32K APROM	0001	0	1	0	Address	Address	Data In
Program 4K LDROM	0001	1	1	0	Address	Address	Data In
Read 32K APROM	0000	0	0	0	Address	Address	Data Out
Read 4K LDROM	0000	1	0	0	Address	Address	Data Out



5.13.1 CHPCON (BFH)

BIT	NAME	FUNCTION
7	SWRESET (F04KMODE)	When this bit is set to 1, and both FBOOTSL and FPROGEN are set to 1. It will enforce microcontroller reset to initial condition just like power on reset. This action will re-boot the microcontroller and start to normal operation. To read this bit can determine that the F04KBOOT mode is running.
6	-	Reserve.
5	ENEEPROM	Enable on-chip 128 bytes EEPROM.
4	ENAUXRAM	Enable on-chip 512 bytes auxiliary RAM.
3 – 2	-	-
1	FBOOTSL	The loader program location selection. = 0: loader program in 32K memory bank. = 1: loader program in 4K memory bank.
0	FPROGEN	In system programming enable flag. = 1: enable. The CPU switches to the programming flash mode after entering the idle mode and waken up from interrupt. The CPU will execute the loader program while in on-chip programming mode. = 0: disable. The on-chip FLASH EPROM read-only. In-system programmability is inhibit.

5.14 MXPSR (A2H)

BIT	NAME	FUNCTION
7	BUSY	EEPROM BUSY signal. 1: EEPROM is writing.
6-2	-	Reserved.
1-0	ADDRPNT	Address pointer by MOVX instruction 0: read or write lower 256 byte Auxiliary RAM by pointer of R0 or R1 register 1: read or write Higher 256 byte Auxiliary RAM by pointer of R0 or R1 register 2: 128 byte EEPROM by pointer of R0 or R1 register

5.15 Interrupt System

External events and the real-time-driven on-chip peripherals require service by the CPU asynchronous to do execution of any particular section of code. To tie the asynchronous actives of these functions to normal program execution, a multiple-source, two-priority-level, nested interrupt system is provided. The W78E858 acknowledges interrupt requests from fourteen sources as below:

- INT0 and INT1
- Timer0 and Timer1
- UART serial I/O
- INT2 to INT9 (at Port1)



5.16 External Interrupts INT2 to INT9

Port1 lines serve an alternative purpose at eight additional interrupts INT2 to INT9. When enabled, each of these lines may "wake-up" the device from power-down mode. Using the IX1 register, the each pin may be initialized to either active HIGH or LOW. IRQ1 is the interrupt request flag register. Each flag, if the interrupt is enabled will be set on an interrupt request but must be cleared by software, i.e. via the interrupt software or when the interrupt is disable.

The Port1 interrupts are level sensitive. A Port1 interrupt will be recognized when a level (HIGH or LOW depending on Interrupt Polarity Register IX1) on P1.x is held active for at least one machine cycle. The interrupt request is not served until the next machine cycle.

5.16.1 IE_1 (E8H)

BIT	NAME	FUNCTION
7	EX9	Enable external interrupt 9
6	EX8	Enable external interrupt 8
5	EX7	Enable external interrupt 7
4	EX6	Enable external interrupt 6
3	EX5	Enable external interrupt 5
2	EX4	Enable external interrupt 4
1	EX3	Enable external interrupt 3
0	EX2	Enable external interrupt 2

5.16.2 IP1 (F8H)

BIT	NAME	FUNCTION
7	PX9	External interrupt 9 priority level
6	PX8	External interrupt 8 priority level
5	PX7	External interrupt 7 priority level
4	PX6	External interrupt 6 priority level
3	PX5	External interrupt 5 priority level
2	PX4	External interrupt 4 priority level
1	PX3	External interrupt 3 priority level
0	PX2	External interrupt 2 priority level



5.16.3 IX1 (E9H)

BIT	NAME	FUNCTION
7	IL9	External interrupt 9 polarity level
6	IL8	External interrupt 8 polarity level
5	IL7	External interrupt 7 polarity level
4	IL6	External interrupt 6 polarity level
3	IL5	External interrupt 5 polarity level
2	IL4	External interrupt 4 polarity level
1	IL3	External interrupt 3 polarity level
0	IL2	External interrupt 2 polarity level

5.16.4 IRQ1 (C0H)

BIT	NAME	FUNCTION
7	IQ9	External interrupt 9 request flag
6	IQ8	External interrupt 8 request flag
5	IQ7	External interrupt 7 request flag
4	IQ6	External interrupt 6 request flag
3	IQ5	External interrupt 5 request flag
2	IQ4	External interrupt 4 request flag
1	IQ3	External interrupt 3 request flag
0	IQ2	External interrupt 2 request flag

5.16.5 Interrupt Priority and Vector Address

PRIORITY	INTERRUPT	VECTOR	SOURCE	PRIORITY	INTERRUPT	VECTOR	SOURCE
1	INT0	0003H	External 0	8	TF1	001BH	Timer 1
2	INT5	0053H	External 5	9	SINT	0023H	UART
3	TF0	000BH	Timer 0	10	TF2	002BH	Timer 2
4	INT6	005BH	External 6	11	INT3	0043H	External 3
5	INT1	0013H	External 1	12	INT8	006BH	External 8
6	INT2	003BH	External 2	13	INT4	004BH	External 4
7	INT7	0063H	External 7	14	INT9	0073H	External 9



5.17 F04KBOOT Mode (Boot From 4K Bytes LDROM)

The W78E858 boots from APROM program (32K bytes bank) by default after chip reset. On some occasions, user can force the W78E858 to boot from the LDROM program (4K bank) after chip reset. The setting for this special mode is as follow.

5.17.1 F04KBOOT Mode

RST	P4.3	P2.7	P2.6	MODE
H↓	X	L	L	FO4KBOOT
H↓	L	X	X	FO4KBOOT

Note: In application system design, user must take care the P2, P3, ALE, \overline{EA} and \overline{PSEN} pin status at reset to avoid W78E858 entering the programming mode or F04KBOOT mode in normal operation.

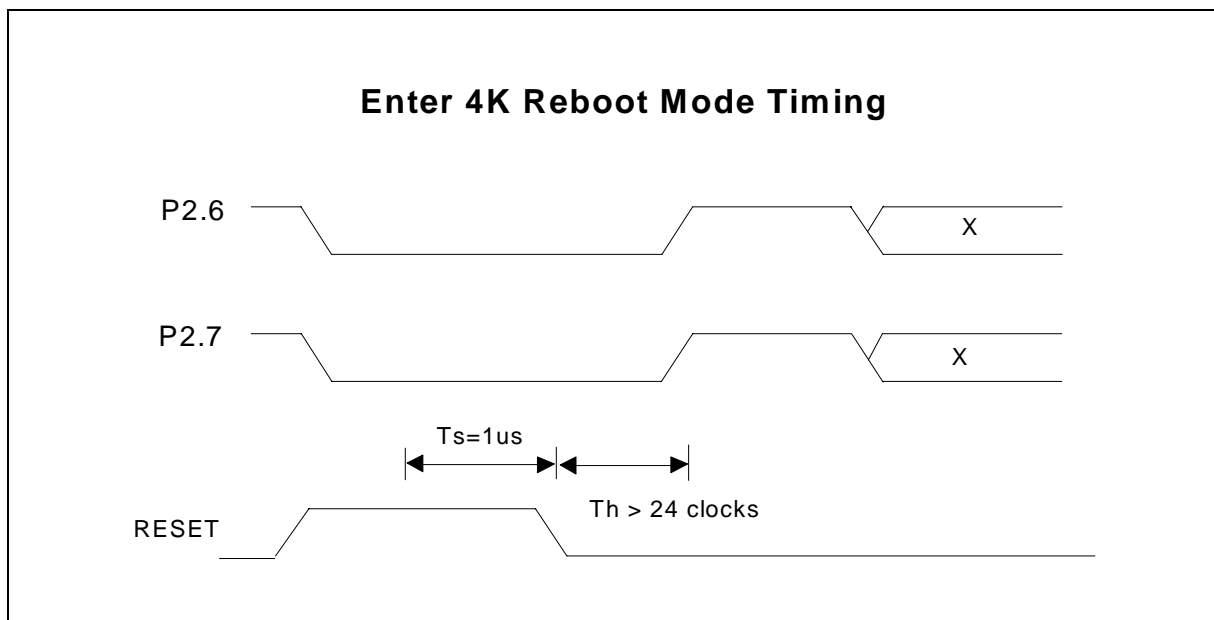

5.18 Security

During the on-chip FLASH EPROM programming mode, the FLASH EPROM can be programmed and verified repeatedly. Until the code inside the FLASH EPROM is confirmed OK, the code can be protected. The protection of FLASH EPROM and those operations on it are described below:

The W78E858 has several special setting registers in FLASH EPROM block. Those bits of the security register can't be changed once they have been programmed from high to low. They can only be reset through erase-all operation. The security register is located at the FFFFH on the same bank with 4K LDROM i.e., P3.6 must set high at writer mode.

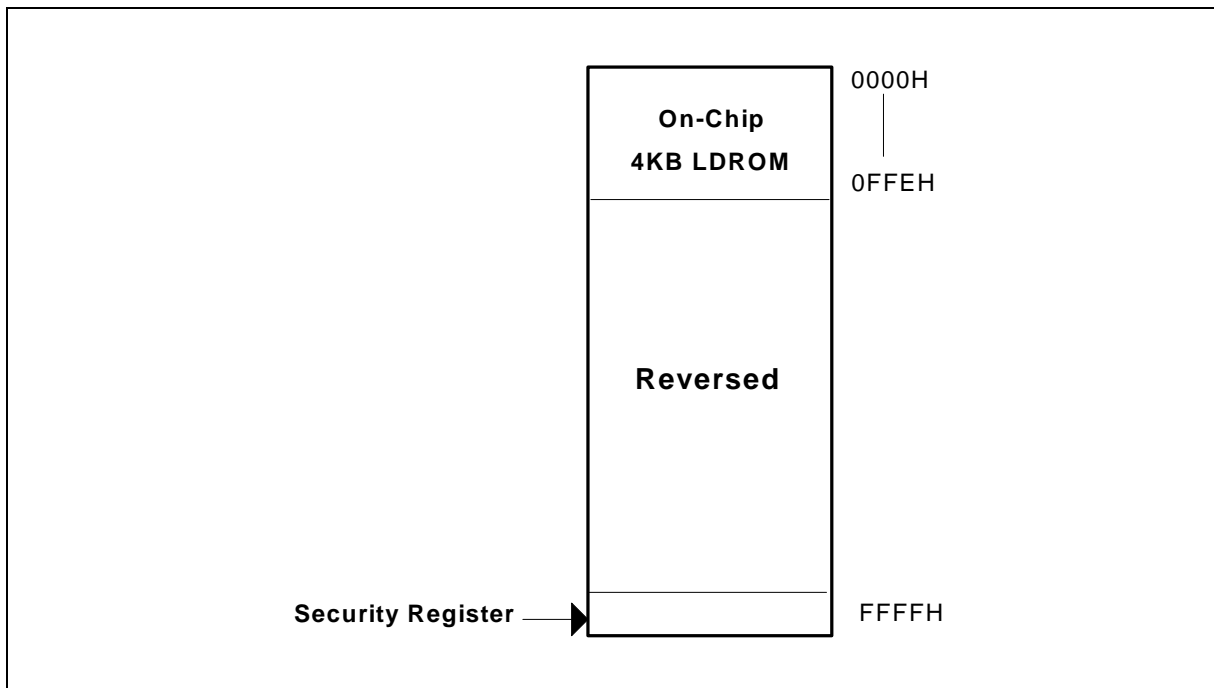

5.18.1 Lock Bit (Bit0)

This bit is used to protect the customer's program code in the W78E858. It may be set after the programmer finishes the programming and verifies sequence. Once these bits are set to logic 0, both the FLASH EPROM data and all data in FLASH EPROM block can't be accessed again.

5.18.2 MOVC Lock (Bit1)

When this bit is program to "0", the MOVC instruction will be disable when the program counter more than 7FFFh or \overline{EA} pin is forced low.

5.18.3 Scramble Enable (Bit2)

This bit is used to protect the customer's program code in the W78E858. If this bit is set to logic 0, the dump ROM code are scrambled by a scramble circuit and the dump ROM code will become a random ROM code.

5.18.4 Oscillator Gain Select (Bit7)

If this bit is set to logic 0 (for 24 MHz), the EMI effect will be reduce. If this bit is set to logic 1 (for 40 MHz), the W78E858 could to use 40 MHz crystal, but the EMI effect is major. So we provide the option bit which could be chose by customer.



5.19 Watch Dog Timer

For more system reliability, W78E858 provides a programmable watch-dog time-out reset function. From programming prescaler select, user can choose a variable prescaler from divided by 2 to divided by 256 to get a suitable time-out period. The time-out period is given by:

$$T_{\text{time-out}} = \frac{1}{F_{\text{osc}}} \times 2^{14} \times \text{PRESCALER} \times 1000 \times 12 \text{ (mS)}$$

(Note: Fosc unit = Hz)

5.19.1 WDTC (8FH)

BIT	NAME	FUNCTION
7	ENW	Enable watch-dog timer if set.
6	CLRW	Clear watch-dog timer and prescaler if set. This flag will be cleared automatically.
5	WIDL	If this bit is set, watch-dog is enabled under idle mode. If cleared, watch-dog is disable under idle mode. Default is cleared.
4 – 3	-	Reversed.
2	PS2	Watch-dog prescaler timer select.
1	PS1	Watch-dog prescaler timer select.
0	PS0	Watch-dog prescaler timer select.

PS2	PS1	PS0	PRESCALER SELCET	WATCH-DOG TIME-OUT PERIOD (Fosc = 20 MHz)
0	0	0	2	19.66 mS
0	1	0	4	39.32 mS
0	0	1	8	78.64 mS
0	1	1	16	157.28 mS
1	0	0	32	314.57 mS
1	0	1	64	629.14 mS
1	1	0	128	1.25 mS
1	1	1	256	2.52 mS



5.20 Programmable Clock-out

A 50% duty cycle clock can be programmed to come out on P1.0. To configure the timer/counter2 as a clock generator, bit C/T2 in T2CON register must be cleared and bit T2OE in T2MOD register must be set. Bit TR2 (T2CON.2) also must be set to start timer. The clock-out frequency depends on the oscillator frequency and reload value of Timer2 capture register (RCAP2H, RCAP2L) as shown in this equation:

$$\frac{\text{oscillator frequency}}{4 \times (65536 - (RCAP2H, RCAP2L))}$$

In the clock-out mode, timer2 roll-overs will not generate an interrupt. This is similar to when it is used as a baud-rate generator. It is possible to use Timer2 as a baud-rate generator and a clock and a clock generator simultaneously.

5.21 Reduce EMI Emission

The transition of ALE will cause noise, so it can be turned off to reduce the EMI emission if it is useless. Turn off the ALE signal transition only need too set the ALEOFF flag in the AUXR register. When ALE is turned off, it will be reactivated when program access external ROM or RAM data or jump to execute external ROM code. After access completely or program returns to internal ROM code, ALE signal will turn off again.

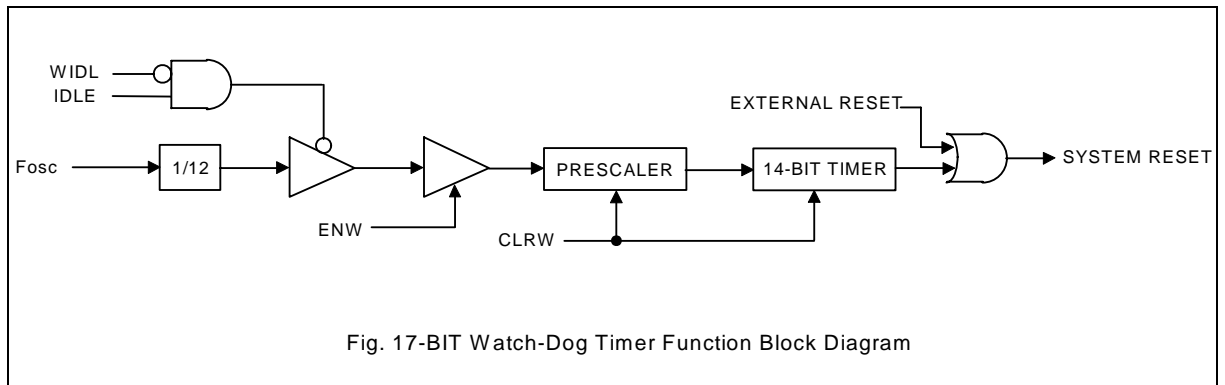

Fig. 17-BIT Watch-Dog Timer Function Block Diagram



6. ELECTRICAL CHARACTERISTICS

6.1 Absolute Maximum Ratings

PARAMETER	SYMBOL	MIN.	MAX.	UNIT
DC Power Supply	VDD – VSS	-0.3	+6.0	V
Input Voltage	Vin	VSS -0.3	VDD +0.3	V
Operating Temperature	Ta	0	70	°C
Storage Temperature	Tst	-55	+150	°C

Note: Exposure to conditions beyond those listed under Absolute Maximum Ratings may adversely affect the life and reliability of the device.

6.2 D.C. Characteristics

(VDD – VSS = 5V ±10%, TA = 25° C, Fosc = 20 MHz, unless otherwise specified.)

PARAMETER	SYM.	SPECIFICATION			TEST CONDITIONS
		MIN.	MAX.	UNIT	
Operating Voltage	VDD	4.5	5.5	V	RST = 1, P0 = VDD
Operating Current	IDD	-	20	mA	No load VDD = 5.5V
Idle Current	IIDLE	-	6	mA	Idle mode VDD = 5.5V
Power Down Current	IPWDN	-	50	μA	Power-down mode VDD = 5.5V
Input Current P1, P2, P3, P4	IIN1	-50	+10	μA	VDD = 5.5V VIN = 0V or VDD
Input Current RST	IIN2	-10	+300	μA	VDD = 5.5V 0 < VIN < VDD
Input Leakage Current P0, \overline{EA}	ILK	-10	+10	μA	VDD = 5.5V 0 < VIN < VDD
Logic 1 to 0 Transition Current P1, P2, P3, P4	ITL[*4]	-500	-	μA	VDD = 5.5V VIN = 2.0V
Input Low Voltage P0, P1, P2, P3, P4, \overline{EA}	VIL1	0	0.8	V	VDD = 4.5V
Input Low Voltage RST	VIL2	0	0.8	V	VDD = 4.5V
Input Low Voltage XTAL1[*4]	VIL3	0	0.8	V	VDD = 4.5V



D.C. Characteristics, continued

PARAMETER	SYM.	SPECIFICATION			TEST CONDITIONS
		MIN.	MAX.	UNIT	
Input High Voltage P0, P1, P2, P3, P4, \overline{EA}	V _{IH1}	2.4	V _{DD} +0.2	V	V _{DD} = 5.5V
Input High Voltage RST	V _{IH2}	3.5	V _{DD} +0.2	V	V _{DD} = 5.5V
Input High Voltage XTAL1 ^[*4]	V _{IH3}	3.5	V _{DD} +0.2	V	V _{DD} = 5.5V
Output Low Voltage P1, P2, P3, P4	V _{OL1}	-	0.45	V	V _{DD} = 4.5V I _{OL} = +2 mA
Output Low Voltage P0, ALE, \overline{PSEN} ^[*3]	V _{OL2}	-	0.45	V	V _{DD} = 4.5V I _{OL} = +4 mA
Sink Current P1, P3, P4	I _{SK1}	4	12	mA	V _{DD} = 4.5V V _{IN} = 0.45V
Sink Current P0, P2, ALE, \overline{PSEN}	I _{SK2}	10	20	mA	V _{DD} = 4.5V V _{IN} = 0.45V
Output High Voltage P1, P2, P3, P4	V _{OH1}	2.4	-	V	V _{DD} = 4.5V I _{OH} = -100 μ A
Output High Voltage P0, ALE, \overline{PSEN} ^[*3]	V _{OH2}	2.4	-	V	V _{DD} = 4.5V I _{OH} = -400 μ A
Source Current P1, P2, P3, P4	I _{SR1}	-120	-250	μ A	V _{DD} = 4.5V V _{IN} = 2.4V (latch)
Source Current P0, P2, ALE, \overline{PSEN}	I _{SR2}	-8	-20	mA	V _{DD} = 4.5V V _{IN} = 2.4V

Notes:

*1. RST pin is a Schmitt trigger input.

*3. P0, ALE and \overline{PSEN} are tested in the external access mode.

*4. XTAL1 is a CMOS input.

*5. Pins of P1, P2, P3, P4 can source a transition current when they are being externally driven from 1 to 0. The transition current reaches its maximum value when V_{IN} approximates to 2V.



6.3 A.C. Characteristics

The AC specifications are a function of the particular process used to manufacture the part, the ratings of the I/O buffers, the capacitive load, and the internal routing capacitance. Most of the specifications can be expressed in terms of multiple input clock periods (TCP), and actual parts will usually experience less than a ± 20 nS variation. The numbers below represent the performance expected from a 0.6 micron CMOS process when using 2 and 4 mA output buffers.

6.3.1 Clock Input Waveform

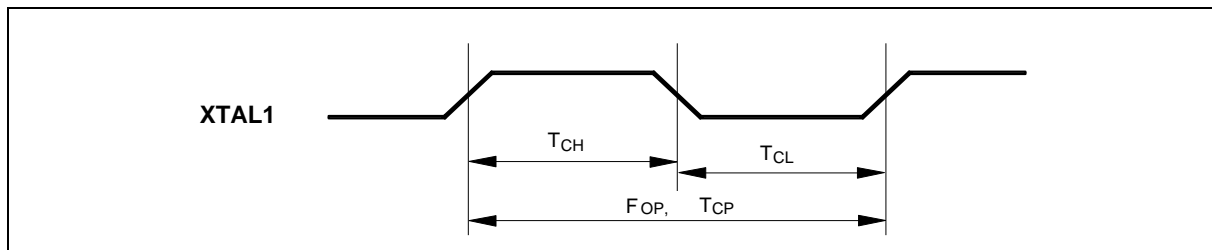

PARAMETER	SYMBOL	MIN.	TYP.	MAX.	UNIT	NOTES
Operating Speed	FOP	0	-	40	MHz	1
Clock Period	TCP	25	-	-	nS	2
Clock High	TCH	10	-	-	nS	3
Clock Low	TCL	10	-	-	nS	3

Notes:

1. The clock may be stopped indefinitely in either state.
2. The TCP specification is used as a reference in other specifications.
3. There are no duty cycle requirements on the XTAL1 input.

6.3.2 Program Fetch Cycle

PARAMETER	SYMBOL	MIN.	TYP.	MAX.	UNIT	NOTES
Address Valid to ALE Low	TAAS	1 TCP- Δ	-	-	nS	4
Address Hold from ALE Low	TAAH	1 TCP- Δ	-	-	nS	1, 4
ALE Low to \overline{PSEN} Low	TAPL	1 TCP- Δ	-	-	nS	4
\overline{PSEN} Low to Data Valid	TPDA	-	-	2 TCP	nS	2
Data Hold after \overline{PSEN} High	TPDH	0	-	1 TCP	nS	3
Data Float after \overline{PSEN} High	TPDZ	0	-	1 TCP	nS	
ALE Pulse Width	TALW	2 TCP- Δ	2 TCP	-	nS	4
\overline{PSEN} Pulse Width	TPSW	3 TCP- Δ	3 TCP	-	nS	4

Notes:

1. P0.0 – P0.7, P2.0 – P2.7 remain stable throughout entire memory cycle.
2. Memory access time is 3 TCP.
3. Data have been latched internally prior to \overline{PSEN} going high.
4. " Δ " (due to buffer driving delay and wire loading) is 20 nS.



6.3.3 Data Read Cycle

PARAMETER	SYMBOL	MIN.	TYP.	MAX.	UNIT	NOTES
ALE Low to \overline{RD} Low	Tdar	3 TCP- Δ	-	3 TCP+ Δ	nS	1, 2
\overline{RD} Low to Data Valid	Tdda	-	-	4 TCP	nS	1
Data Hold from \overline{RD} High	Tddh	0	-	2 TCP	nS	
Data Float from \overline{RD} High	Tddz	0	-	2 TCP	nS	
\overline{RD} Pulse Width	Tdrd	6 TCP- Δ	6 TCP	-	nS	2

Notes:

1. Data memory access time is 8 TCP.
2. " Δ " (due to buffer driving delay and wire loading) is 20 nS.

6.3.4 Data Write Cycle

PARAMETER	SYMBOL	MIN.	TYP.	MAX.	UNIT
ALE Low to \overline{WR} Low	TDAW	3 TCP- Δ	-	3 TCP+ Δ	nS
Data Valid to \overline{WR} Low	TDAD	1 TCP- Δ	-	-	nS
Data Hold from \overline{WR} High	TDWD	1 TCP- Δ	-	-	nS
\overline{WR} Pulse Width	TDWR	6 TCP- Δ	6 TCP	-	nS

Note: " Δ " (due to buffer driving delay and wire loading) is 20 nS.

6.3.5 Port Access Cycle

PARAMETER	SYMBOL	MIN.	TYP.	MAX.	UNIT
Port Input Setup to ALE Low	TPDS	1 TCP	-	-	nS
Port Input Hold from ALE Low	TPDH	0	-	-	nS
Port Output to ALE	TPDA	1 TCP	-	-	nS

Note: Ports are read during S5P2, and output data becomes available at the end of S6P2. The timing data are referenced to ALE, since it provides a convenient reference.

6.3.6 Flash Mode Timing

PARAMETER	SYMBOL	MIN.	TYP.	MAX.	UNIT	NOTES
Reset Valid	TRV	9	10	11	μ S	-
Enter Flash Mode Reset Low	TEFRL	9	10	11	μ S	-
Program Pulse High	TPPH	18	20	22	μ S	-
Program Pulse Low	TPPL	40	50	60	μ S	-
Erase Pulse Low	TEPL	25	30	50	mS	-
Read Pulse Low	TRPL	1.35	1.5	1.65	μ S	-
Address PreFix	TAPF	45	50	55	nS	-
Data Remain	TDR	81	90	99	nS	-



7. TIMING WAVEFORMS

7.1 Program Fetch Cycle

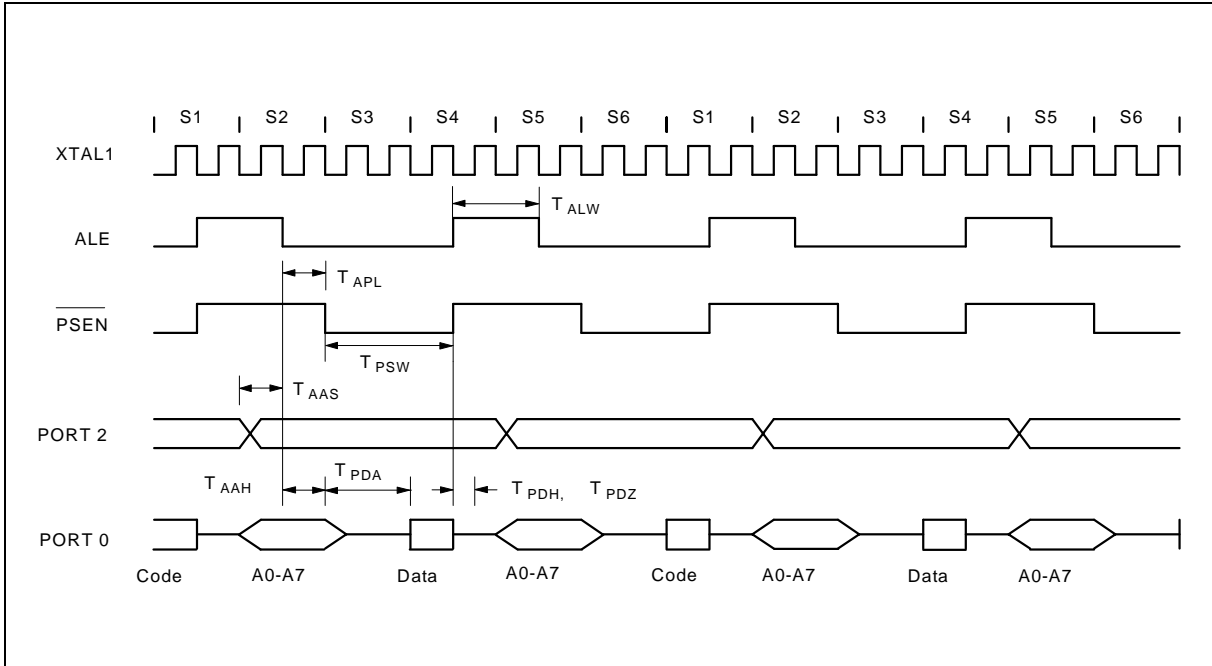

7.2 Data Read Cycle

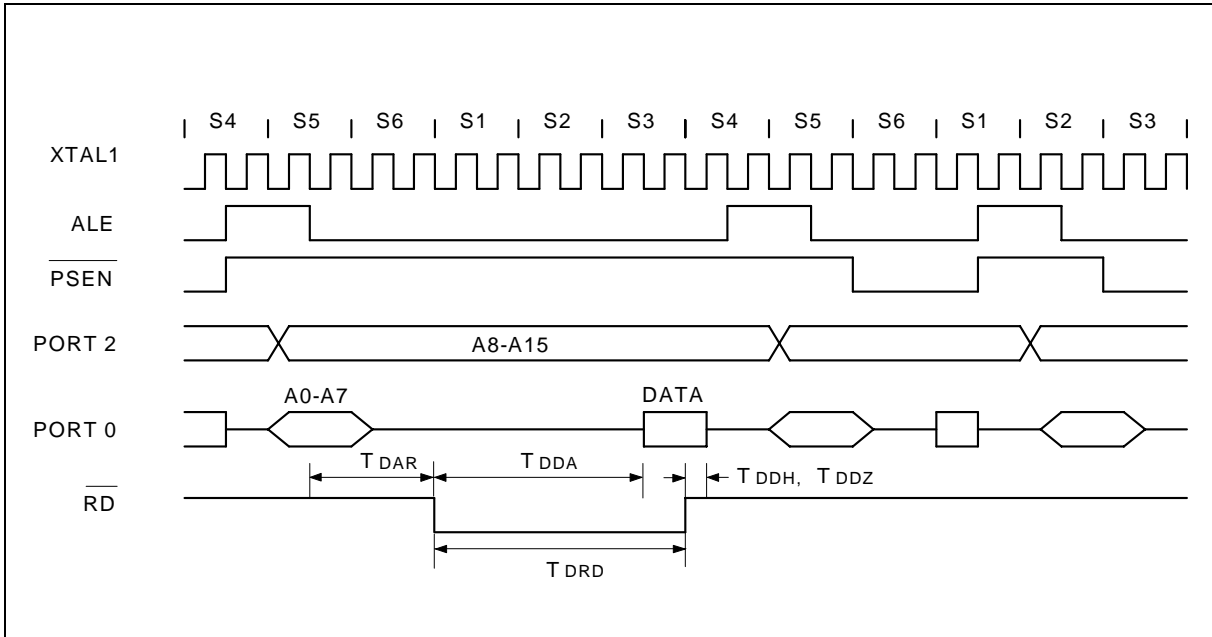



Timing Waveforms, continued

7.3 Data Write Cycle

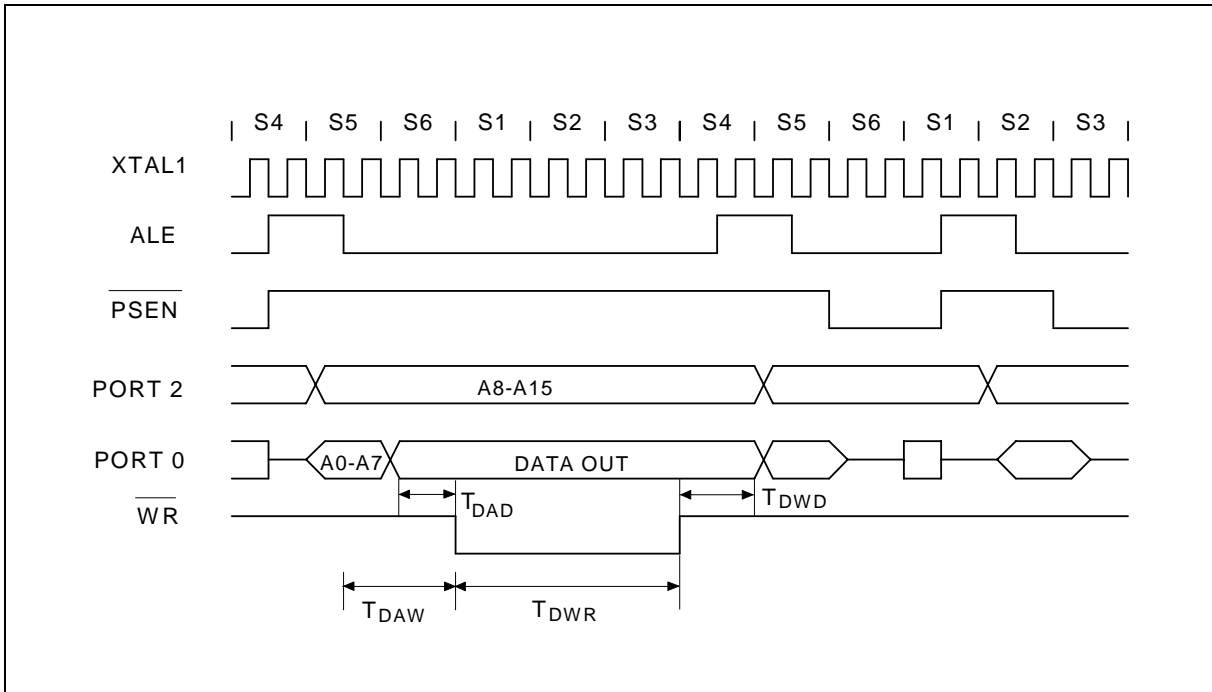

7.4 Port Access Cycle

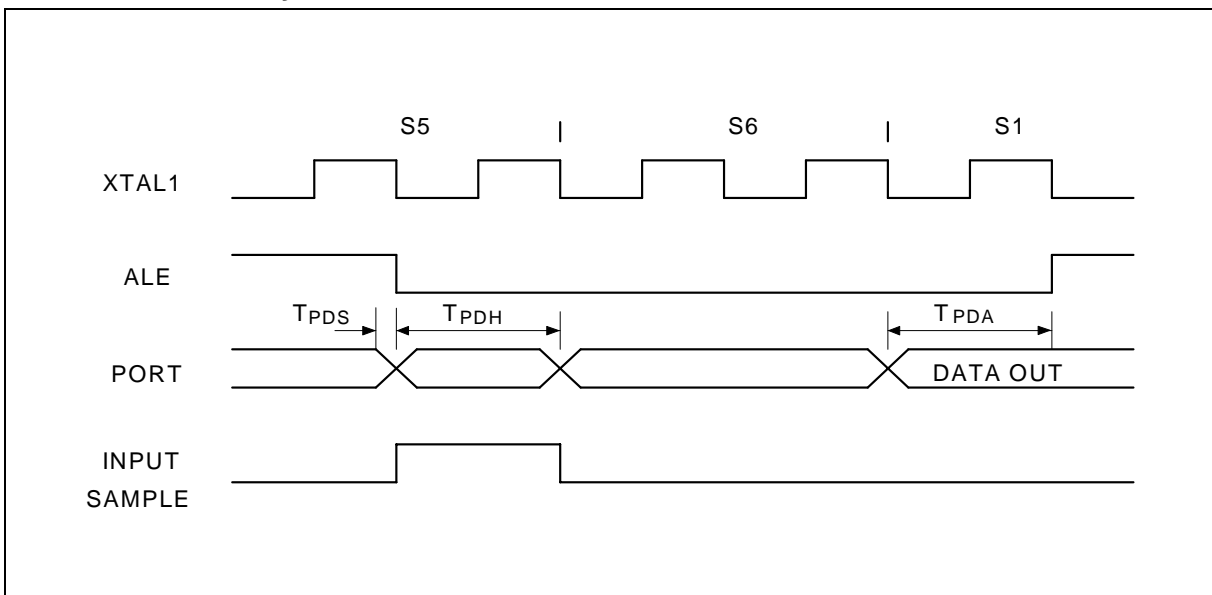



8. TYPICAL APPLICATION CIRCUITS

8.1 Expanded External Program Memory and Crystal

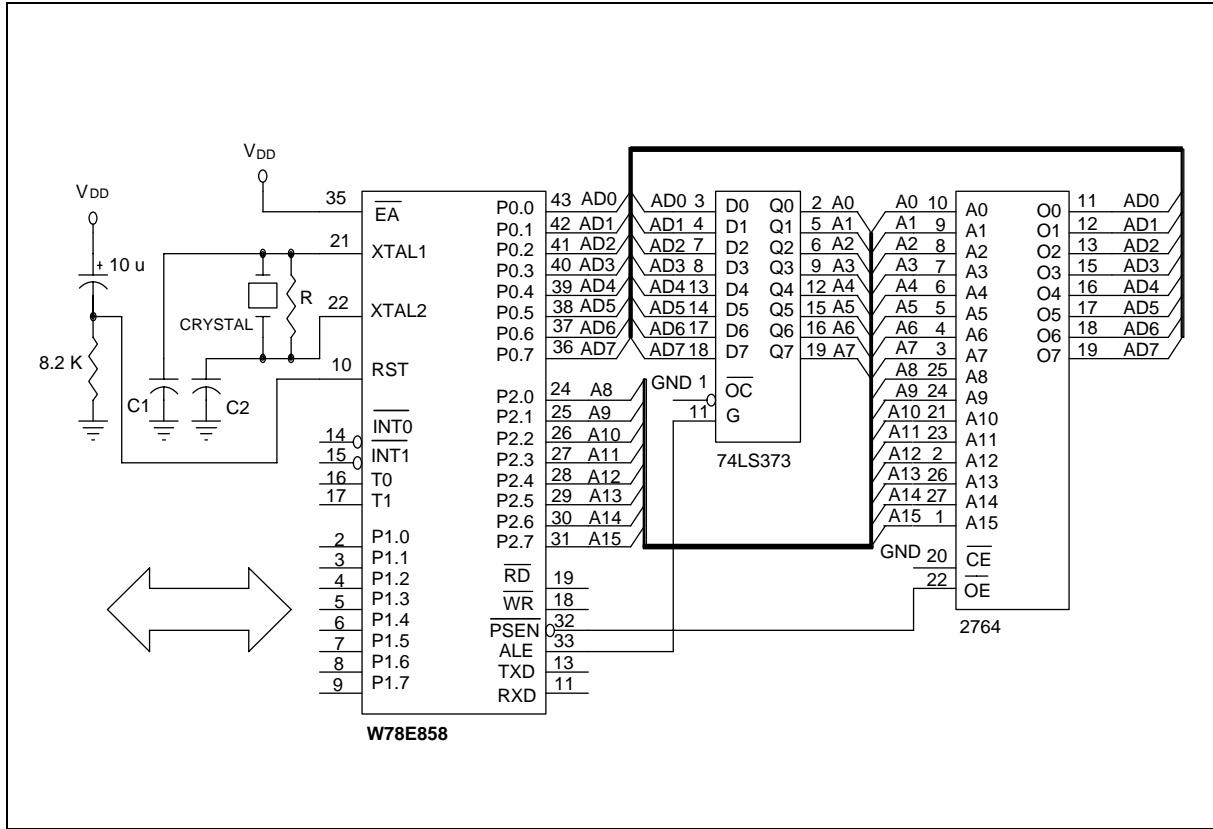

Figure A

CRYSTAL	C1	C2	R
6 MHz	68P – 100P	68P – 100P	6.8K
16 MHz	20P – 100P	20P – 100P	6.8K
24 MHz	10P – 68P	10P – 68P	6.8K
32 MHz	5P – 20P	5P – 20P	6.8K
40 MHz	5P	5P	3.3K

Above table shows the reference values for crystal applications.

Notes:

1. C1, C2, R components refer to Figure A
2. Crystal layout must get close to XTAL1 and XTAL2 pins on user's application board.



Typical Application Circuits, continued

8.2 Expanded External Data Memory and Oscillator

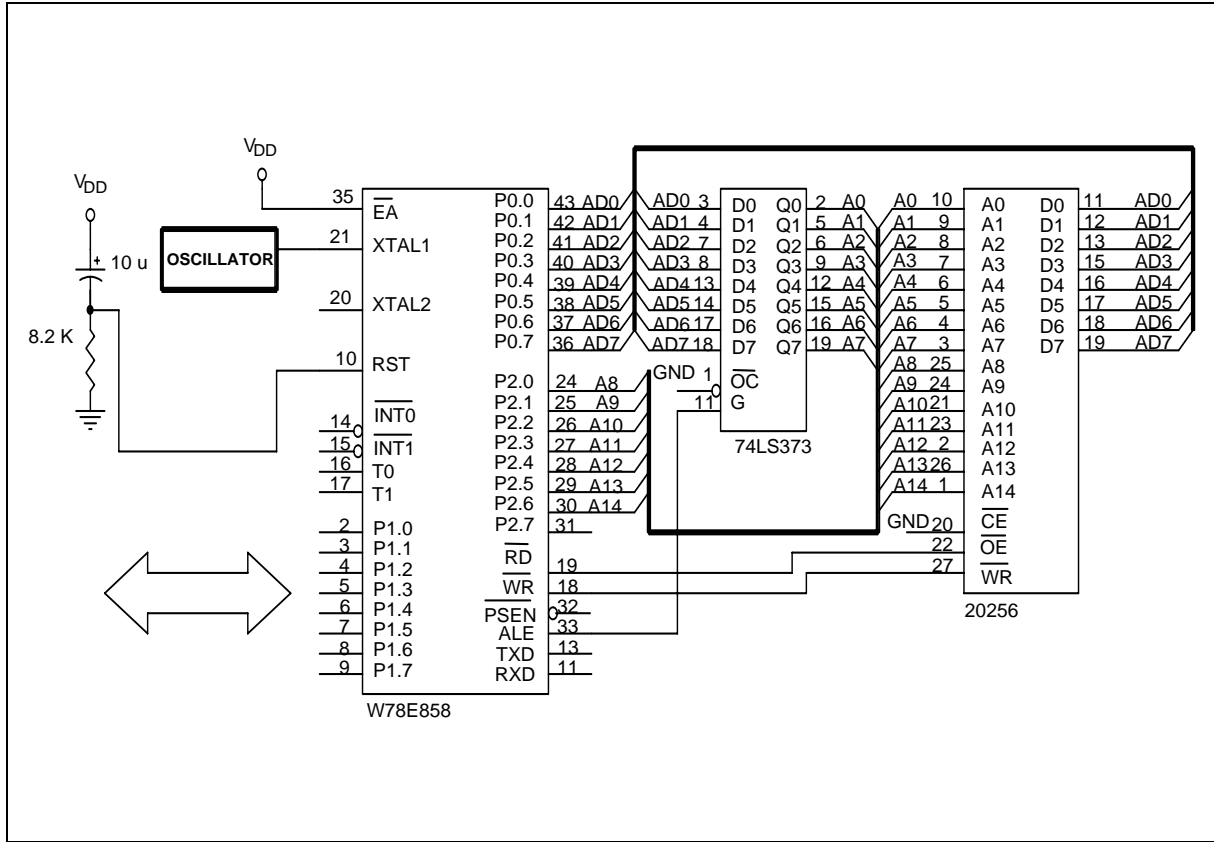
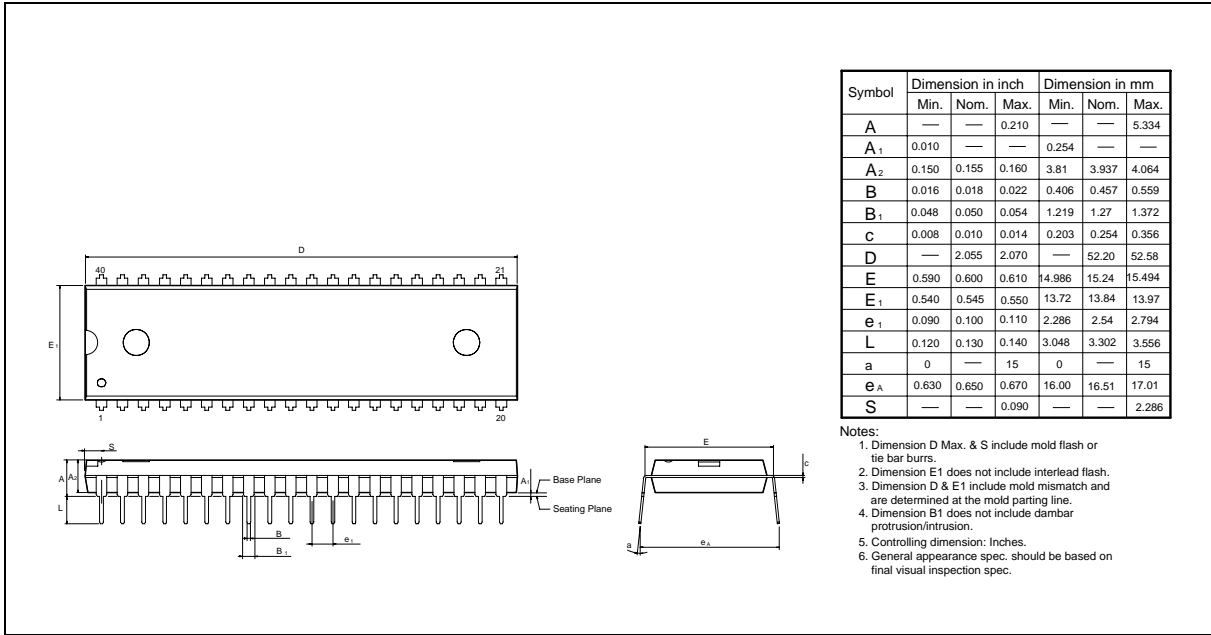

Figure B



9. PACKAGE DIMENSIONS

9.1 40-pin DIP



9.2 44-pin PLCC

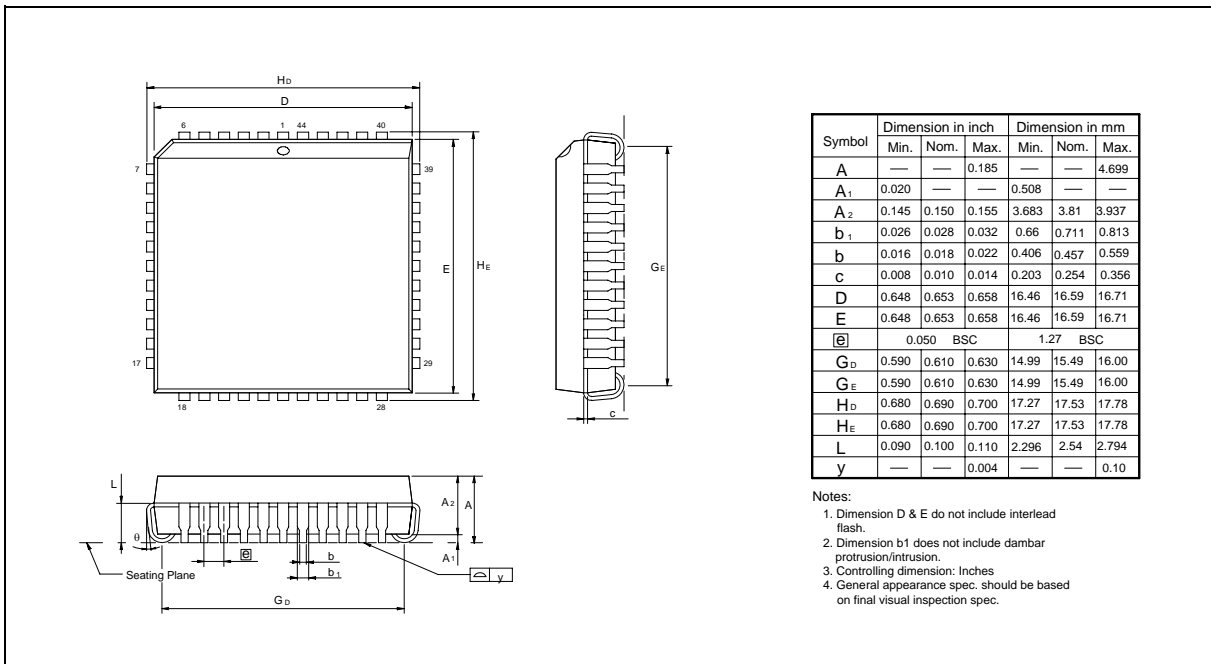



Package Dimensions, continued

9.3 44-pin PQFP

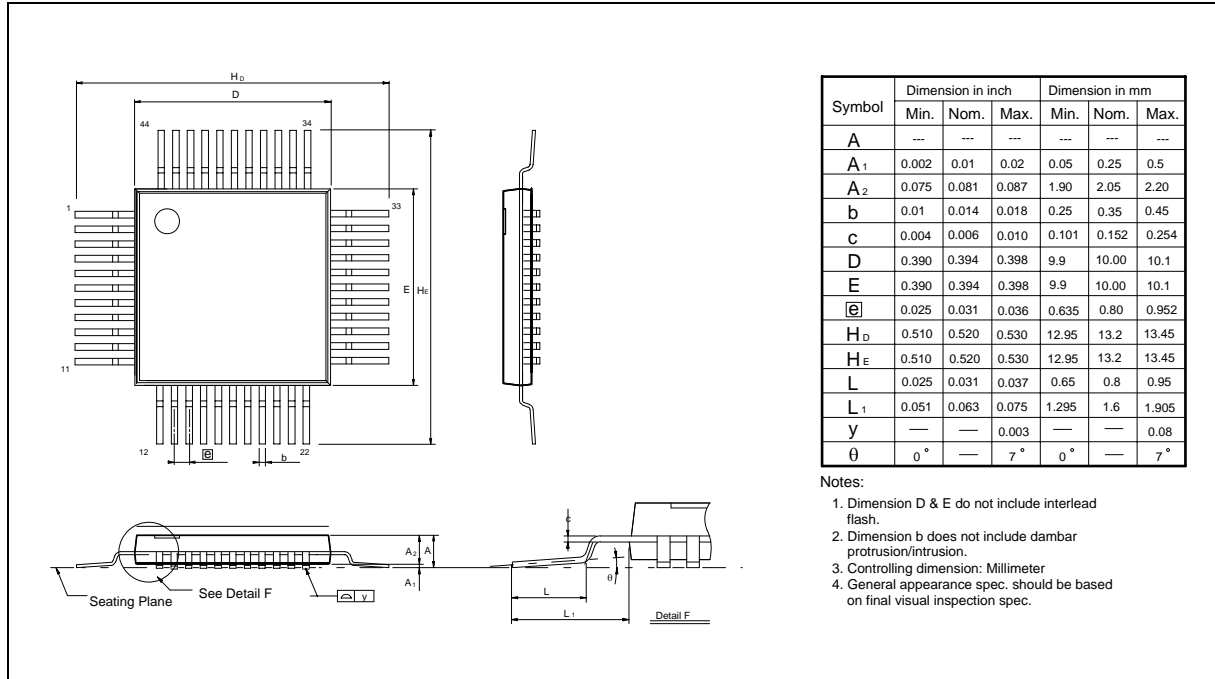

Symbol	Dimension in inch			Dimension in mm		
	Min.	Nom.	Max.	Min.	Nom.	Max.
A	—	—	—	—	—	—
A ₁	0.002	0.01	0.02	0.05	0.25	0.5
A ₂	0.075	0.081	0.087	1.90	2.05	2.20
b	0.01	0.014	0.018	0.25	0.35	0.45
c	0.004	0.006	0.010	0.101	0.152	0.254
D	0.390	0.394	0.398	9.9	10.00	10.1
E	0.390	0.394	0.398	9.9	10.00	10.1
ⓐ	0.025	0.031	0.036	0.635	0.80	0.952
H _D	0.510	0.520	0.530	12.95	13.2	13.45
H _E	0.510	0.520	0.530	12.95	13.2	13.45
L	0.025	0.031	0.037	0.65	0.8	0.95
L ₁	0.051	0.063	0.075	1.295	1.6	1.905
y	—	—	0.003	—	—	0.08
θ	0°	—	7°	0°	—	7°

- Notes:
1. Dimension D & E do not include interlead flash.
 2. Dimension b does not include dambar protrusion/intrusion.
 3. Controlling dimension: Millimeter
 4. General appearance spec. should be based on final visual inspection spec.



10. VERSION HISTORY

VERSION	DATE	PAGE	DESCRIPTION
A	Oct. 2001	-	Initial Issued
B	Jul. 2002	15	Modify timer 2 interrupt vector address
C	Nov. 2002	5	EEPROM address of command code
D	May. 2004	6	Remove erase acquisition flow
		6	Add a demo code
A5	April 20, 2005	33	Add Important Notice
A6	May 3, 2006	7	Revise "03H to MXPSR" to "02H to MXPSR"
A7	November 6, 2006		Remove block diagram

Important Notice

Winbond products are not designed, intended, authorized or warranted for use as components in systems or equipment intended for surgical implantation, atomic energy control instruments, airplane or spaceship instruments, transportation instruments, traffic signal instruments, combustion control instruments, or for other applications intended to support or sustain life. Further more, Winbond products are not intended for applications wherein failure of Winbond products could result or lead to a situation wherein personal injury, death or severe property or environmental damage could occur.

Winbond customers using or selling these products for use in such applications do so at their own risk and agree to fully indemnify Winbond for any damages resulting from such improper use or sales.

Please note that all data and specifications are subject to change without notice.
All the trademarks of products and companies mentioned in this datasheet belong to their respective owners.

Publication Release Date: November 6, 2006