



**PRODUCT SELECTION GUIDE**

**Product Summary:**

Output Wave Form: Clipped Sine Wave					
TCXO	VCTCXO	Available Frequency Range	RoHS Compliant Equivalent Model		Package Description
<b>Thru-Hole Types</b>					
<b>M38U</b>	<b>VM38U</b>	10 ~ 30 MHz	<b>M38GU</b>	<b>VM38GU</b>	4 pin DIP
<b>M39U</b>	<b>VM39U</b>	10 ~ 30 MHz	<b>M39GU</b>	<b>VM39GU</b>	4 pin DIP
<b>M14U</b>	<b>VM14U</b>	10 ~ 30 MHz	<b>M14GU</b>	<b>VM14GU</b>	4 pin DIP. Hermetically sealed.
<b>M15U</b>	<b>VM15U</b>	10 ~ 30 MHz	<b>M15GU</b>	<b>VM15GU</b>	4 pin DIP. With trimmer
<b>M8U</b>	<b>VM8U</b>	10 ~ 30 MHz	<b>M8GU</b>	<b>VM8GU</b>	4 pin DIP. Half size. Hermetically sealed.
<b>M9U</b>	<b>VM9U</b>	10 ~ 30 MHz	<b>M9GU</b>	<b>VM9GU</b>	4 pin DIP. Half size. With trimmer
<b>Gull Wing Surface Mount Types</b>					
<b>M47U</b>	<b>VM47U</b>	10 ~ 30 MHz	<b>M47GU</b>	<b>VM47GU</b>	4 pin gull wing
<b>M24U</b>	<b>VM24U</b>	10 ~ 30 MHz	<b>M24GU</b>	<b>VM24GU</b>	4 pin gull wing. Hermetically sealed.
<b>M25U</b>	<b>VM25U</b>	10 ~ 30 MHz	<b>M25GU</b>	<b>VM25GU</b>	4 pin gull wing. With trimmer
<b>M28U</b>	<b>VM28U</b>	10 ~ 30 MHz	<b>M28GU</b>	<b>VM28GU</b>	4 pin gull wing. Half size. Hermetically sealed.
<b>M29U</b>	<b>VM29U</b>	10 ~ 30 MHz	<b>M29GU</b>	<b>VM29GU</b>	4 pin Gull wing. Half size. With trimmer
<b>Leadless Surface Mount Types</b>					
<b>M62U</b>	<b>VM62U</b>	10 ~ 30 MHz	<b>M62GU</b>	<b>VM62GU</b>	6 pad FR4 substrate. 2.5 mm H
<b>M42U</b>	<b>VM42U</b>	10 ~ 30 MHz	<b>M42GU</b>	<b>VM42GU</b>	4 pad FR4 substrate. 2.5mm H
<b>M64U</b>	<b>VM64U</b>	10 ~ 30 MHz	<b>M64GU</b>	<b>VM64GU</b>	6 pad FR4 substrate. 4.7 mm H
<b>M44U</b>	<b>VM44U</b>	10 ~ 30 MHz	<b>M44GU</b>	<b>VM44GU</b>	4 pad FR4 substrate. 4.7 mm H
<b>M57U</b>	<b>VM57U</b>	10 ~ 30 MHz	<b>Same<sup>(1)</sup></b>	<b>Same<sup>(1)</sup></b>	4 pad ceramic substrate. 5x7 mm
<b>M53U</b>	<b>VM53U</b>	10 ~ 30 MHz	<b>Same<sup>(1)</sup></b>	<b>Same<sup>(1)</sup></b>	4 pad ceramic substrate. 5x3.2 mm

“\_” is voltage code. See table on next page.

For RoHS equivalent model please add “G” after the package code. For example: M14GU3.

<sup>(1)</sup> M57U, VM57U, M53U and VM53U are RoHS compliant and lead free products. .

Note: Frequency tuning by the built-in mechanical trimmer is standard for all models except for M57U, VM57U, M53U and VM53U.

**Product Options**

- No mechanical Trimmer models are available to allow for aqueous washing. For Part number: Please add “1” after the regular model prefix. For example: M381U3.

**MERCURY [www.mercury-crystal.com](http://www.mercury-crystal.com)**

Taiwan: TEL (886)-2-2406-2779, FAX (886)-2-0769, e-mail: [sales-tw@mercury-crystal.com](mailto:sales-tw@mercury-crystal.com)

U.S.A.: TEL (1)-909-466-0427, FAX (1)-909-466-0762, e-mail: [sales-us@mercury-crystal.com](mailto:sales-us@mercury-crystal.com)

<b>“TCXO” and “VCTCXO” “U” Series</b> <b>Wave Form: True Sine Wave 10KΩ // 10 pF load</b>		<b>MERCURY</b> Since 1973
----------------------------------------------------------------------------------------------	-------------------------------------------------------------------------------------	------------------------------

**General Specifications** (at +25°C and specified input voltage)

<b>Frequency Range</b>		10 MHz ~ 30.0 MHz		
<b>Output Wave Form</b>		<b>True Sine</b> wave. Wave form code is “U” Load is 10 KΩ // 10 pF. For 50 ohm load true sine wave output please refer to “E” series		
<b>Initial Calibration Tolerance</b>		Models with mechanical trimmer: < ±1 ppm. +25°C ±2°C. Models without mechanical trimmer: ±2 ppm at +25°C ±2°C.		
<b>Standard Frequencies (partial list)</b>		10.0, 12.8, 13.0, 15.36, 16.384, 19.2, 19.68, 20.0 MHz		
<b>Frequency Stability</b> vs Temperature vs Aging vs Voltage Change vs Load Change vs reflow (SMD models only)		±1 ppm, ±1.5 ppm, ±2.0 ppm, ±2.5 ppm, ±3 ppm, or ±5 ppm, over operating temperature range. Referenced to frequency reading at +25°C. ±1.0 ppm max. first year at +25°C ±0.3 ppm max. for a ±5% input voltage change ±0.3 ppm max. for a ±10% loading condition change ±1 ppm max. 1 reflow and measured 24 hours afterwards		
<b>Typical Operating Temperature Range (examples)</b>		0°C to +60°C    0°C to +70°C    -10°C to +60°C -20°C to +70°C    -30°C to +60°C    -30°C to +75°C -30°C to +85°C    -40°C to +85°C. or custom.		
<b>Output Voltage Level</b>		0.8 Vp-p min. ; 1.0 Vp-p typical		
<b>Current Consumption. (Over operating temperature range.)</b>		2 mA max.		
<b>Mechanical Frequency Tuning</b>		<b>Standard</b>	±3 ppm min. tuning Note: VM57 and VM53 have no mechanical trimmer built-in.	
		<b>Option</b>	No mechanical trimmer built-in (for aqueous washing cycles). Part number: Please add “1” after the regular model prefix. For example: M381U3.	
<b>Input Voltage Range</b>		+2.8V, +3.0V, +3.3V, or +5.0V		
		+3.0 V (voltage code is “3”)	+5.0 V (voltage code is “5”)	
<b>Pin 1 Options</b>	<b>VCTCXO only</b>	<b>Control voltage Range</b>	+1.5 V±1.0 V    +2.5 V±2.0 V.	
		<b>Frequency Range</b>	<b>Standard</b>	±9 ppm min. ±15 ppm max.
			<b>Option</b>	±25 ppm max.
		<b>Slope Polarity</b>	Positive slope. Positive voltage for positive frequency shift.	
<b>Linearity</b>	10 % max.			
<b>Start-Up Time.</b>		2 m. sec. Typical, 3 m. sec. max. (reach 90% amplitude and at +25°C ±2°C)		
<b>Output Load</b>		10 KΩ // 10 pF		
<b>Harmonics Distortion</b>		M57, M53, VM57, VM53: -10 dB typ. -7 dB max. Other models: -12 dB typ. -9 dB max.		
<b>Output Format</b>		DC block, AC coupled		
<b>Phase Noise (VM53S3-20.000)</b>		-115 dBc/Hz at 100 Hz offset; -135 dBc/Hz at 1 KHz offset; -148 dBc/Hz at 10 KHz offset		
<b>Storage Temperature</b>		-40°C to +85°C		

**Note 1:** Some specifications are package dependent. Please refer to the spec. sheet of individual packages once a package is selected..

**Note 2:** TCXO products ordered without mechanical and electrical frequency tuning should have a frequency tolerance of ±2 ppm (at +25°C) and the frequency stability over temperature will be from that measured value.



**Typical Phase Noise** VM53U3-20.000

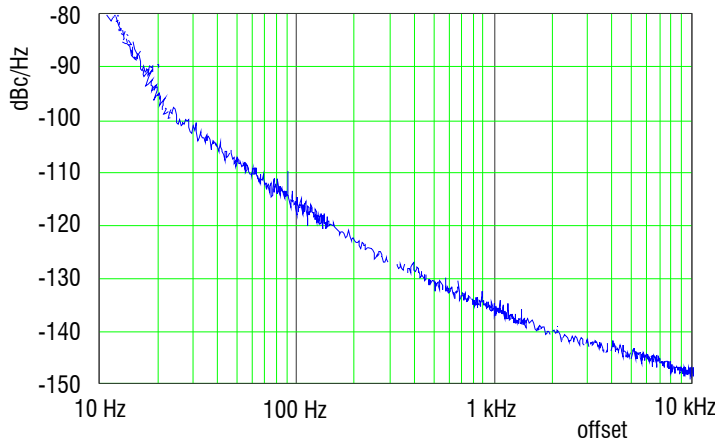

**Part Number Format and Examples:**

**Example of TCXO:** M53U3-20.000-2.5/-30+85;

**Example of VCTCXO:** VM53U3-20.000-2.5/-30+85

										: customer to specify
V	M53	U	3	—	20.000	—	2.5	/	-30+85	
❶	❷	❸	❹		❺		❻		❼	

- ❶: “V” for VCTCXO; “blank” for TCXO
- ❷: Package code
- ❸: Wave form code “U” for true sine wave
- ❹: Supply voltage code: “28” for +2.8V, “3” for +3.0V, “33” for “+3.3V”, “5” for +5.0V
- ❺: Frequency in MHz
- ❻: Frequency stability in ±ppm
- ❼: Operating temperature range in °C

**True Sine Wave TCXO (VCTCXO) Test Circuit (example of VM14):**

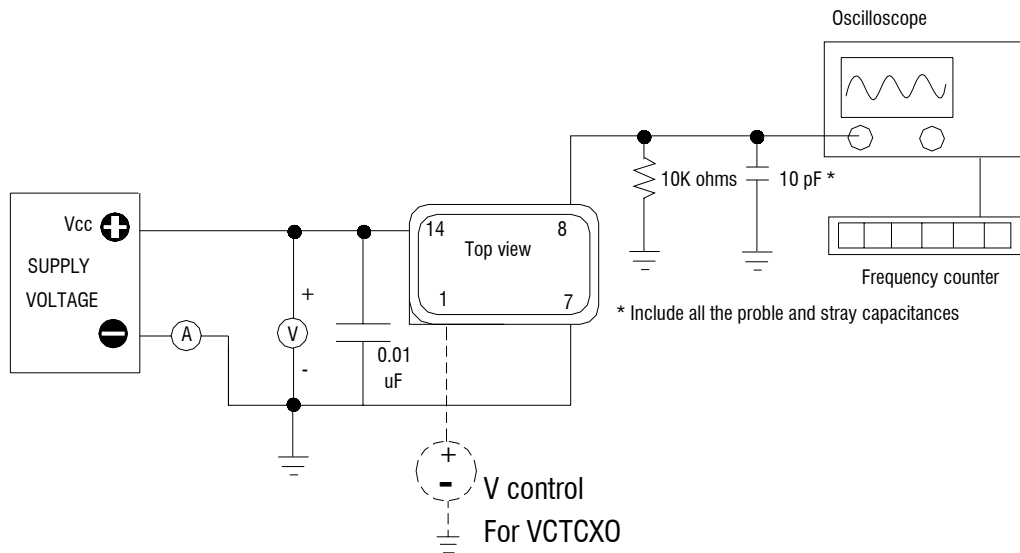

**Package: M38S,VM38S**

**Open bottom**

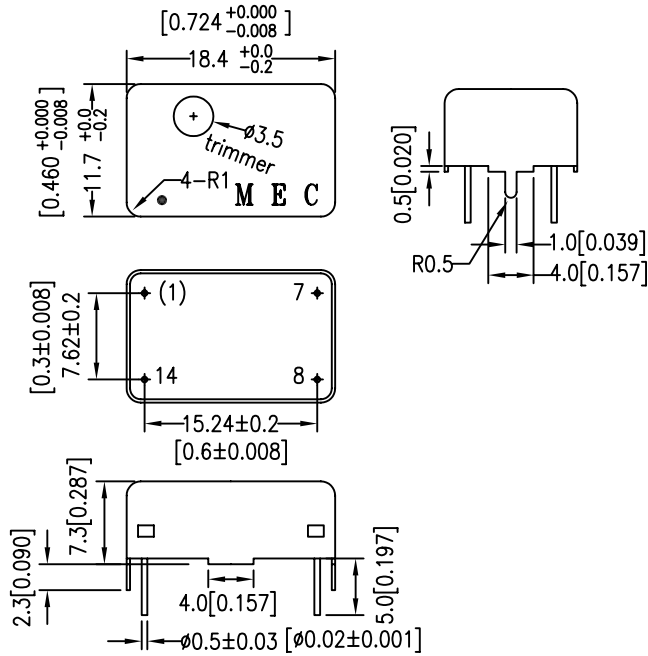

**Pin Connections**

- Pin 1: Voltage Control for VCTCXO; No physical pin 1 for TCXO
- Pin 7: Ground
- Pin 8: Output
- Pin 14: Supply Voltage

**Package: M39S,VM39S**

Unit: mm [inches]

**Open bottom**

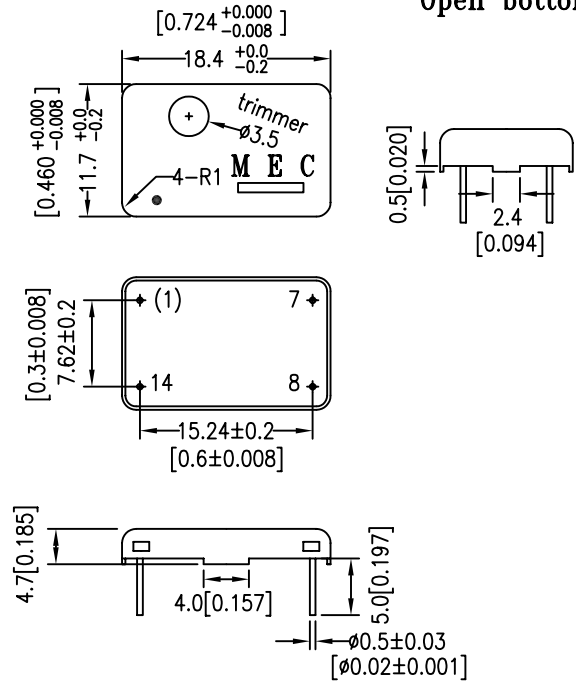

**Pin Connections**

- Pin 1: Voltage Control for VCTCXO; No physical pin 1 for TCXO
- Pin 7: Ground
- Pin 8: Output
- Pin 14: Supply Voltage

**Package: M47S,VM47S**

TCXO;VCTCXO

**Open bottom  
Gull wing SMD**

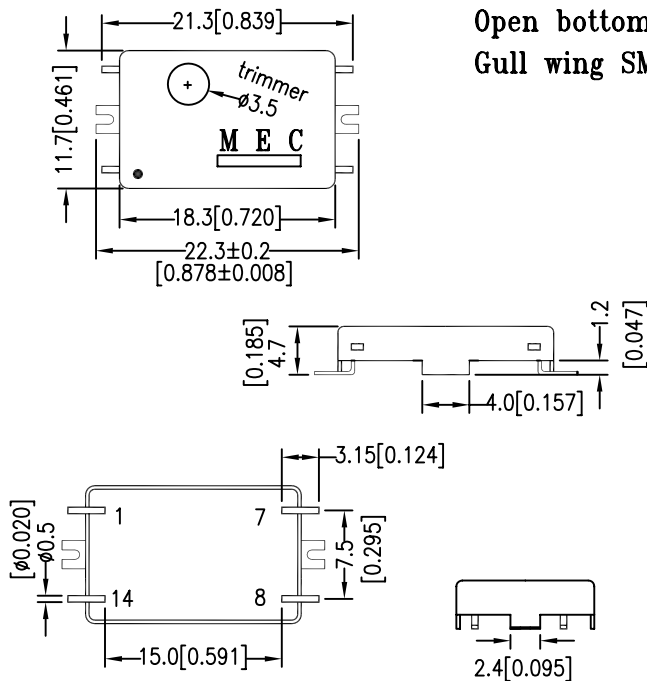

**Pin Connections**

- Pin 1: Voltage Control for VCTCXO. No Connection for TCXO.
- Pin 7: Ground
- Pin 8: Output
- Pin 14: Supply Voltage

**Package: M55S,VM55S**

**Open bottom  
Gull wing SMD**

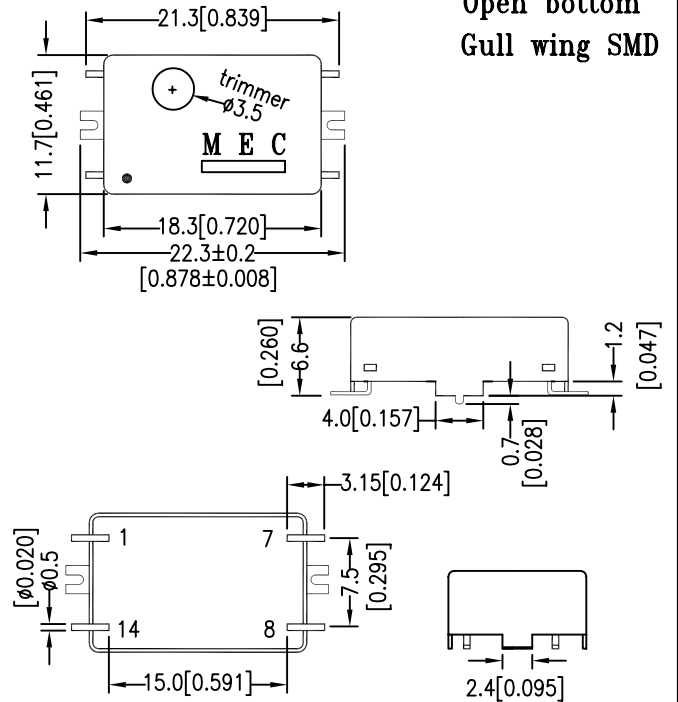

**Pin Connections**

- Pin 1: Voltage Control for VCTCXO. No Connection for TCXO.
- Pin 7: Ground
- Pin 8: Output
- Pin 14: Supply Voltage

**Package: M14S,VM14S Hermetically Sealed DIP No Trimmer Access**

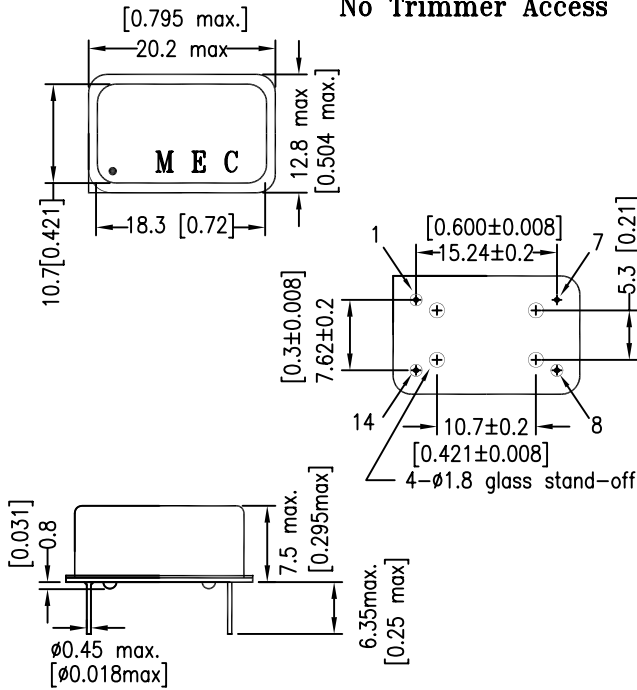

**Pin Connections** Square corner denotes pin 1  
 Pin 1: Voltage Control for VCTCXO; No Connection for TCXO  
 Pin 7: Ground  
 Pin 8: Output  
 Pin 14: Supply Voltage

**Package: M15S,VM15S Unit: mm [inches] Sealed bottom**

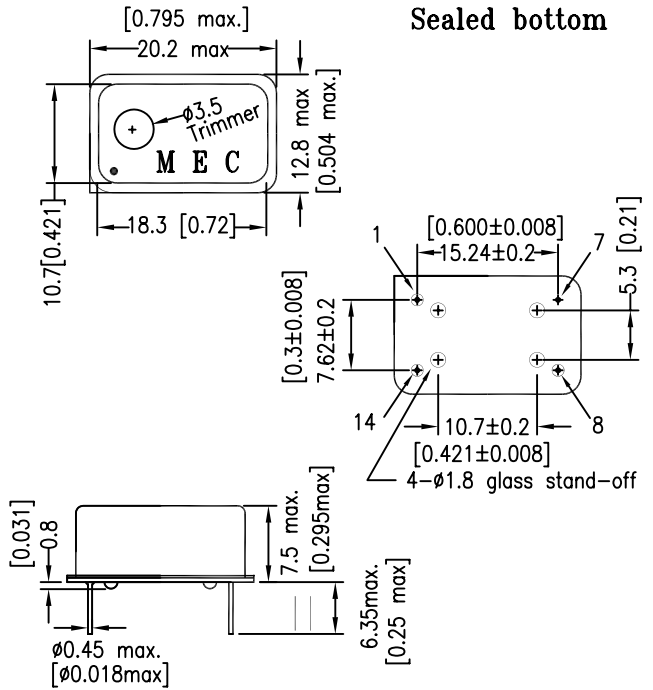

**Pin Connections** Square corner denotes pin 1  
 Pin 1: Voltage Control for VCTCXO; No Connection for TCXO  
 Pin 7: Ground  
 Pin 8: Output  
 Pin 14: Supply Voltage

TCXO;VCTCXO

**Package: M24S,VM24S Hermetically sealed No trimmer access**

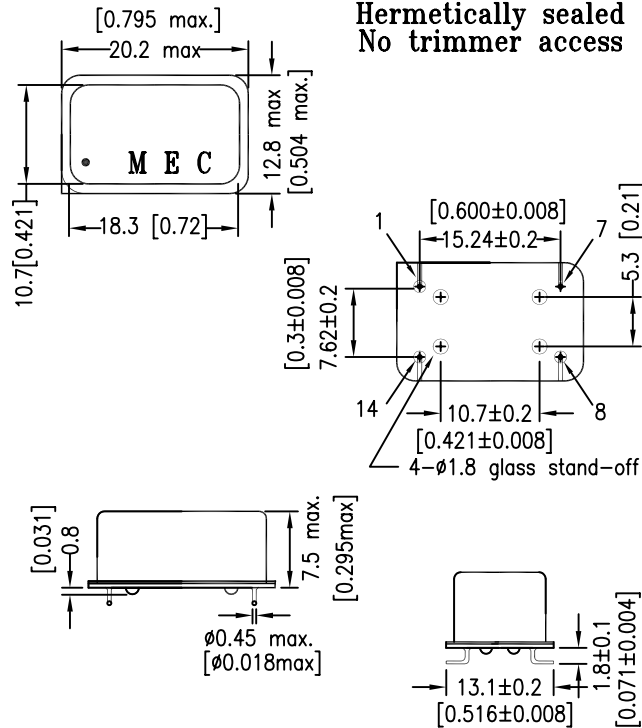

**Pin Connections** Square corner denotes pin 1  
 Pin 1: Voltage Control for VCTCXO; No Connection for TCXO  
 Pin 7: Ground  
 Pin 8: Output  
 Pin 14: Supply Voltage

**Package: M25S,VM25S Sealed bottom**

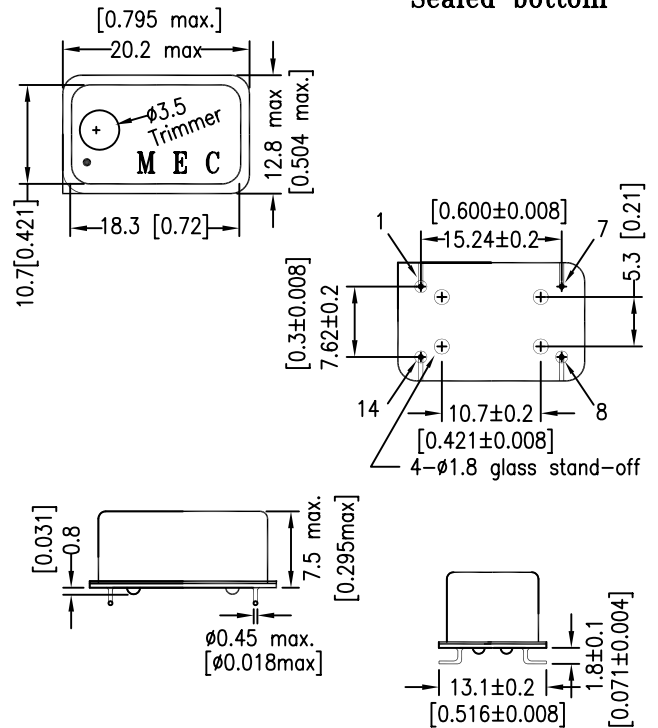

**Pin Connections** Square corner denotes pin 1  
 Pin 1: Voltage Control for VCTCXO; No Connection for TCXO  
 Pin 7: Ground  
 Pin 8: Output  
 Pin 14: Supply Voltage

Package: M8S,VM8S

Hermetically Sealed DIP  
No trimmer Access

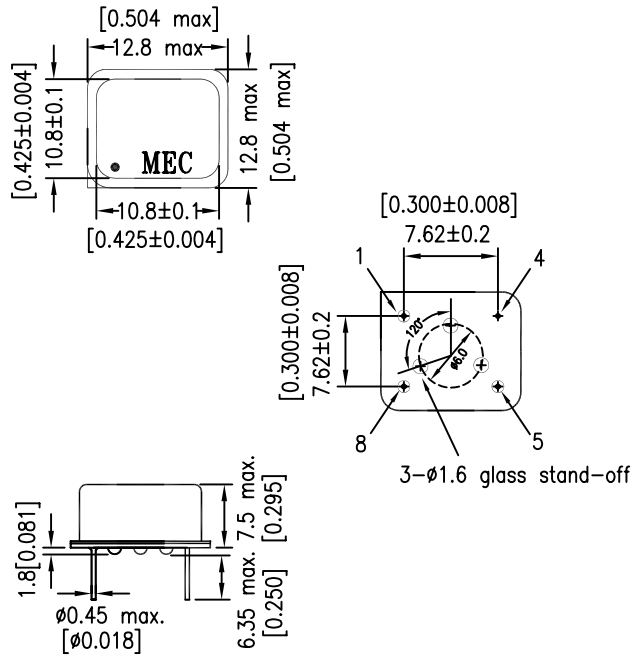

**Pin Connections**

Square corner denotes pin 1

- Pin 1: Voltage Control for VCTCXO or No Connection for TCXO
- Pin 4: Ground
- Pin 5: Output
- Pin 8: Supply Voltage

Package: M9S,VM9S

Unit: mm [inches]  
Sealed bottom

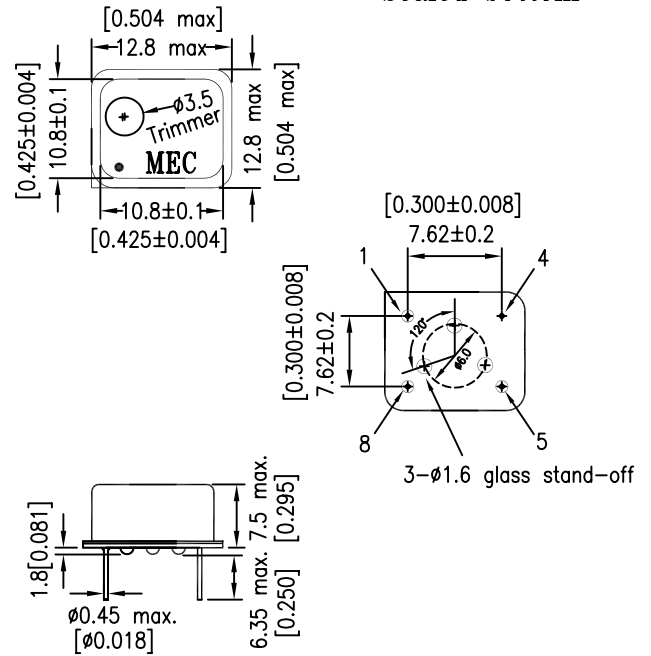

**Pin Connections**

Square corner denotes pin 1

- Pin 1: Voltage Control for VCTCXO or No Connection for TCXO
- Pin 4: Ground
- Pin 5: Output
- Pin 8: Supply Voltage

TCXO;VCTCXO

Package: M28S,VM28S

Hermetically Sealed  
Gull Wing SMD  
No trimmer Access

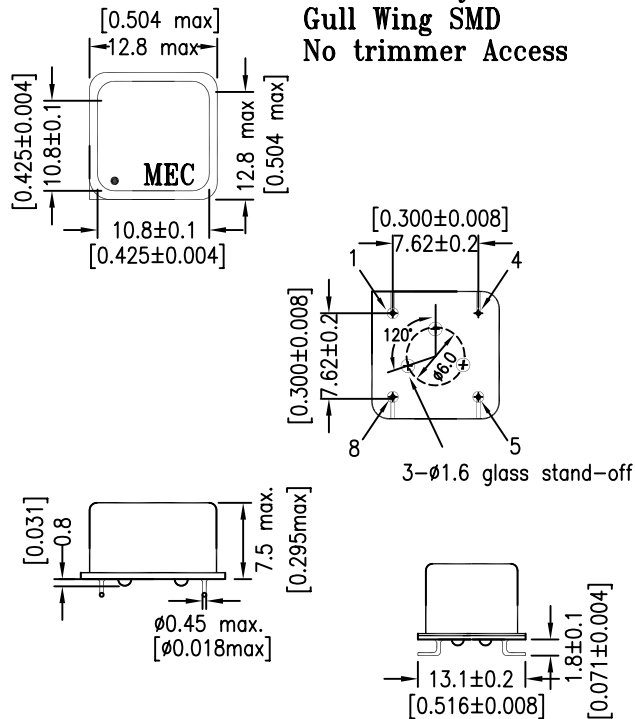

**Pin Connections**

Square corner denotes pin 1

- Pin 1: Voltage Control for VCTCXO or No Connection for TCXO
- Pin 4: Ground
- Pin 5: Output
- Pin 8: Supply Voltage

Package: M29S,VM29S

Sealed bottom  
Gull Wing SMD

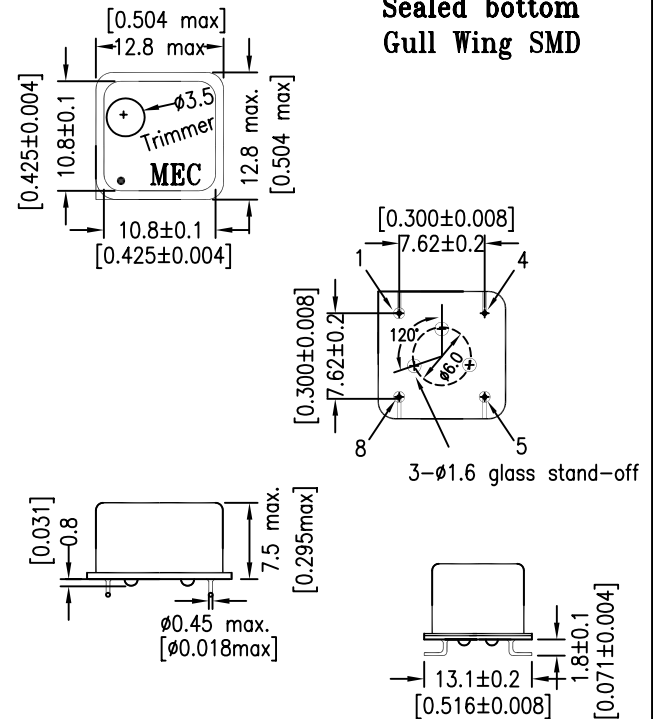

**Pin Connections**

Square corner denotes pin 1

- Pin 1: Voltage Control for VCTCXO or No Connection for TCXO
- Pin 4: Ground
- Pin 5: Output
- Pin 8: Supply Voltage

**Package: M42S,VM42S**

FR4 substrate

"42" represents 4 pads and 2.5 mm overall height

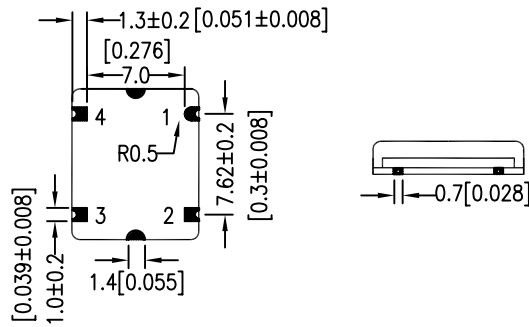
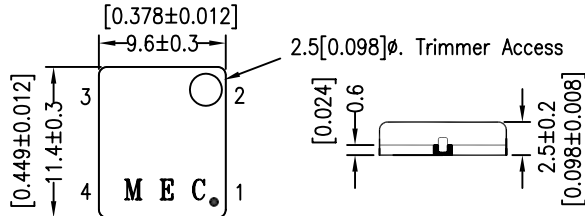

**Pad Connections:**

- Pad 1: Voltage Control for VCTCXO; No Connection for TCXO
- Pad 2: Ground
- Pad 3: Output
- Pad 4: Supply Voltage

**Package: M62S,VM62S**

FR4 substrate

"62" represents 6 pads and 2.5 mm overall height

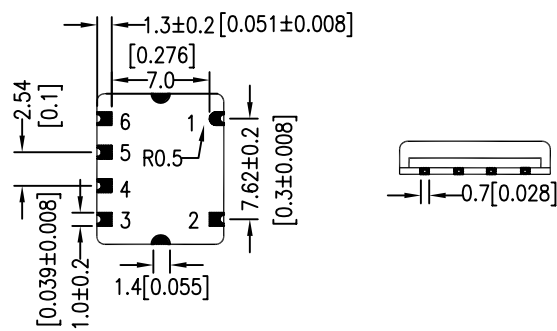
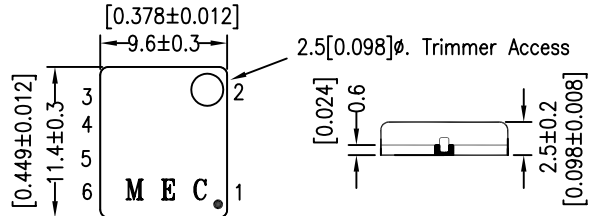

**Pad Connections:**

- Pad 1,2,4: Ground
- Pad 3: Output
- Pad 5: Voltage Control for VCTCXO; No Connection for TCXO
- Pad 6: Supply Voltage

**Package: M44S,VM44S**

FR4 substrate

"44" represents 4 pads and 4.7 mm overall height

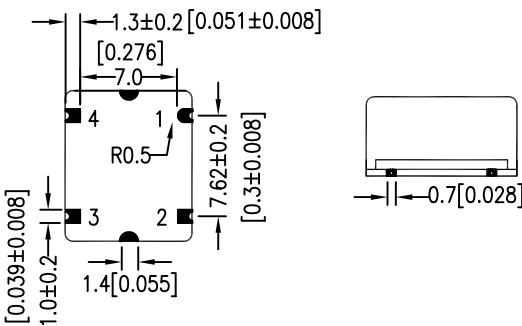
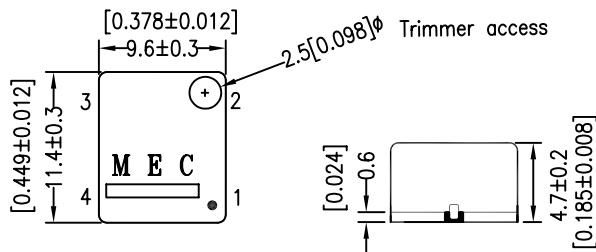

**Pad Connections:**

- Pad 1: Voltage Control for VCTCXO; No Connection for TCXO
- Pad 2: Ground
- Pad 3: Output
- Pad 4: Supply Voltage

**Package: M64S,VM64S**

FR4 substrate

"64" represents 6 pads and 4.7 mm overall height

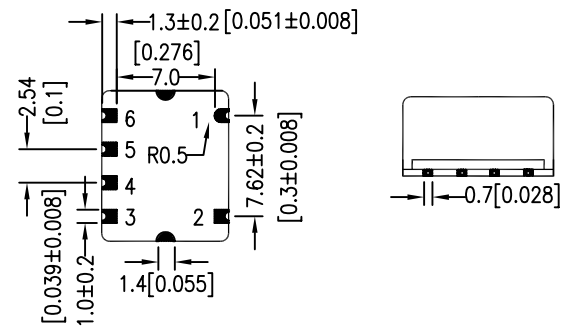
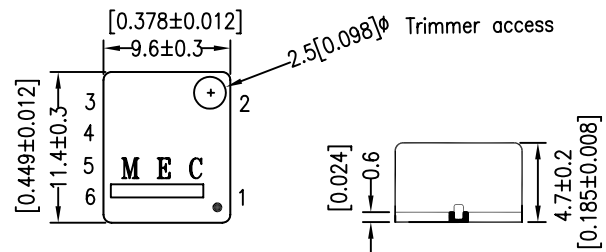

**Pad Connections:**

- Pad 1,2,4: Ground
- Pad 3: Output
- Pad 5: Voltage Control for VCTCXO; No Connection for TCXO
- Pad 6: Supply Voltage

TCXO;VCTCXO

**Package: M57S,VM57S**

Ceramic SMD

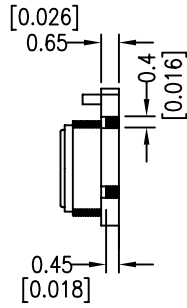
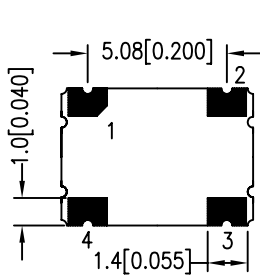
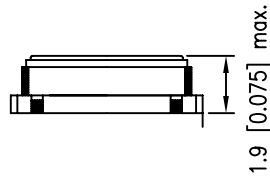
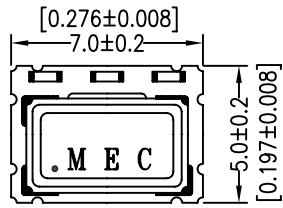

**Pad Connections:**

- Pad 1: Ground for TCXO; Voltage Control for VCTCXO
- Pad 2: Ground
- Pad 3: Output
- Pad 4: Supply Voltage

**Package: M53S,VM53S**

Ceramic SMD

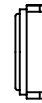
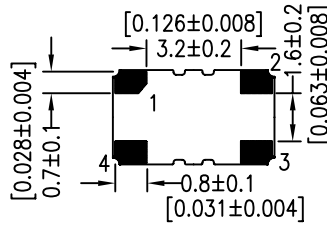
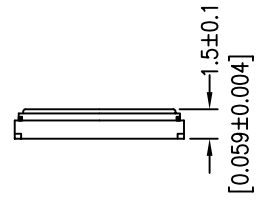
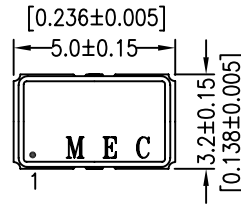

**Pad Connections:**

- Pad 1: Ground for TCXO; Voltage Control for VCTCXO
- Pad 2: Ground
- Pad 3: Output
- Pad 4: Supply Voltage

TCXO;VCTCXO