



**PRODUCT SELECTION GUIDE**

**Product Summary:**

Output Wave Form: Square Wave					
TCXO	VCTCXO	Available Frequency Range	RoHS Compliant Equivalent Model		Package Description
<b>Thru-Hole Types</b>					
M38T	VM38T	32.768 KHz	M38GT	VM38GT	4 pin DIP
M39T	VM39T		M39GT	VM39GT	4 pin DIP
M14T	VM14T		M14GT	VM14GT	4 pin DIP. Hermetically sealed.
M15T	VM15T		M15GT	VM15GT	4 pin DIP. With trimmer
M8T	VM8T		M8GT	VM8GT	4 pin DIP. Half size. Hermetically sealed.
M9T	VM9T		M9GT	VM9GT	4 pin DIP. Half size. With trimmer
<b>Gull Wing Surface Mount Types</b>					
M55T	VM55T	32.768 KHz	N / A	N / A	4 pin gull wing
M47T	VM47T		M47GT	VM47GT	4 pin gull wing
M24T	VM24T		M24GT	VM24GT	4 pin gull wing. Hermetically sealed.
M25T	VM25T		M25GT	VM25GT	4 pin gull wing. With trimmer
M28T	VM28T		M28GT	VM28GT	4 pin gull wing. Half size. Hermetically sealed.
M29T	VM29T		M29GT	VM29GT	4 pin Gull wing. Half size. With trimmer
<b>Leadless Surface Mount Types</b>					
M62T	VM62T	32.768 KHz	M62GT	VM62GT	6 pad FR4 substrate. 2.5 mm H
M42T	VM42T		M42GT	VM42GT	4 pad FR4 substrate. 2.5mm H
M64T	VM64T		M64GT	VM64GT	6 pad FR4 substrate. 4.7 mm H
M44T	VM44T		M44GT	VM44GT	4 pad FR4 substrate. 4.7 mm H
M57T	VM57T	Under development	Same <sup>(1)</sup>	Same <sup>(1)</sup>	4 pad ceramic substrate. 5x7 mm
M53T	VM53T		Same <sup>(1)</sup>	Same <sup>(1)</sup>	4 pad ceramic substrate. 5x3.2 mm

For RoHS equivalent model please add “G” after the package code. For example: M14GT3.

<sup>(1)</sup> M57T, VM57T, M53T and VM53T are RoHS compliant and lead free products. .

Note: Frequency tuning by the built-in mechanical trimmer is standard for all models except for M57T, VM57T, M53T and VM53T.

**Product Options**

- No mechanical Trimmer models are available to allow for aqueous washing.
- Narrow ( $\pm 1$  ppm max.) or wide electrical tuning range ( $\pm 35$  ppm max.)
- +15V, +12V, +10V or +9V DC supply voltages are also available in some packages.

**MERCURY [www.mercury-crystal.com](http://www.mercury-crystal.com)**

Taiwan: TEL (886)-2-2406-2779, FAX (886)-2-0769, e-mail: [sales-tw@mercury-crystal.com](mailto:sales-tw@mercury-crystal.com)

U.S.A.: TEL (1)-909-466-0427, FAX (1)-909-466-0762, e-mail: [sales-us@mercury-crystal.com](mailto:sales-us@mercury-crystal.com)

**“TCXO” and “VCTCXO” “T” Series 32.768 KHz**  
**Wave Form: Square Wave**



**MERCURY**  
 Since 1973

**General Specifications** (at +25°C and specified input voltage)

<b>Frequency</b>		32.768 KHz						
<b>Output Wave Form</b>		<b>Square</b> wave. Wave form code is “T”						
<b>Initial Calibration Tolerance</b>		Models with mechanical trimmer: <math>\pm 1\text{ ppm}</math>. +25°C $\pm 2^\circ\text{C}</math>.Models without mechanical trimmer: \pm 2\text{ ppm}</math> at +25°C \pm 2^\circ\text{C}</math>.$						
<b>Frequency Stability</b> vs Temperature vs Aging vs Voltage Change vs Load Change vs reflow (SMD models only)		$\pm 1\text{ ppm}</math>, \pm 1.5\text{ ppm}</math>, \pm 2.0\text{ ppm}</math>, \pm 2.5\text{ ppm}</math>, \pm 3\text{ ppm}</math>, or \pm 5\text{ ppm}</math>, over operating temperature range. Referenced to frequency reading at +25°C.\pm 1.0\text{ ppm}</math> max. first year at +25°C\pm 0.3\text{ ppm}</math> max. for a \pm 5\% input voltage change\pm 0.3\text{ ppm}</math> max. for a \pm 10\% loading condition change\pm 1\text{ ppm}</math> max. 1 reflow and measured 24 hours afterwards$						
<b>Typical Operating Temperature Range (examples)</b>		0°C to +60°C    0°C to +70°C    -10°C to +60°C -20 °C to +70°C    -30°C to +60°C    -30°C to +75°C -30°C to +85°C    -40°C to +85°C. or custom. Hi Rel: -55°C to +85°C or -55°C to +125°C. Selected models only. Customer package and /or pin configurations are welcome.						
<b>Output Voltage Level (peak to peak)</b>		CMOS						
<b>Mechanical Frequency Tuning</b>		<b>Standard</b>		$\pm 3\text{ ppm}</math> min. tuningNote: VM57 and VM53 have no mechanical trimmer built-in.$				
		<b>Option</b>		No mechanical trimmer built-in (for aqueous washing cycles). Part number: Please add “1” after the regular model prefix. For example: M381T3.				
<b>Input Voltage Range</b>		<b>Option</b>		+15.0V, +12.0V, +10.0V, +9.0; +3.0 V D.C.				
		<b>Standard</b>		+ 2.75 V D.C. min.; +5.0 V D.C. max. +3.3 V (voltage code is “33”)    +5.0 V (voltage code is “5”)				
<b>Output Voltage Level</b>		<b>Logic High “1”</b>		2.4 V typ.; 2.2 V min.		4.2 V typ.; 3.9 V min.		
		<b>Logic Low “0”</b>		0.3 V typ.; 0.4 V max.		0.3 V typ.; 0.4 V max.		
<b>Current Consumption. (Over operating temperature range.)</b>		3.5 mA typical.			7.0 mA typical			
<b>Duty Cycle</b>		45% ~55%						
<b>Rise Time (0.1V<sub>DD</sub> → 0.9 V<sub>DD</sub>)</b>		3.0 n sec. typical; 5.0 n sec max.						
<b>Fall Time (0.9V<sub>DD</sub> → 0.1 V<sub>DD</sub>)</b>		3.0 n sec. typical; 5.0 n sec max.						
<b>Pin 1 Options</b>	<b>VCTCXO only</b>	<b>Control voltage</b>		+1.5 V $\pm 1.0\text{ V}$		+2.5 V $\pm 2.0\text{ V}$ . +1.5 V $\pm 1.0\text{ V}$ for VM57T5		
		<b>Frequency Deviation Range</b>	<b>Standard</b>		$\pm 10\text{ ppm}</math> min. for +1.5 V \pm 1.0\text{ V}$			
			<b>Option</b>		Narrow: $\pm 1\text{ ppm}</math> max. or customWide: \pm 35\text{ min.}</math> or custom$			
		<b>Slope Polarity</b>	<b>Standard</b>		Positive slope. Positive voltage for positive frequency shift.			
			<b>Option</b>		Negative slope. Selected packages only.			
<b>Linearity</b>		10 % max.						
<b>SSB Phase Noise</b>		<b>Offset</b>		10 Hz	100 Hz	1 KHz	10 KHz	100 KHz
		<b>typical</b>		-65 dBc/Hz	-100 dBc/Hz	-130 dBc/Hz	-140 dBc/Hz	-145 dBc/Hz
<b>Start-Up Time.</b>		2 m. sec. Typical, 10 m. sec. max. (reach 90% amplitude and at +25°C $\pm 2^\circ\text{C}$ )						
<b>Output Load</b>		15 pF						
<b>Output Format</b>		AC block, DC coupled						
<b>Storage Temperature</b>		-40°C to +85°C or -55°C to +125°C (package dependent)						

**Note 1:** Some specifications are package dependent. Please refer to the spec. sheet of individual packages once a package is selected..

**Note 2:** TCXO products ordered without mechanical and electrical frequency tuning should have a frequency tolerance of  $\pm 2$

**“TCXO” and “VCTCXO” “T” Series 32.768 KHz  
Wave Form: Square Wave**



**MERCURY**  
Since 1973

ppm (at +25°C) and the frequency stability over temperature will be from that measured value.

**Part Number Format and Examples:**

<b>Example of TCXO: M38T33-32.768K-2.5/-30+75;</b> <b>Example of VCTCXO: VM38T5-32.768K-2.5/-30+75</b>										
<del>/</del>	<del>/</del>		<del>/</del>		<del>/</del>		<del>/</del>		<del>/</del>	<del>/</del> : customer to specify
V	M38	T	5	—	32.768K	—	2.5	/	-30+75	
❶	❷	❸	❹		❺		❻		❼	
<b>❶: “V” for VCTCXO; “blank” for TCXO</b> <b>❷: Package code</b> <b>❸: Wave form code “T” for Square wave</b> <b>❹: Supply voltage code: “28” for +2.8V, “3” for +3.0V, “33” for “+3.3V, “5” for +5.0V</b> <b>❺: Frequency in MHz</b> <b>❻: Frequency stability in ±ppm</b> <b>❼: Operating temperature range in °C</b>										

**Square Wave TCXO (VCTCXO) Test Circuit (example of VM14) and Output Wave Form:**

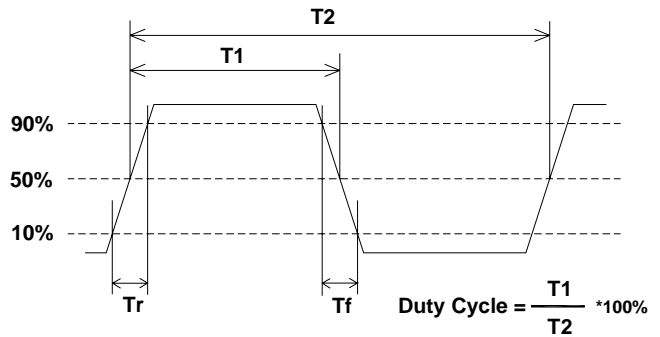
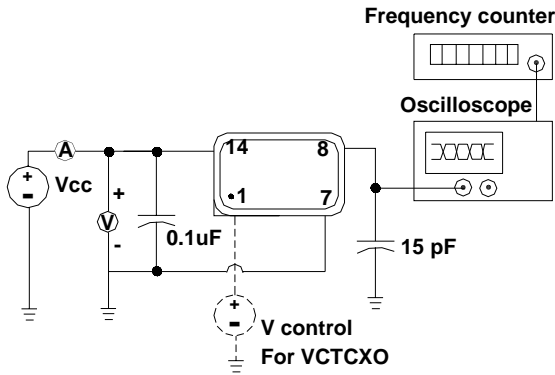

**Package: M38S,VM38S**

**Open bottom**

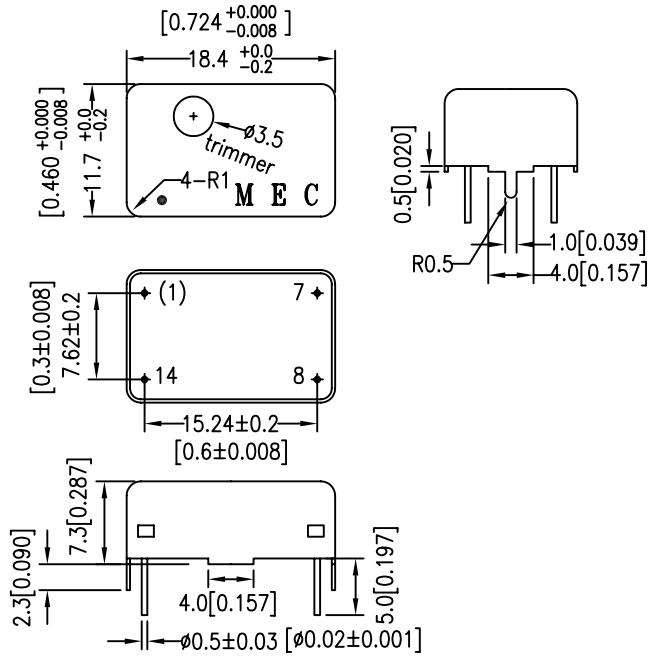

**Pin Connections**

- Pin 1: Voltage Control for VCTCXO; No physical pin 1 for TCXO
- Pin 7: Ground
- Pin 8: Output
- Pin 14: Supply Voltage

**Package: M39S,VM39S**

**Unit: mm [inches]**

**Open bottom**

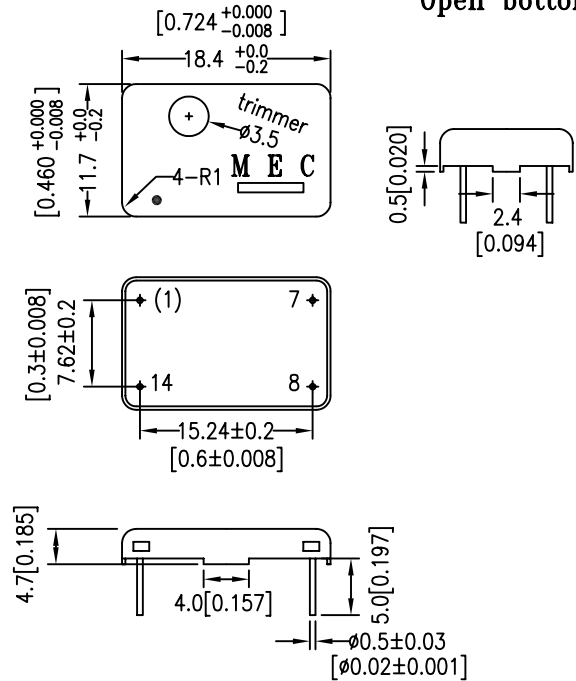

**Pin Connections**

- Pin 1: Voltage Control for VCTCXO; No physical pin 1 for TCXO
- Pin 7: Ground
- Pin 8: Output
- Pin 14: Supply Voltage

TCXO;VCTCXO

**Package: M47S,VM47S**

**Open bottom  
Gull wing SMD**

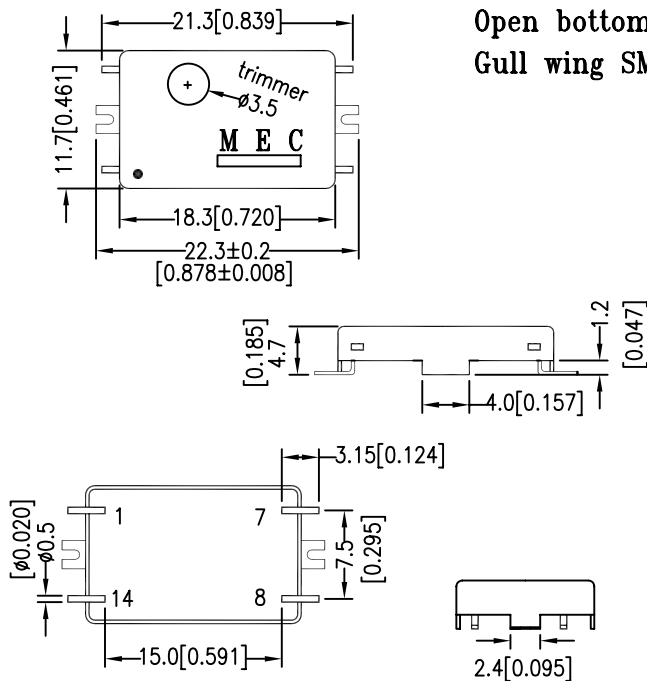

**Pin Connections**

- Pin 1: Voltage Control for VCTCXO. No Connection for TCXO.
- Pin 7: Ground
- Pin 8: Output
- Pin 14: Supply Voltage

**Package: M55S,VM55S**

**Open bottom  
Gull wing SMD**

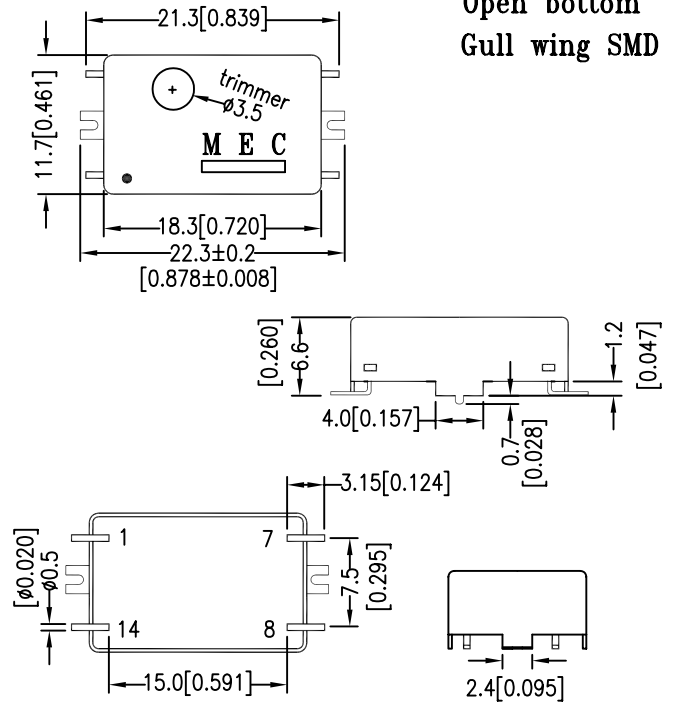

**Pin Connections**

- Pin 1: Voltage Control for VCTCXO. No Connection for TCXO.
- Pin 7: Ground
- Pin 8: Output
- Pin 14: Supply Voltage

**Package: M14S,VM14S** Hermetically Sealed DIP  
No Trimmer Access

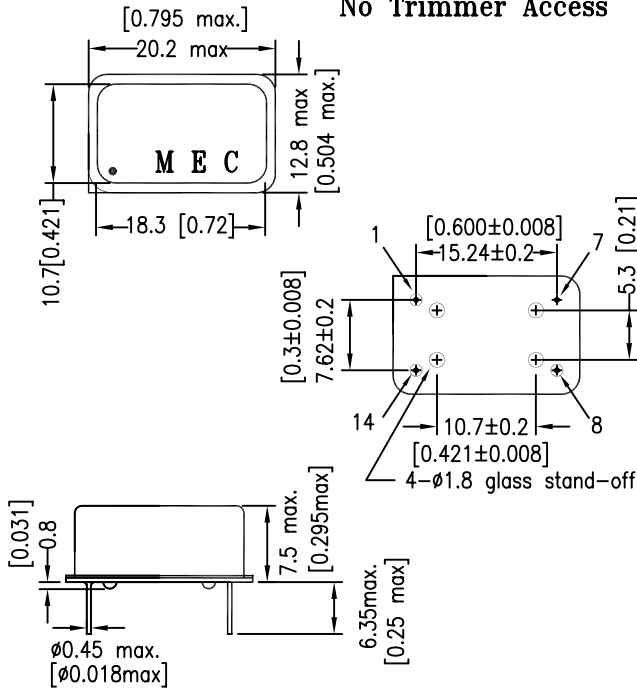

**Pin Connections** Square corner denotes pin 1  
 Pin 1: Voltage Control for VCTCXO; No Connection for TCXO  
 Pin 7: Ground  
 Pin 8: Output  
 Pin 14: Supply Voltage

**Package: M15S,VM15S** Unit: mm [inches]  
Sealed bottom

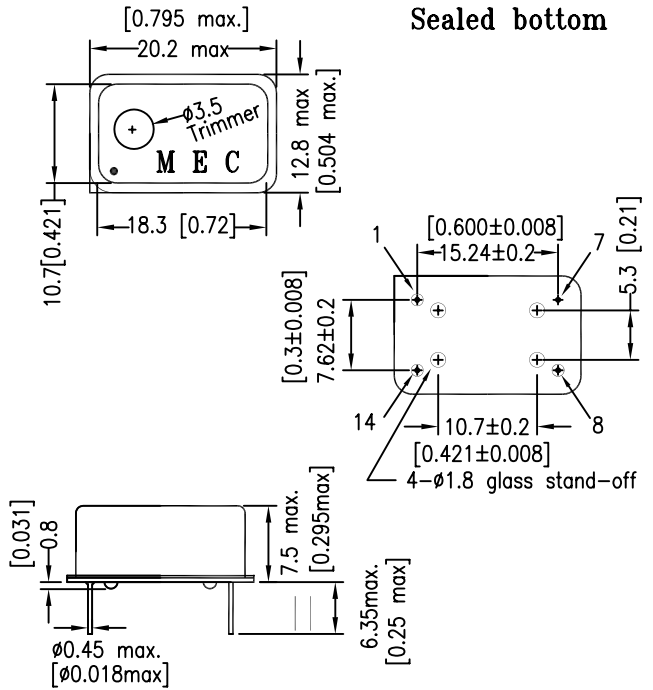

**Pin Connections** Square corner denotes pin 1  
 Pin 1: Voltage Control for VCTCXO; No Connection for TCXO  
 Pin 7: Ground  
 Pin 8: Output  
 Pin 14: Supply Voltage

TCXO;VCTCXO

**Package: M24S,VM24S** Hermetically sealed  
No trimmer access

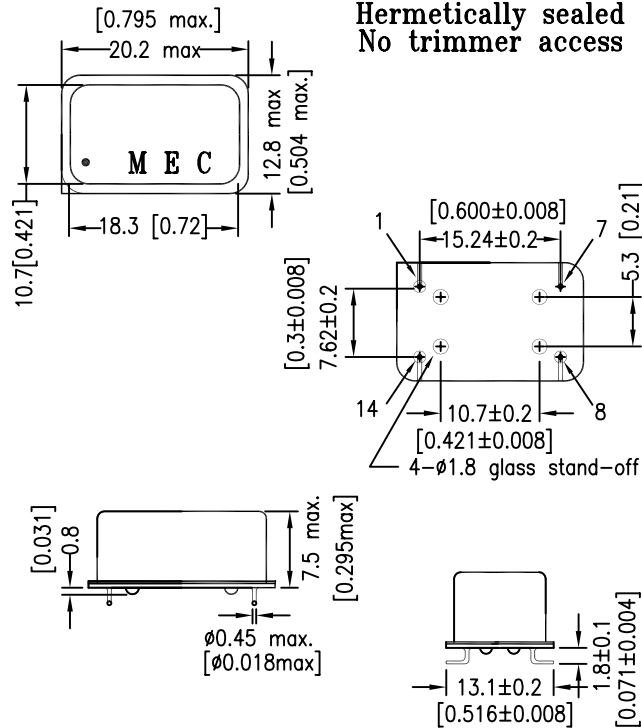

**Pin Connections** Square corner denotes pin 1  
 Pin 1: Voltage Control for VCTCXO; No Connection for TCXO  
 Pin 7: Ground  
 Pin 8: Output  
 Pin 14: Supply Voltage

**Package: M25S,VM25S** Sealed bottom

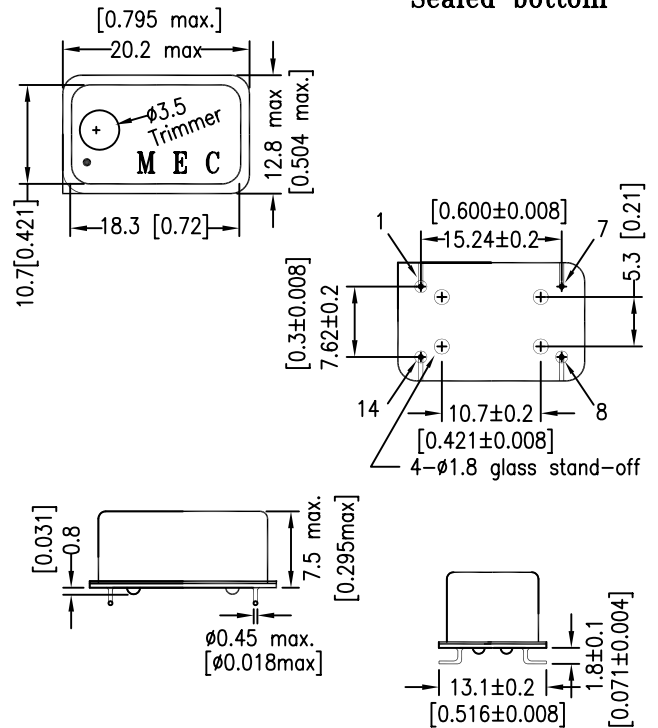

**Pin Connections** Square corner denotes pin 1  
 Pin 1: Voltage Control for VCTCXO; No Connection for TCXO  
 Pin 7: Ground  
 Pin 8: Output  
 Pin 14: Supply Voltage

Package: M8S,VM8S

Hermetically Sealed DIP  
No trimmer Access

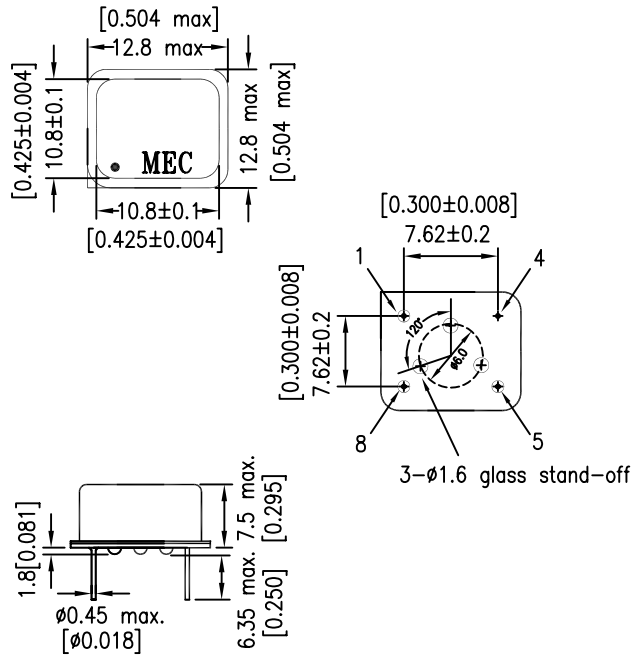

**Pin Connections**

Square corner denotes pin 1

- Pin 1: Voltage Control for VCTCXO or No Connection for TCXO
- Pin 4: Ground
- Pin 5: Output
- Pin 8: Supply Voltage

Package: M9S,VM9S

Unit: mm [inches]  
Sealed bottom

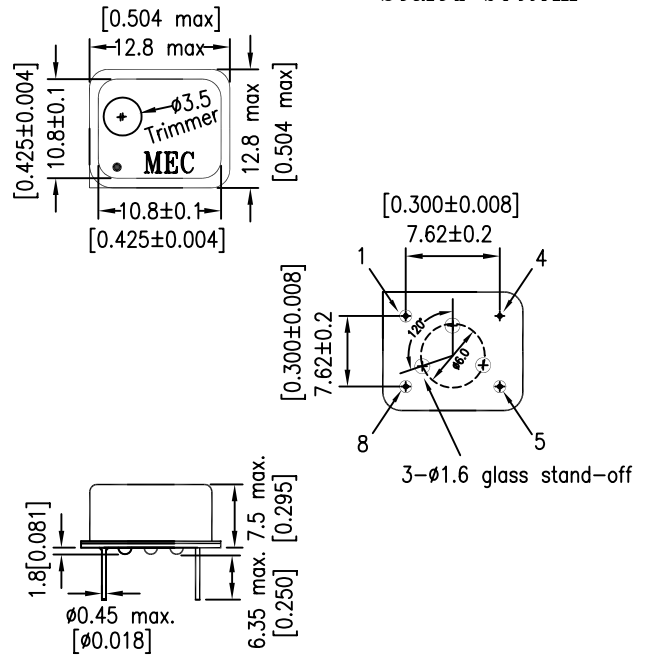

**Pin Connections**

Square corner denotes pin 1

- Pin 1: Voltage Control for VCTCXO or No Connection for TCXO
- Pin 4: Ground
- Pin 5: Output
- Pin 8: Supply Voltage

TCXO;VCTCXO

Package: M28S,VM28S

Hermetically Sealed  
Gull Wing SMD  
No trimmer Access

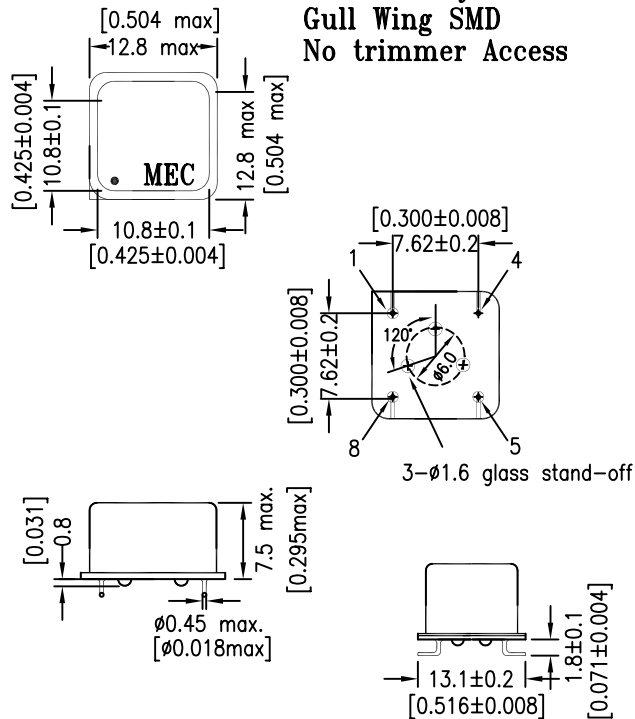

**Pin Connections**

Square corner denotes pin 1

- Pin 1: Voltage Control for VCTCXO or No Connection for TCXO
- Pin 4: Ground
- Pin 5: Output
- Pin 8: Supply Voltage

Package: M29S,VM29S

Sealed bottom  
Gull Wing SMD

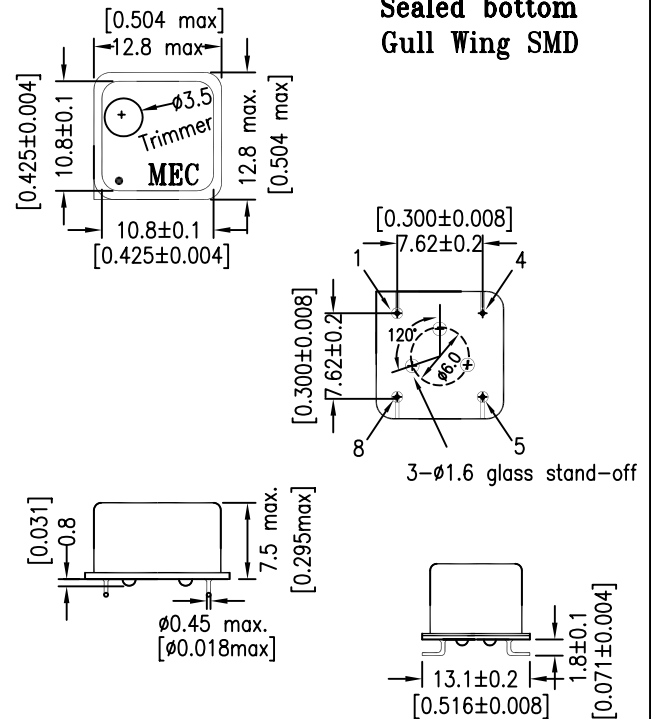

**Pin Connections**

Square corner denotes pin 1

- Pin 1: Voltage Control for VCTCXO or No Connection for TCXO
- Pin 4: Ground
- Pin 5: Output
- Pin 8: Supply Voltage

**Package: M42S,VM42S**

FR4 substrate

"42" represents 4 pads and 2.5 mm overall height

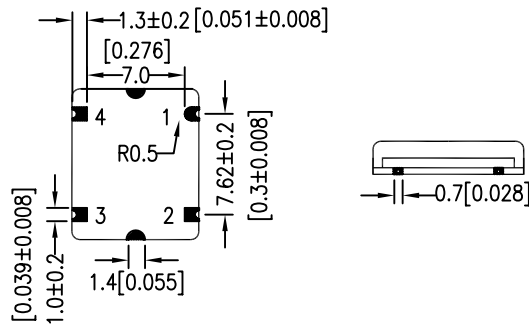
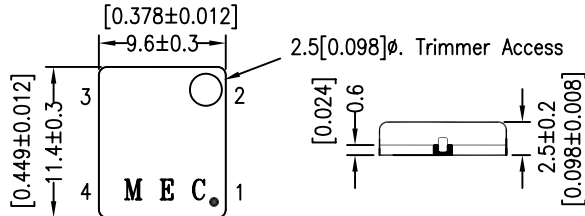

**Pad Connections:**

- Pad 1: Voltage Control for VCTCXO; No Connection for TCXO
- Pad 2: Ground
- Pad 3: Output
- Pad 4: Supply Voltage

**Package: M62S,VM62S**

FR4 substrate

"62" represents 6 pads and 2.5 mm overall height

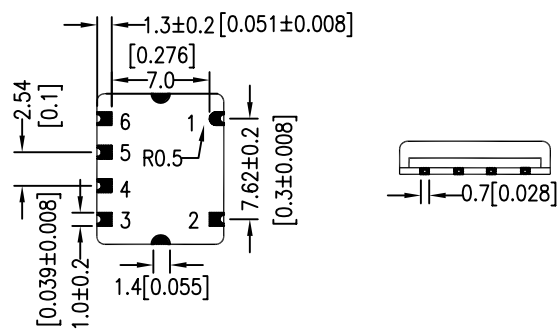
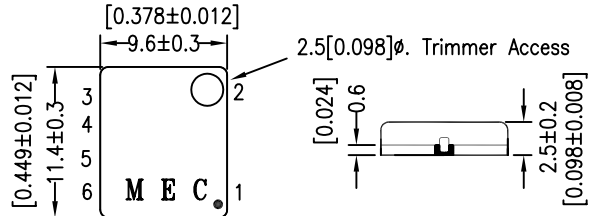

**Pad Connections:**

- Pad 1,2,4: Ground
- Pad 3: Output
- Pad 5: Voltage Control for VCTCXO; No Connection for TCXO
- Pad 6: Supply Voltage

**Package: M44S,VM44S**

FR4 substrate

"44" represents 4 pads and 4.7 mm overall height

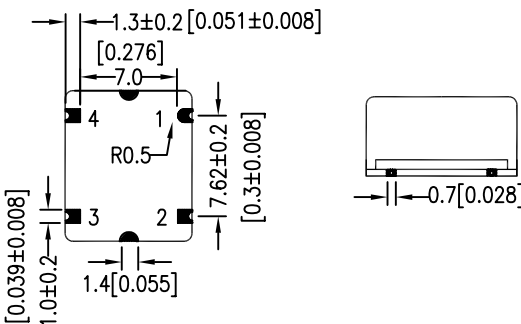
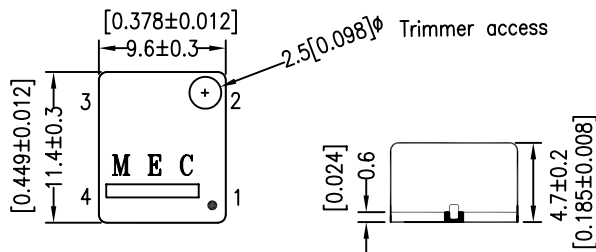

**Pad Connections:**

- Pad 1: Voltage Control for VCTCXO; No Connection for TCXO
- Pad 2: Ground
- Pad 3: Output
- Pad 4: Supply Voltage

**Package: M64S,VM64S**

FR4 substrate

"64" represents 6 pads and 4.7 mm overall height

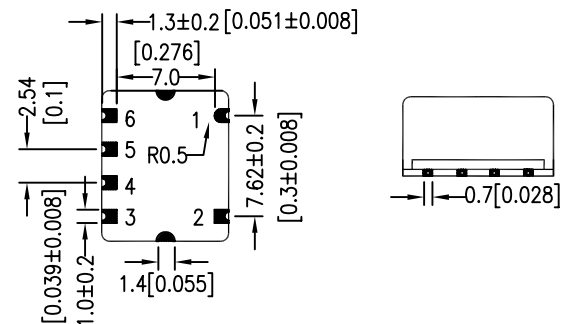
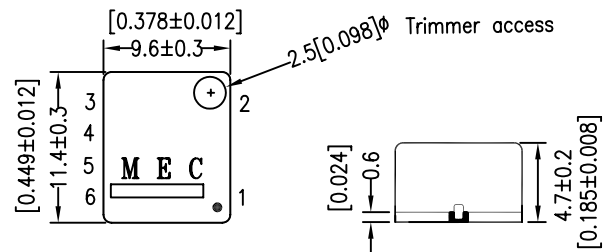

**Pad Connections:**

- Pad 1,2,4: Ground
- Pad 3: Output
- Pad 5: Voltage Control for VCTCXO; No Connection for TCXO
- Pad 6: Supply Voltage

TCXO;VCTCXO

**Package: M57S,VM57S**

Ceramic SMD

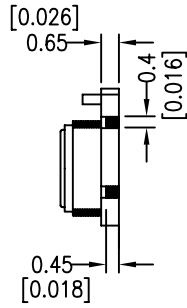
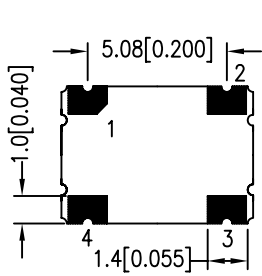
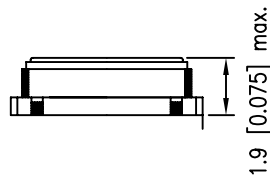
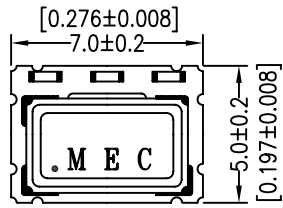

**Pad Connections:**

- Pad 1: Ground for TCXO; Voltage Control for VCTCXO
- Pad 2: Ground
- Pad 3: Output
- Pad 4: Supply Voltage

**Package: M53S,VM53S**

Ceramic SMD

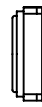
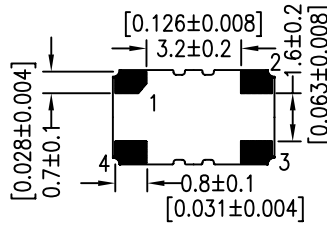
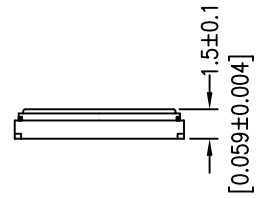
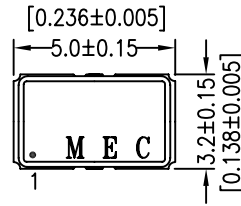

**Pad Connections:**

- Pad 1: Ground for TCXO; Voltage Control for VCTCXO
- Pad 2: Ground
- Pad 3: Output
- Pad 4: Supply Voltage

TCXO;VCTCXO