

**OCXO (Oven Controlled Crystal Oscillators)
OC14T5A, OC14T5GA (RoHS version), HCMOS Square Wave**

+5.0 V



MERCURY
Since 1973

- Full size 4 pin DIP full metal package
- +5.0 V D.C supply Voltage
- 15 pF load HCMOS square wave output
- AT-cut crystal
- Voltage control (Electronic Frequency Tuning) on pin 1



General Specifications (10 MHz at +25°C, at +5.0 V Vcc and +2.5 V Vcon)

Output Wave Form		HCMOS Square Wave. Wave form code is "T"				
Frequency Range		1.25 MHz ~100.0 MHz. Note: 40 MHz max. for RoHS version				
Type of Crystal Cut Used		AT-cut. Use "A" for crystal code.				
Supply Voltage (Vcc)		+5.0 V ±0.2 V (voltage code is "5")				
Initial Calibration Tolerance		±0.5 ppm max. at the time of shipment. Vcon = +2.5V				
Frequency Stability vs	Operating Temperature Range (custom spec. on request)	Operating Temperature	0°C to +60°C	-20°C to +70°C	-40°C to +85°C	
		Best Stability Available	±0.025 ppm	±0.05 ppm	±0.1 ppm	
		Typical Stability	±0.2 ppm	±0.3 ppm	±0.5 ppm	
	Aging	< ±0.7 ppm first year. < ±4.0 ppm over 10 years.				
	Short Term Stability	< 1 E ⁻¹⁰ (0.1 sec to 30 sec.); typical 5 E ⁻¹¹ at 1 sec.				
	Supply Voltage ±0.2V Variation	< ±0.1 ppm				
	Load ±5% variation	< ±0.01 ppm				
Warm-up time (at +25°C)	3 minutes max. Within ±0.1 ppm of its reference frequency.					
Voltage Control on pin 1 (EFC) (Electronics Frequency Tuning)	Freq. Deviation Range	±4 ppm min. Referenced to fo at +25°C				
	Control Voltage Range	0.0 V to 5.0 V				
	Transfer Function	Positive: Increasing control voltage increases output frequency.				
	Input Impedance	47 K ohms min.				
	EFC Linearity	±10% max.				
Power	Power Dissipation (at +25°C)	1.5 Watts max. at steady-state. 2.5 Watts max. at turn-on.				
Output	Load (Fan Out)	10 LS				
	Duty Cycle (measured at 1/2Vcc)	50% ±10%				
	Output Voltage Logic High (V_{OH})	+4.5 V min				
	Output Voltage Logic Low (V_{OL})	+0.4 V max.				
	Rise and Fall Time	7 nS max. (measured at 20% ± 80% of waveform.)				
	Phase Noise	Offset	1 Hz	10 Hz	100 Hz	1 KHz
10 MHz at static condition		-70 dBc	-100 dBc	-130 dBc	-140 dBc	-145 dBc
Storage Temperature		-65°C to +125°C				
Shock		2000 G's, 0.3 ms ½ sine				
Vibration		10 to 2000 Hz / 10 G's				

MERCURY www.mercury-crystal.com

Taiwan: TEL (886)-2-2406-2779, FAX (886)-2-2496-0769, e-mail: sales-tw@mercury-crystal.com
 U.S.A.: TEL (1)-909-466-0427, FAX (1)-909-466-0762, e-mail: sales-us@mercury-crystal.com



OC14T5A Test Circuit:

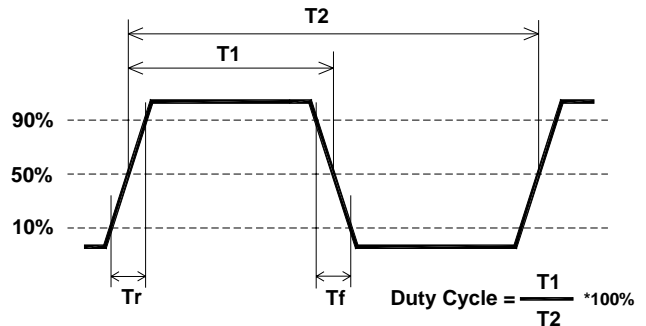
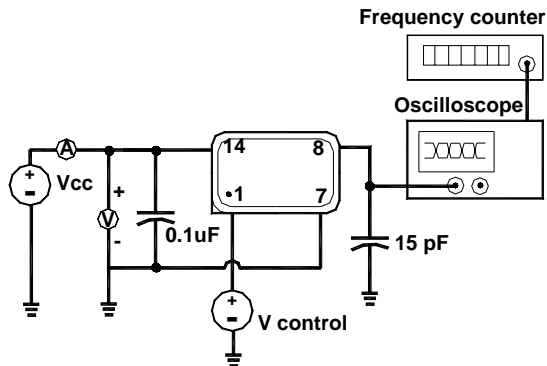

OC14T5A Package Dimensions and Pin Connections:

Pin 1: Voltage Control (EFC) Pin 7: Ground / Case
 Pin 8: Output Pin 14: Supply Voltage

unit mm [inches]
 Square corner is pin No. 1

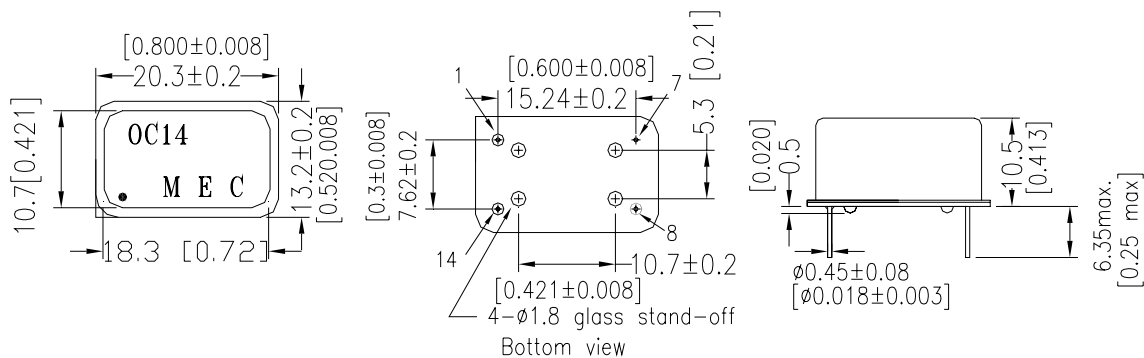

Part Number Format and Example:

Example: OC14T5GA-10.000-0.1/-20+70

OC	14	T	5	G	A	—	10.000	—	0.1	/	-20+70
①	②	③	④	⑤	⑥	dash	⑦	dash	⑧	slash	⑨

①: "OC" Product Prefix for OCXO **②**: Package type. "14" for 4 pin DIP.
③: Output wave form code. "T" for HCMOS square wave.
④: Supply voltage code. "5" for +5.0V;
⑤: "G" for RoHS compliant equivalent, " " (blank) for non-RoHS part.
⑥: Crystal type. "A" for AT-cut crystal;
⑦: Frequency in MHz; **⑧**: Frequency stability in ppm;
⑨: Operating temperature range: -20°C to +70°C in this case.