

---

**EM78P510N**

**8-Bit Microprocessor  
with OTP ROM**

**Product  
Specification**

**Doc. Version 1.0**

**ELAN MICROELECTRONICS CORP.**

March 2007

---



**Trademark Acknowledgments:**

IBM is a registered trademark and PS/2 is a trademark of IBM.

Windows is a trademark of Microsoft Corporation

ELAN and ELAN logo  are trademarks of ELAN Microelectronics Corporation

Copyright © 2007 by ELAN Microelectronics Corporation

All Rights Reserved

Printed in Taiwan

The contents of this specification are subject to change without further notice. ELAN Microelectronics assumes no responsibility concerning the accuracy, adequacy, or completeness of this specification. ELAN Microelectronics makes no commitment to update, or to keep current the information and material contained in this specification. Such information and material may change to conform to each confirmed order.

In no event shall ELAN Microelectronics be made responsible for any claims attributed to errors, omissions, or other inaccuracies in the information or material contained in this specification. ELAN Microelectronics shall not be liable for direct, indirect, special incidental, or consequential damages arising from the use of such information or material.

The software (if any) described in this specification is furnished under a license or nondisclosure agreement, and may be used or copied only in accordance with the terms of such agreement.

ELAN Microelectronics products are not intended for use in life support appliances, devices, or systems. Use of ELAN Microelectronics product in such applications is not supported and is prohibited.

NO PART OF THIS SPECIFICATION MAY BE REPRODUCED OR TRANSMITTED IN ANY FORM OR BY ANY MEANS WITHOUT THE EXPRESSED WRITTEN PERMISSION OF ELAN MICROELECTRONICS.



**ELAN MICROELECTRONICS CORPORATION**

**Headquarters:**

No. 12, Innovation Road 1  
Hsinchu Science Park  
Hsinchu, Taiwan 30077  
Tel: +886 3 563-9977  
Fax: +886 3 563-9966  
<http://www.emc.com.tw>

**Hong Kong:**

**Elan (HK) Microelectronics Corporation, Ltd.**  
Flat A, 19F., World Tech Centre  
95 How Ming Street, Kwun Tong  
Kowloon, HONG KONG  
Tel: +852 2723-3376  
Fax: +852 2723-7780  
[elanhk@emc.com.hk](mailto:elanhk@emc.com.hk)

**USA:**

**Elan Information Technology Group (USA)**  
1821 Saratoga Ave., Suite 250  
Saratoga, CA 95070  
USA  
Tel: +1 408 366-8225  
Fax: +1 408 366-8220

**Shenzhen:**

**Elan Microelectronics Shenzhen, Ltd.**  
3F, SSMEC Bldg., Gaoxin S. Ave. I  
Shenzhen Hi-Tech Industrial Park  
(South Area) Shenzhen, 518057  
CHINA  
Tel: +86 755 2601-0565  
Fax: +86 755 2601-0500

**Shanghai:**

**Elan Microelectronics Shanghai, Ltd.**  
23/Bldg. #115 Lane 572, Bibo Road  
Zhangjiang Hi-Tech Park  
Shanghai, CHINA  
Tel: +86 21 5080-3866  
Fax: +86 21 5080-4600

# Contents

<b>1</b>	<b>General Description</b> .....	<b>1</b>
<b>2</b>	<b>Features</b> .....	<b>1</b>
<b>3</b>	<b>Pin Assignment</b> .....	<b>2</b>
<b>4</b>	<b>Pin Description</b> .....	<b>6</b>
<b>5</b>	<b>Functional Block Diagram</b> .....	<b>10</b>
<b>6</b>	<b>Function Description</b> .....	<b>11</b>
6.1	Register Configuration .....	11
6.1.1	R PAGE Register Configuration .....	11
6.2	Register Operations .....	11
6.2.1	R0 (Indirect Addressing Register).....	11
6.2.2	R1 (TCC) .....	11
6.2.3	R2 (Program Counter) .....	12
6.2.4	R3 (LVD Control, Status) .....	13
6.2.5	R4 (RAM Select Register) .....	14
6.2.6	Bank 0 R5 (RAM Bank Select Register).....	14
6.2.7	Bank 0 R7 (Port 7).....	14
6.2.8	Bank 0 R8 (Port 8).....	14
6.2.9	Bank 0 R9 (Port 9).....	15
6.2.10	Bank 0 RA (Port A).....	15
6.2.11	Bank 0 RB (Port B) .....	15
6.2.12	Bank 0 RC SCCR (System Clock Control Register) .....	15
6.2.13	Bank 0 RD TWTCR (TCC and WDT Timer Control Register) .....	16
6.2.14	Bank 0 RE IMR (Interrupt Mask Register).....	17
6.2.15	Bank 0 RF ISR (Interrupt Status Register) .....	17
6.2.16	Bank 1 R5 LCDCR (LCD Control Register).....	18
6.2.17	Bank 1 R6 LCDAR (LCD Address Register) .....	18
6.2.18	Bank 1 R7 LCDBR (LCD Data Buffer).....	19
6.2.19	Bank 1 R8 LCDVCR (LCD Voltage Control Register) .....	19
6.2.20	Bank 1 R9 LCDCCR (LCD Com Control Register 3) .....	20
6.2.21	Bank 1 RA LCDSCR0 (LCD Segment Control Register 0).....	20
6.2.22	Bank 1 RB LCDSCR1 (LCD Segment Control Register 1) .....	20
6.2.23	Bank 1 RC LCDSCR2 (LCD Segment Control Register 2) .....	21
6.2.24	Bank 1 RE EIMR (External Interrupt Mask Register) .....	21
6.2.25	Bank 1 RF EISR (External Interrupt Status Register).....	21
6.2.26	Bank 2 R5 T1CR (Timer1 Control Register).....	22
6.2.27	Bank 2 R6 TSR (Timer Status Register).....	23
6.2.28	Bank 2 R7 T1PD (Timer1 Period Buffer) .....	24
6.2.29	Bank 2 R8 T1TD (Timer 1 Duty Buffer) .....	24
6.2.30	Bank 2 R9 T2CR (Timer 2 Control Register).....	24



6.2.31	Bank 2 RA T2PD (Timer 2 Period Buffer)	25
6.2.32	Bank 2 RB T2TD (Timer 2 Duty Buffer)	25
6.2.33	Bank 2 RC SPIS (SPI Status Register)	25
6.2.34	Bank 2 RD SPIC (SPI Control Register)	26
6.2.35	Bank 2 RE SPIR (SPI Read Buffer)	27
6.2.36	Bank 2 RF SPIW (SPI Write Buffer)	27
6.2.37	Bank 3 R5 URC (UART Control Register)	28
6.2.38	Bank 3 R6 URS (UART Status)	29
6.2.39	Bank 3 R7 URRD (UART_RD Data Buffer)	29
6.2.40	Bank 3 R8 URTD (UART_TD Data Buffer)	30
6.2.41	Bank 3 R9 ADCR (A/D Control Register)	30
6.2.42	Bank 3 RA ADICH (A/D Input Control Register)	31
6.2.43	Bank 3 RB ADICL (A/D Input Control Register)	31
6.2.44	Bank 3 RC ADDH (AD High 8-bit Data Buffer)	31
6.2.45	Bank 3 RD ADDL (AD Low 4-bit Data Buffer)	31
6.2.46	Bank 3 RE EIESH (External Interrupt Edge Select High Byte Control Register)	32
6.2.47	Bank 3 RF EIESL (External Interrupt Edge Select Low Byte Control Register)	32
6.2.48	Bank 4 R5 LEDDCR (LED Drive Control Register)	33
6.2.49	Bank 4 R6 WBCR (Watchdogdog Timer and Buzzer Control Register)	33
6.2.50	Bank 4 R7 PIOCRA (Port 7 I/O Control Register)	34
6.2.51	Bank 4 R8 PIOCRA (Port 8 I/O Control Register)	34
6.2.52	Bank 4 R9 PIOCRA (Port 9 I/O Control Register)	34
6.2.53	Bank 4 RA PIOCRA (Port A I/O Control Register)	34
6.2.54	Bank 4 RB PIOCRA (Port B I/O Control Register)	35
6.2.55	Bank 4 RC PIOCRA (Port C I/O Control Register)	35
6.2.56	Bank 4 RF WKCR (Wake-up Control Register)	35
6.2.57	Bank 5 R6 UARC2 (UART Control Register 2)	35
6.2.58	Bank 5 R7 P7PHCR (Port 7 Pull High Control Register)	36
6.2.59	Bank 5 R8 P8PHCR (Port 8 Pull High Control Register)	36
6.2.60	Bank 5 R9 P9PHCR (Port 9 Pull-high Control Register)	36
6.2.61	Bank 5 RA PAPHCR (Port A Pull-high Control Register)	36
6.2.62	Bank 5 RB PBPHCR (Port B Pull-high Control Register)	37
6.2.63	Bank 5 RC PCPHCR (Port C Pull High Control Register)	37
6.2.64	Bank 6 R6 LVRCR (Low Voltage Reset Control Register)	37
6.2.65	Bank 6 R7 P7ODCR (Port 7 Open Drain Control Register)	37
6.2.66	Bank 6 R8 P8ODCR (Port 8 Open Drain Control Register)	38
6.2.67	Bank 6 R9 P9ODCR (Port 9 Open Drain Control Register)	38
6.2.68	Bank 6 RA PAODCR (Port A Open Drain Control Register)	38
6.2.69	Bank 6 RB PBODCR (Port B Open Drain Control Register)	38
6.2.70	Bank 6 RC (Port C)	38
6.2.71	R10~R3F (General Purpose Register)	38
6.3	TCC/WDT Pre-scaler	39



6.4	I/O Port.....	40
6.5	Reset and Wake-up .....	41
6.6	Oscillator .....	51
6.6.1	Oscillator Modes.....	51
6.6.2	Crystal Oscillator/Ceramic Resonators (Crystal).....	51
6.6.3	RC Oscillator Mode with Internal Capacitor .....	53
6.6.4	Phase Lock Loop (PLL Mode) .....	54
6.7	Power-on Considerations .....	55
6.7.1	External Power-on Reset Circuit .....	55
6.7.2	Residue-Voltage Protection .....	56
6.8	Interrupt.....	57
6.9	LCD Driver .....	58
6.9.1	R5 LCDCR (LCD Control Register).....	59
6.9.2	R6 LCDADDR (LCD Address Register) .....	60
6.9.3	R7 LCDBR (LCD Data Buffer).....	61
6.9.4	R8 LCDVCR (LCD Voltage Control Register) .....	61
6.10	A/D Converter .....	69
6.10.1	ADC Data Register .....	70
6.10.2	A/D Sampling Time .....	70
6.10.3	A/D Conversion Time.....	70
6.11	UART (Universal Asynchronous Receiver/Transmitter).....	71
6.11.1	UART Mode .....	72
6.11.2	Transmitting .....	73
6.11.3	Receiving .....	73
6.11.4	Baud Rate Generator .....	74
6.11.5	UART Timing.....	74
6.12	SPI (Serial Peripheral Interface).....	75
6.12.1	Overview & Features .....	75
6.12.2	SPI Function Description .....	77
6.12.3	SPI Signal & Pin Description .....	78
6.12.4	Programming the Related Registers .....	80
6.12.5	SPI Mode Timing .....	83
6.13	Timer/Counter 1 .....	84
6.13.1	Timer Mode.....	85
6.13.2	T1OUT Mode .....	85
6.13.3	Capture Mode .....	85
6.13.4	PWM Mode .....	86
6.13.5	16-Bit Mode .....	86
6.14	Timer 2 .....	87
6.14.1	Timer Mode.....	88
6.14.2	PWM Mode .....	88
6.15	Code Options .....	89
6.16	Instruction Set.....	91



<b>7</b>	<b>Absolute Maximum Ratings .....</b>	<b>94</b>
<b>8</b>	<b>DC Electrical Characteristics .....</b>	<b>94</b>
8.1	DC Electrical Characteristics .....	94
8.2	A/D Converter Characteristic .....	96
8.3	Phase Lock Loop Characteristic .....	97
8.3.1	PLL DC Electrical Characteristic .....	97
8.3.2	AC Electrical Characteristic .....	97
8.4	Device Characteristic .....	97
<b>9</b>	<b>AC Electrical Characteristics .....</b>	<b>107</b>
<b>10</b>	<b>Timing Diagrams .....</b>	<b>108</b>

## APPENDIX

<b>A</b>	<b>Package Type .....</b>	<b>109</b>
<b>B</b>	<b>Package Information .....</b>	<b>110</b>
B.1	48-Lead Low Profile Quad Flat Package (LQFP) .....	110
B.2	44-Lead Low Profile Quad Flat Package (LQFP) .....	111
B.3	44-Lead Quad Flat Package (QFP) .....	112
B.4	42-Lead Dual Inline Package (DIP) .....	113
B.5	32-Lead Shrink Dual Inline Package (SDIP) .....	114
B.6	32-Lead Small Outline Package (SOP) .....	115
<b>C</b>	<b>Quality Assurance and Reliability .....</b>	<b>116</b>
C.1	Address Trap Detect .....	116
<b>D</b>	<b>EM78P510N Program Pin List .....</b>	<b>117</b>
<b>E</b>	<b>ICE 510 Oscillator circuit (JP4) .....</b>	<b>117</b>
E.1	Mode 1 .....	117
E.2	Mode2 .....	118
E.3	Mode3 .....	118
E.4	Mode4 .....	118
E.5	Mode5 .....	119
E.6	Mode6 .....	119
E.7	Mode7 .....	119
<b>F</b>	<b>ICE 510 Output Pin Assignment (JP 3) .....</b>	<b>120</b>

## Specification Revision History

Doc. Version	Revision Description	Date
1.0	Initial released version	2007/03/16



## 1 General Description

The EM78P510N is an 8-bit RISC type microprocessor with low power, high speed CMOS technology. Integrated onto a single chip are on-chip Watchdog Timer (WDT), LCD Data RAM, ROM, programmable real time clock counter, internal/external interrupt, power down mode, 12 bits A/D Converter, UART, SPI, 8-channel LED driver, LCD driver and tri-state I/O.

## 2 Features

- CPU Configuration
  - 8K×13 bits on-chip ROM
  - 272×8 bits on-chip registers (SRAM)
  - 8 level stacks for subroutine nesting
  - Dual clock operation or PLL operation mode
  - Four operation mode: Normal, Green, Idle, Sleep
  - Four programmable Level Voltage Detector (LVD) : 3.9V, 3.3V, 2.7V, 2.4V
  - Four programmable Level Voltage Reset (LVR) : 3.9V, 3.3V, 2.6V, 2.1V(POR)
  - Less than 2.1 mA at 5V/4MHz
  - Typically 22  $\mu$ A, at 3V/32kHz
  - Typically 8  $\mu$ A, during sleep mode
  - 98% Single Instruction Cycle Commands
- I/O Port Configuration
  - 6 bi-directional I/O ports : P7, P8, P9, PA, PB, PC
  - 43 I/O pins
  - 8-pin Direct Drive LED
  - 39 Programmable open-drain I/O pins
  - 43 programmable pull-high I/O pins
  - External interrupt : P74~P77, PB0~PB3, P82~P83
- Operating voltage range:
  - OTP version:
    - Operating voltage range: 2.3V~5.5V
- Operating temperature range: -40~85°C
- Operating frequency range:
  - Crystal/RC oscillation circuit selected by code option for system clock
  - 32.768kHz crystal/RC oscillation circuit selected by code option for sub-oscillation
- Main Clock
  - Crystal mode:
    - DC ~ 20MHz/2clks @ 5V; DC ~100ns inst. cycle @ 5V
    - DC ~ 8MHz/2clks @ 3V; DC ~ 250ns inst. cycle @ 3V
    - DC ~ 4MHz/2clks @ 2.3V; DC ~ 500ns inst. cycle @ 2.3V
  - ERIC mode:
    - DC ~ 2.2MHz/2clks @ 2.3V; DC ~ 909ns inst. cycle @ 2.3V
  - PLL mode:
    - DC ~ 16MHz/2clks @ 5V; DC ~125ns inst. cycle @ 5V
    - DC ~ 8MHz/2clks @ 3V; DC ~ 250ns inst. cycle @ 3V
    - DC ~ 4MHz/2clks @ 2.3V; DC ~ 500ns inst. cycle @ 2.3V
- Sub Clock
  - Crystal mode: 32.768kHz
  - ERIC mode: 33kHz (2.2M $\Omega$ )
- Peripheral Configuration
  - Serial peripheral interface (SPI) available
  - 8-bit real time clock/counter (TCC)
  - 12-channels Analog-to-Digital Converter with 12-bit resolution in Vref mode
  - LCD: 8×23 dots, bias (1/2, 1/3, 1/4), duty (static, 1/3, 1/4, 1/8)
  - Two 8-bit timers
  - 8-bit Timer 1, auto reload counter/timer which can be an interrupt source. Function mode; Timer, Toggle output, UART baud rate generator, Capture, PWM
  - 8-bit Timer 2, auto reload timer which can be an interrupt source. Function mode; Timer, SPI baud rate generator, PWM
  - Two sets of 8 bits auto reload counter/timer which can be cascaded to one 16-bit counter/timer
  - Universal asynchronous receiver / transmitter (UART) available
  - Four programmable watchdog timer: 1.0sec, 0.5sec, 0.25sec, 3.91ms
  - Four programmable buzzer output: 0.5kHz, 1kHz, 2kHz, 4kHz
- Eighteen available interrupts:
  - TCC overflow interrupt
  - Ten External interrupts (wake-up from sleep mode)
  - ADC completion interrupt
  - Two timer interrupt
  - Watchdog timer interrupt
  - Two serial I/O interrupt
  - Low voltage detect (LVD)
- Special Features
  - Programmable free running watchdog timer
  - High ESD immunity
  - High EFT immunity
  - Power saving Sleep mode
  - Selectable Oscillation mode
- Package types:
  - 48 pin LQFP 7×7mm : EM78P510NQS/J
  - 44 pin LQFP 10×10mm : EM78P510NAQS/J
  - 44 pin QFP 10×10mm : EM78P510NBQS/J
  - 42 pin DIP 600mil : EM78P510NPS/J
  - 32 pin SDIP 400mil : EM78P510NKS/J
  - 32 pin SDIP 400mil : EM78P510NAKS/J
  - 32 pin SOP 450mil : EM78P510NMS/J
  - 32 pin SOP 450mil : EM78P510NAMS/J

S/J: Green product do not contain hazardous substances

### 3 Pin Assignment

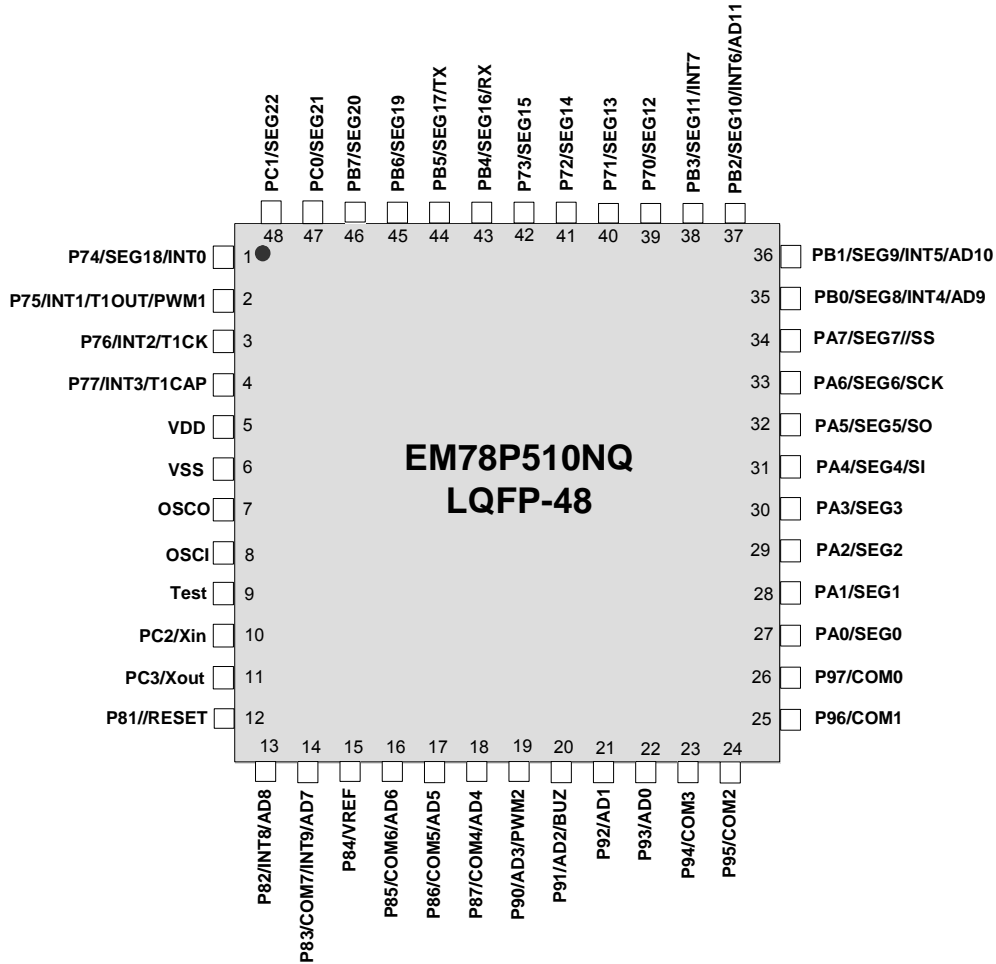

Figure 4-1a Pin Configuration for 48-pin LQFP Package

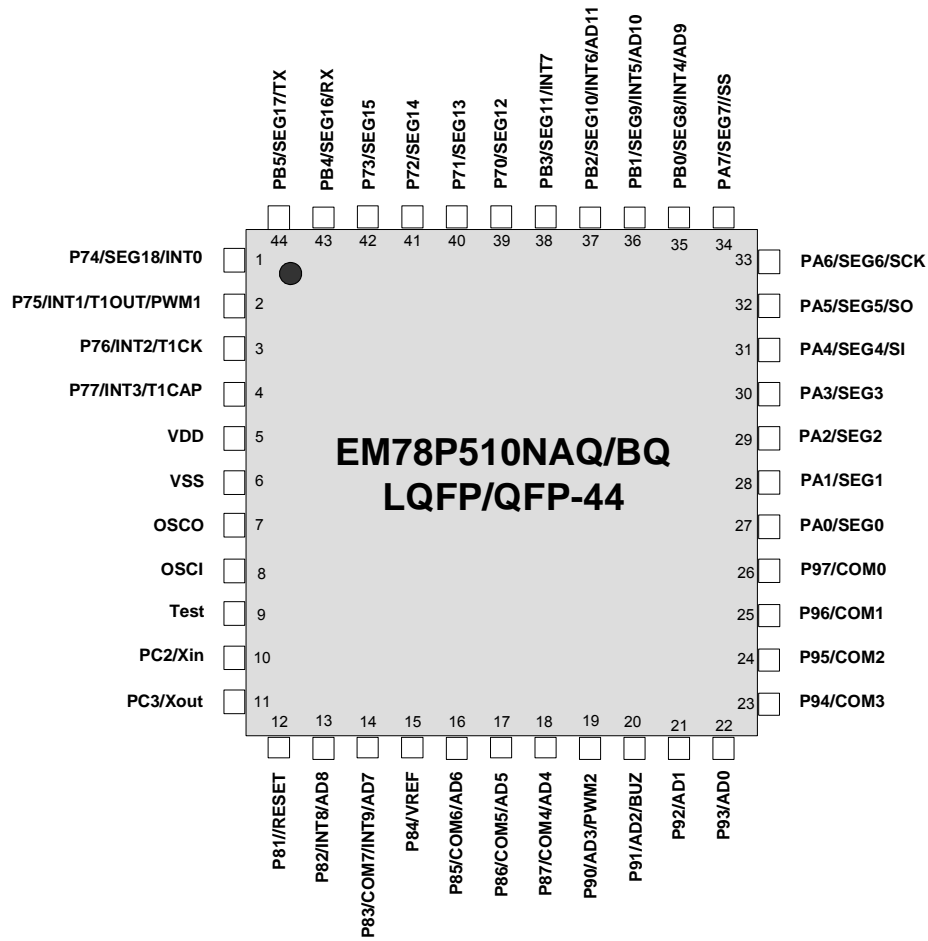

Figure 4-1b Pin Configuration for 44-pin LQFP/QFP Package

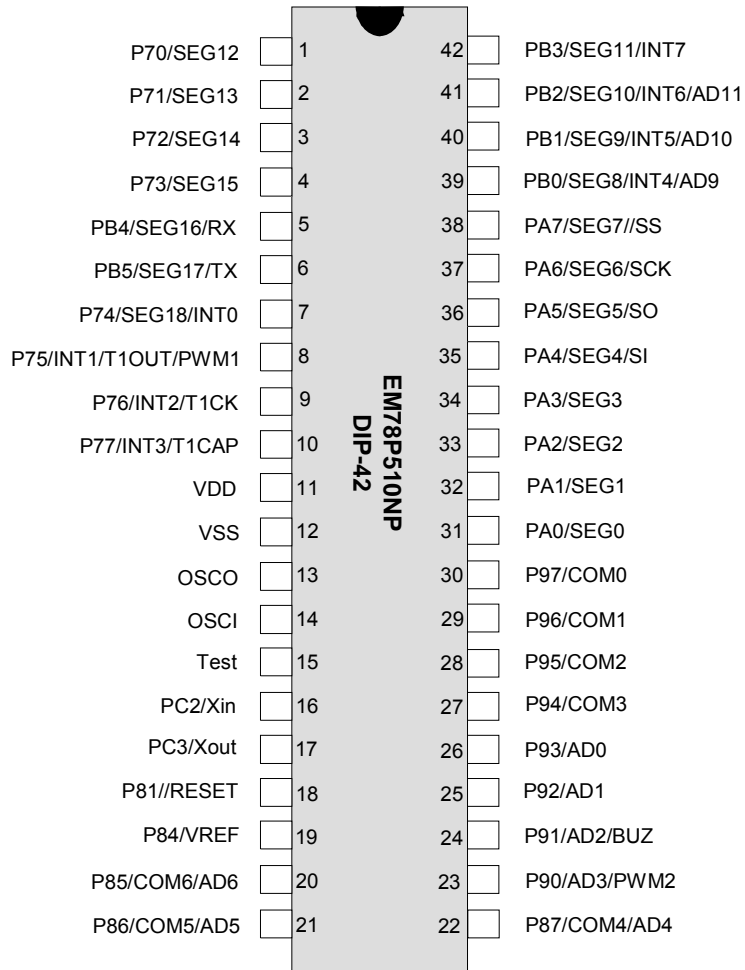

Figure 4-1c Pin Configuration for 42-pin DIP Package

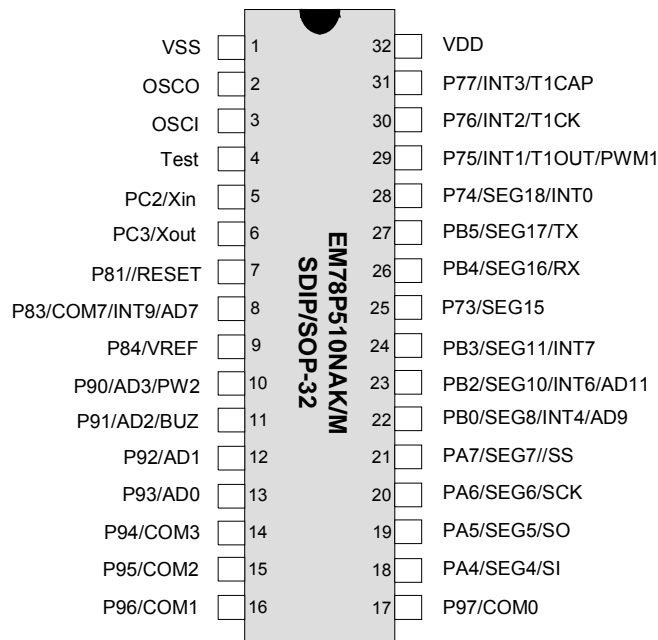
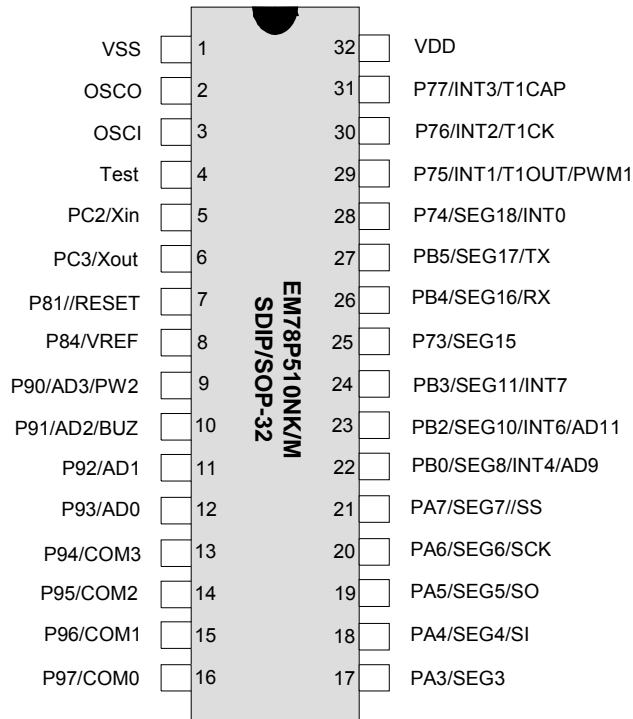

Figure 4-1d Pin Configuration for 32-pin Skinny SDIP / SOP Package

## 4 Pin Description

Table 1 (a) LQFP-48

Pin	Pin No.	I/O Type	Description
P70~P77	1~4, 39~42	I/O	8-bit bidirectional I/O pins. P70 ~ P73 are pin-shared with SEG12 ~ SEG15, respectively. P74 is pin-shared with external Interrupt 0 or SEG18. P75 is pin-shared with external Interrupt 1 or T1OUT or PWM1. P76 is pin-shared with external Interrupt 2 or T1CK. P77 is pin-shared with external Interrupt 3 or T1CAP.
P81~P87	12~18	I/O	7-bit bidirectional I/O pins. P81 is pin-shared with RESET pin. P82 is pin-shared with Interrupt 8 or AD8 input. P83 is pin-shared with COM7 or Interrupt 9 or AD7 input. P84 is pin-shared with A/D reference input pin. P85 is pin-shared with COM6 or AD6 input. P86 is pin-shared with COM5 or AD5 input. P87 is pin-shared with COM4 or AD4 input.
P90~P97	19~26	I/O	8-bit bidirectional I/O pins. P90 is pin-shared with AD3 input or PWM2. P91 is pin-shared with AD2 input or BUZ. P92 ~P93 are pin-shared with AD1 ~ AD0 input, respectively. P94 ~P97 are pin-shared with COM3 ~ COM0, respectively.
PA0~PA7	27~34	I/O	8-bit bidirectional I/O pins. PA0 ~ PA3 are pin-shared with SEG0 ~ SEG3, respectively. PA4 is pin-shared with SEG4 or SPI SI pin. PA5 is pin-shared with SEG5 or SPI SO pin. PA6 is pin-shared with SEG6 or SPI SCK pin. PA7 is pin-shared with SEG7 or SPI /SS pin.
PB0~PB7	35~38, 43~46	I/O	8-bit bidirectional I/O pins. PB0 is pin-shared with SEG8 or external Interrupt 4 or AD9 input. PB1 is pin-shared with SEG9 or external Interrupt 5 or AD10 input. PB2 is pin-shared with SEG10 or external Interrupt 6 or AD11 input. PB3 is pin-shared with SEG11 or external Interrupt 7. PB4 is pin-shared with SEG16 or UART RX pin. PB5 is pin-shared with SEG17 or UART TX pin. PB6 ~ PB7 are pin-shared with SEG19 ~ SEG20, respectively.
PC0~PC3	47~48 10~11	I/O	4-bit bidirectional I/O pins. PC0 ~ PC1 are pin-shared with SEG21 ~ SEG22, respectively. PC2 ~PC3 are pin-shared with Xin ~ Xout, respectively.
OSCI	8	I	Crystal mode: crystal input RC mode: pull-high resistor PLL mode: connect 0.01 $\mu$ F capacitance to GND. Connect 0.01 $\mu$ F capacitor to GND and code option select PLL mode when high oscillator is not used.
OSCO	7	O	Crystal mode: crystal output RC mode: instruction clock output PLL mode: instruction clock output
Test	9	I	Test signal import pin (must be connected to VDD)
Xin	10	I	Crystal mode: input pin for sub-oscillator. Connect to a 32.768kHz crystal. RC mode: pull-high resistor
Xout	11	O	In crystal mode: connect to a 32.768kHz crystal.
/RESET	12	I	Input pin with Schmitt Trigger. If this pin remains at logic low, the controller will also remain in rest condition.
VDD	5	I	Power supply pin
VSS	6	I	System ground pin



Table 1 (b) LQFP-44/QFP-44

Pin	Pin No.	I/O Type	Description
P70~P77	1~4, 39~42	I/O	8-bit bidirectional I/O pins. P70 ~ P73 are pin-shared with SEG12 ~ SEG15, respectively. P74 is pin-shared with external Interrupt 0 or SEG18. P75 is pin-shared with external Interrupt 1 or T1OUT or PWM1. P76 is pin-shared with external Interrupt 2 or T1CK. P77 is pin-shared with external Interrupt 3 or T1CAP.
P81~P87	12~18	I/O	7-bit bidirectional I/O pins. P81 is pin-shared with RESET pin. P82 is pin-shared with Interrupt 8 or AD8 input. P83 is pin-shared with COM7 or Interrupt 9 or AD7 input. P84 is pin-shared with A/D reference input pin. P85 is pin-shared with COM6 or AD6 input. P86 is pin-shared with COM5 or AD5 input. P87 is pin-shared with COM4 or AD4 input.
P90~P97	19~26	I/O	8-bit bidirectional I/O pins. P90 is pin-shared with AD3 input or PWM2. P91 is pin-shared with AD2 input or BUZ. P92 ~P93 are pin-shared with AD1 ~ AD0 input, respectively. P94 ~P97 are pin-shared with COM3 ~ COM0, respectively.
PA0~PA7	27~34	I/O	8-bit bidirectional I/O pins. PA0 ~ PA3 are pin-shared with SEG0 ~ SEG3, respectively. PA4 is pin-shared with SEG4 or SPI SI pin. PA5 is pin-shared with SEG5 or SPI SO pin. PA6 is pin-shared with SEG6 or SPI SCK pin. PA7 is pin-shared with SEG7 or SPI /SS pin.
PB0~PB5	35~38, 43~44	I/O	6-bit bidirectional I/O pins. PB0 is pin-shared with SEG8 or external Interrupt 4 or AD9 input. PB1 is pin-shared with SEG9 or external Interrupt 5 or AD10 input. PB2 is pin-shared with SEG10 or external Interrupt 6 or AD11 input. PB3 is pin-shared with SEG11 or external Interrupt 7. PB4 is pin-shared with SEG16 or UART RX pin. PB5 is pin-shared with SEG17 or UART TX pin.
PC2~PC3	10~11	I/O	2-bit bidirectional I/O pins. PC2 ~PC3 are pin-shared with Xin ~ Xout, respectively.
OSCI	8	I	Crystal mode: crystal input RC mode: pull-high resistor PLL mode: connect 0.01 $\mu$ F capacitance to GND. Connect 0.01 $\mu$ F capacitor to GND and code option select PLL mode when high oscillator is not used.
OSCO	7	O	Crystal mode: crystal output RC mode: instruction clock output PLL mode: instruction clock output
Test	9	I	Test signal import pin (must be connected to VDD)
Xin	10	I	Crystal mode: input pin for sub-oscillator. Connect to a 32.768kHz crystal. RC mode: pull-high resistor
Xout	11	O	Crystal mode: connect to a 32.768kHz crystal.
/RESET	12	I	Input pin with Schmitt Trigger. If this pin remains at logic low, the controller will also remain in reset condition.
VDD	5	I	Power supply pin
VSS	6	I	System ground pin



Table 1 (c) DIP-42

Pin	Pin No.	I/O Type	Description
P70~P77	1~4, 7~10	I/O	8-bit bidirectional I/O pins. P70 ~ P73 are pin-shared with SEG12 ~ SEG15, respectively. P74 is pin-shared with external Interrupt 0 or SEG18. P75 is pin-shared with external Interrupt 1 or T1OUT or PWM1. P76 is pin-shared with external Interrupt 2 or T1CK. P77 is pin-shared with external Interrupt 3 or T1CAP.
P81 P84~P87	18~22	I/O	5-bit bidirectional I/O pins. P81 is pin-shared with RESET pin. P84 is pin-shared with A/D reference input pin. P85 is pin-shared with COM6 or AD6 input. P86 is pin-shared with COM5 or AD5 input. P87 is pin-shared with COM4 or AD4 input.
P90~P97	23~30	I/O	8-bit bidirectional I/O pins. P90 is pin-shared with AD3 input or PWM2. P91 is pin-shared with AD2 input or BUZ. P92 ~P93 are pin-shared with AD1 ~ AD0 input, respectively. P94 ~P97 are pin-shared with COM3 ~ COM0, respectively.
PA0~PA7	31~38	I/O	8-bit bidirectional I/O pins. PA0 ~ PA3 are pin-shared with SEG0 ~ SEG3, respectively. PA4 is pin-shared with SEG4 or SPI SI pin. PA5 is pin-shared with SEG5 or SPI SO pin. PA6 is pin-shared with SEG6 or SPI SCK pin. PA7 is pin-shared with SEG7 or SPI /SS pin.
PB0~PB5	39~42, 5~6	I/O	6-bit bidirectional I/O pins. PB0 is pin-shared with SEG8 or external Interrupt 4 or AD9 input. PB1 is pin-shared with SEG9 or external Interrupt 5 or AD10 input. PB2 is pin-shared with SEG10 or external Interrupt 6 or AD11 input. PB3 is pin-shared with SEG11 or external Interrupt 7. PB4 is pin-shared with SEG16 or UART RX pin. PB5 is pin-shared with SEG17 or UART TX pin.
PC2~PC3	16~17	I/O	2-bit bidirectional I/O pins. PC2 ~PC3 are pin-shared with Xin ~ Xout, respectively.
OSCI	14	I	Crystal mode: crystal input RC mode: pull-high resistor PLL mode: connect 0.01 $\mu$ F capacitance to GND. Connect 0.01 $\mu$ F capacitor to GND and code option select PLL mode when high oscillator is not used.
OSCO	13	O	Crystal mode: crystal output RC mode: instruction clock output PLL mode: instruction clock output
Test	15	I	Test signal import pin (must be connected to VDD)
Xin	16	I	Crystal mode: input pin for sub-oscillator. Connect to a 32.768kHz crystal. RC mode: pull-high resistor
Xout	17	O	Crystal mode: connect to a 32.768kHz crystal.
/RESET	18	I	Input pin with Schmitt Trigger. If this pin remains at logic low, the controller will also remain in reset condition.
VDD	11	I	Power supply pin
VSS	12	I	System ground pin



Table 1 (d) SDIP-32/SOP-32

Pin	Pin No.	I/O Type	Description
P73, P74~P77	25, 28~31	I/O	5-bit bidirectional I/O pins. P73 is pin-shared with SEG15. P74 is pin-shared with external Interrupt 0 or SEG18. P75 is pin-shared with external Interrupt 1 or T1OUT or PWM1. P76 is pin-shared with external Interrupt 2 or T1CK. P77 is pin-shared with external Interrupt 3 or T1CAP.
P81, P84	7 8	I/O	2-bit bidirectional I/O pins. P81 is pin-shared with RESET pin. P83 can be used as COM7 or Interrupt 9 or AD7 input.(for EM78P510NAK/M use only) P84 is pin-shared with A/D reference input pin.
P90~P97	23~30	I/O	8-bit bidirectional I/O pins. P90 is pin-shared with AD3 input or PWM2. P91 is pin-shared with AD2 input or BUZ. P92 ~P93 are pin-shared with AD1 ~ AD0 input, respectively. P94 ~P97 are pin-shared with COM3 ~ COM0, respectively.
PA3~PA7	17~21	I/O	5-bit bidirectional I/O pins. PA3 is pin-shared with SEG3 (for EM78P510NK/M only) PA4 is pin-shared with SEG4 or SPI SI pin. PA5 is pin-shared with SEG5 or SPI SO pin. PA6 is pin-shared with SEG6 or SPI SCK pin. PA7 is pin-shared with SEG7 or SPI /SS pin.
PB0, PB2~PB5	22~24, 26~27	I/O	5-bit bidirectional I/O pins. PB0 is pin-shared with SEG8 or external Interrupt 4 or AD9 input. PB2 is pin-shared with SEG10 or external Interrupt 6 or AD11 input. PB3 is pin-shared with SEG11 or external Interrupt 7. PB4 is pin-shared with SEG16 or UART RX pin. PB5 is pin-shared with SEG17 or UART TX pin.
PC2~PC3	5~6	I/O	2-bit bidirectional I/O pins. PC2 ~PC3 are pin-shared with Xin ~ Xout, respectively.
OSCI	3	I	Crystal mode: crystal input RC mode: pull-high resistor PLL mode: connect 0.01 $\mu$ F capacitance to GND. Connect 0.01 $\mu$ F capacitor to GND and code option select PLL mode when high oscillator is not used.
OSCO	2	O	Crystal mode: crystal output RC mode: instruction clock output PLL mode: instruction clock output
Test	45	I	Test signal import pin (must be connected to VDD)
Xin	5	I	Crystal mode: input pin for sub-oscillator. Connect to a 32.768kHz crystal. RC mode: pull-high resistor
Xout	6	O	Crystal mode: connect to a 32.768kHz crystal.
/RESET	7	I	Input pin with Schmitt Trigger. If this pin remains at logic low, the controller will also remain in reset condition.
VDD	32	I	Power supply pin
VSS	1	I	System ground pin

**Note:** When use common pin IO and LCD (P70~74, P83, P85~87, P94~97, PA0~A7, PB0~B7 and PC0~C1), it is recommended to use circuit sink.

## 5 Functional Block Diagram

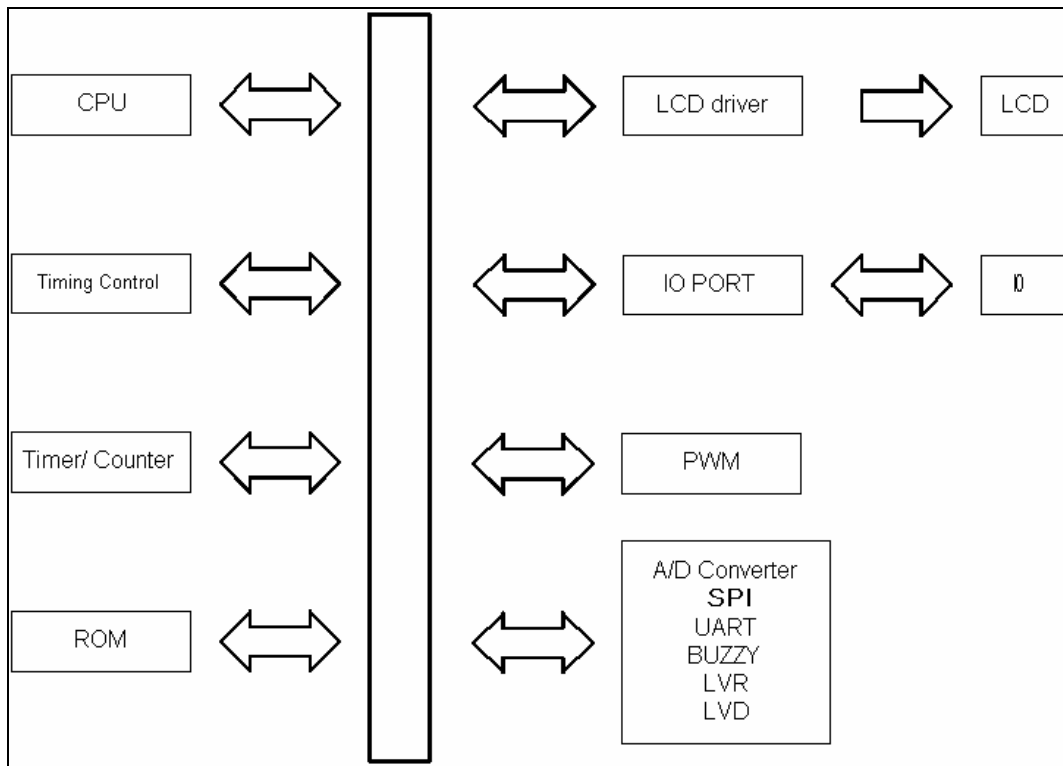

Figure 5-1a EM78P510N Block Diagram (Overview)

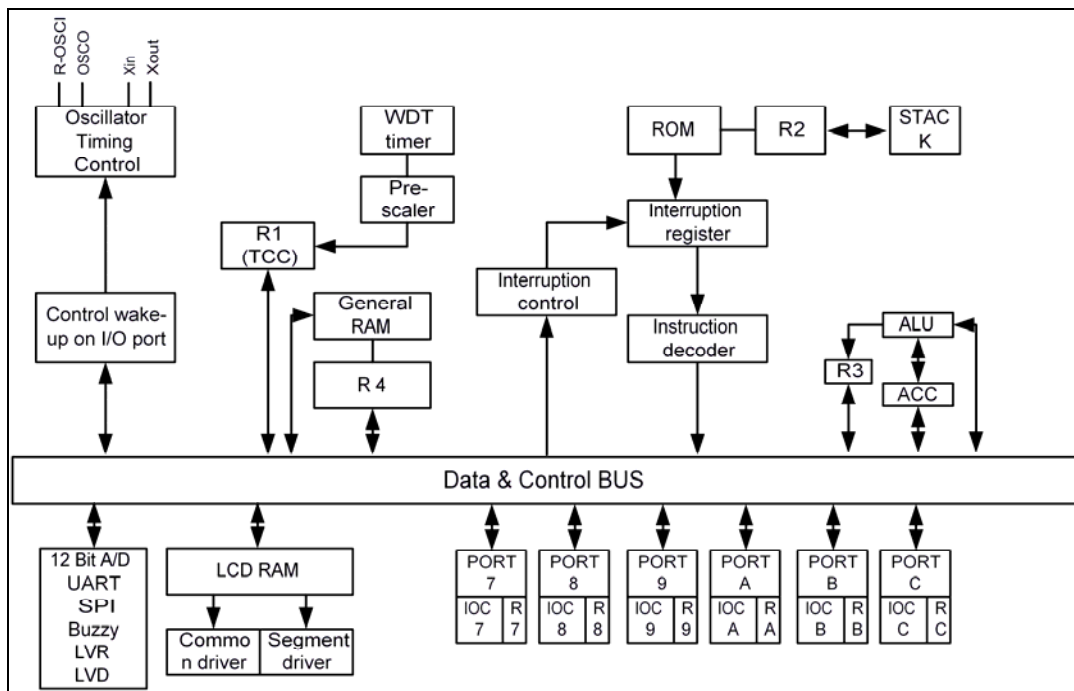

Figure 5-1b EM78P510N Block Diagram (Detailed)



## 6 Function Description

### 6.1 Register Configuration

#### 6.1.1 R PAGE Register Configuration

Bank 0	Bank 1	Bank 2	Bank 3	Bank 4	Bank 5	Bank 6
R0 (IAR)						
R1 (TCC)						
R2 (PC)						
R3 (SR)						
R4 (RSR)						
RBSR	LCDCR	T1CR	URC	LEDDCR		
RPSR	LCDAR	TSR	URS	WBCR	URC2	LVR CR
PORT7	LCDBR	T1PD	URRD	IOC7	P7PHCR	P7ODCR
PORT8	LCDVCR	T1TD	URTD	IOC8	P8PHCR	P8ODCR
PORT9	LCDCR	T2CR	ADCR	IOC9	P9PHCR	P9ODCR
PORTA	LCDSCR0	T2PD	ADICH	IOCA	PAPHCR	PAODCR
PORTB	LCDSCR1	T2TD	ADICL	IOCB	PBPHCR	PBODCR
SCCR	LCDSCR2	SPI S	ADDH	IOCC	PCPHCR	PORTC
TWTCR		SPIC	ADDL			
IMR	EIMR	SPIR	EIESH			
ISR	EISR	SPIW	EIESL	WKCR		
R10						
.						
.						
R1F						
R20	General Purpose RAM					R20
.	.	.				.
.	.	.				.
.	.	.				.
R3F	.	.				R3F

Figure 6-1 Data Memory Configuration

### 6.2 Register Operations

#### 6.2.1 R0 (Indirect Addressing Register)

R0 is not a physically implemented register. It is used as an indirect addressing pointer. Any instruction using R0 as register actually accesses data pointed by the RAM Select Register (R4).

#### 6.2.2 R1 (TCC)

Incremented by the main oscillator clock (Fm) or sub oscillator clock (Fs) (controlled by TWTCR register). Written and read by the program as any other register.

### 6.2.3 R2 (Program Counter)

The structure is depicted in Fig. 6-2. Generates  $8K \times 13$  on-chip ROM addresses to the relative programming instruction codes.

"JMP" instruction allows the direct loading of the low 10 program counter bits.

"CALL" instruction loads the low 10 bits of the PC and PC+1, and then push into the stack.

"RET" ("RETL k", "RETI") instruction loads the program counter with the contents at the top of stack.

"MOV R2, A" allows the loading of an address from the A register to the PC, and contents of the ninth and tenth bits don't change.

"ADD R2, A" allows a relative address be added to the current PC, and contents of the ninth and tenth bits don't change.

The most significant bit (A10~A11) will be loaded with the contents of Bit PS0~PS2 in the status register (R6) upon the execution of a "JMP", "CALL" instruction.

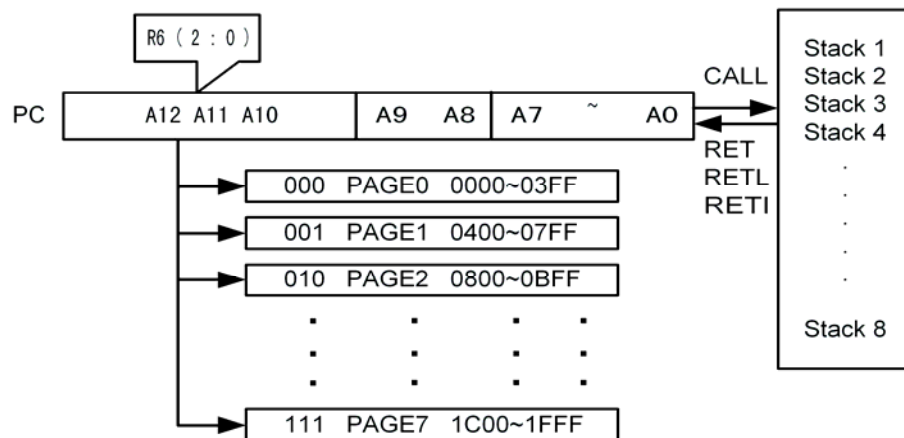

Figure 6-2 Program Counter Organization

User can use Long jump (LJMP) or long call (LCALL) instructions to program user's code. And the program page is maintained by ELAN's compiler. It will change user's program by inserting instructions within the program.

### 6.2.4 R3 (LVD Control, Status)

■ Status Flag, Page Selection Bits

Bit 7	Bit 6	Bit 5	Bit 4	Bit 3	Bit 2	Bit 1	Bit 0
LV DEN	LV DS1	LV DS0	T	P	Z	DC	C

**Bit 7 (LV DEN):** Voltage Detect Enable Bit

0 : No action

1 : Voltage detect enabled

**Bits 6~5 (LV DS1~LV DS0):** Detect Voltage Select Bits

LV DS1	LV DS0	Detect Voltage
0	0	2.4V
0	1	2.7V
1	0	3.3V
1	1	3.9V

**Bit 4 (T):** Time-out bit

Set to 1 by the "SLEP" and "WDTC" command, or during power up and reset to 0 by WDT timeout.

**Bit 3 (P):** Power down bit

Set to "1" during power on or by a "WDTC" command and reset to "0" by a "SLEP" command.

Event	T	P	Remarks
WDT wakes up from sleep mode	0	0	
WDT times out (not in sleep mode)	0	1	
/RESET wakes up from sleep	1	0	
Power up	1	1	
Low pulse on /RESET	×	×	× = don't care

**Bit 2 (Z):** Zero flag

**Bit 1 (DC):** Auxiliary carry flag

**Bit 0 (C):** Carry flag



### 6.2.5 R4 (RAM Select Register)

**Bit 7 (VDB):** Voltage Detector. This is a read only bit. When VDD pin voltage is lower than Vdet (select by LVDS0~LVDS1) this bit will be cleared.

**0 :** low voltage is detected

**1 :** low voltage is not detected or LVD function is disabled

**Bit 6 (BNC):** Bank Control Register.

**0 :** allow to access only Bank 0 registers

**1 :** Allow to access all registers of any Bank

**Bits 5~0:** are used to select up to 64 registers in the indirect addressing mode.

See the configuration of the data memory. User can use BANK instruction to change bank.

### 6.2.6 Bank 0 R5 (RAM Bank Select Register)

Bit 7	Bit 6	Bit 5	Bit 4	Bit 3	Bit 2	Bit 1	Bit 0
0	0	0	0	0	BS2	BS1	BS0

**Bits 7~3:** Reserved

**Bits 2~0 (BS2~BS0):** RAM Bank Select Register

BS2	BS1	BS0	RAM Bank
0	0	0	Bank 0
0	0	1	Bank 1
:	:	:	:
:	:	:	:
1	1	1	Bank 7

### 6.2.7 Bank 0 R7 (Port 7)

Bit 7	Bit 6	Bit 5	Bit 4	Bit 3	Bit 2	Bit 1	Bit 0
R77	R76	R75	R74	R73	R72	R71	R70

**Bits 7~0 (R77~R70):** Port 7 8-bit I/O Registers.

### 6.2.8 Bank 0 R8 (Port 8)

Bit 7	Bit 6	Bit 5	Bit 4	Bit 3	Bit 2	Bit 1	Bit 0
R87	R86	R85	R84	R83	R82	R81	0

**Bits 7~1 (R87~R81):** Port 8 7-bit I/O Registers.

**Bit 0:** Reserved

### 6.2.9 Bank 0 R9 (Port 9)

Bit 7	Bit 6	Bit 5	Bit 4	Bit 3	Bit 2	Bit 1	Bit 0
R97	R96	R95	R94	R93	R92	R91	R90

Bits 7~0 (R97~R90): Port 9 8-bit I/O Registers.

### 6.2.10 Bank 0 RA (Port A)

Bit 7	Bit 6	Bit 5	Bit 4	Bit 3	Bit 2	Bit 1	Bit 0
RA7	RA6	RA5	RA4	RA3	RA2	RA1	RA0

Bits 7~0 (RA7~RA0): Port A 8-bit I/O Registers

### 6.2.11 Bank 0 RB (Port B)

Bit 7	Bit 6	Bit 5	Bit 4	Bit 3	Bit 2	Bit 1	Bit 0
RB7	RB6	RB5	RB4	RB3	RB2	RB1	RB0

Bits 7~0 (RB7~RB0): Port B 8-bit I/O Registers

### 6.2.12 Bank 0 RC SCCR (System Clock Control Register)

Bit 7	Bit 6	Bit 5	Bit 4	Bit 3	Bit 2	Bit 1	Bit 0
0	CLK2	CLK1	CLK0	IDLE	0	0	CPUS

Bit 7: Reserved, fixed to "0"

Bits 6~4 (CLK2~CLK0): Main Clock Select Bit for PLL Mode (code option select)

CLK2	CLK1	CLK0	Main Clock	Ex: $F_s=32.768K$
0	0	0	$F_s \times 122$	3.997 MHz
0	0	1	$F_s \times 61$	1.998 MHz
0	1	0	$F_s \times 61/2$	0.999 MHz (default)
0	1	1	$F_s \times 61/4$	499.7 kHz
1	0	0	$F_s \times 244$	7.995 MHz
1	0	1	$F_s \times 366$	11.99 MHz
1	1	×	$F_s \times 488$	15.99 MHz

Bit 3 (IDLE): Idle Mode Enable Bit. This bit will decide SLEP instruction which mode to go.

IDLE="0"+SLEP instruction → sleep mode

IDLE="1"+SLEP instruction → idle mode

Bits 2~1: Reserved, fixed to "0"

Bit 0 (CPUS): CPU Oscillator Source Select, 0/1 → sub-oscillator (fs)/ main oscillator (fosc) When CPUS=0, the CPU oscillator select sub-oscillator and the main oscillator is stopped.

CPU Operation Mode

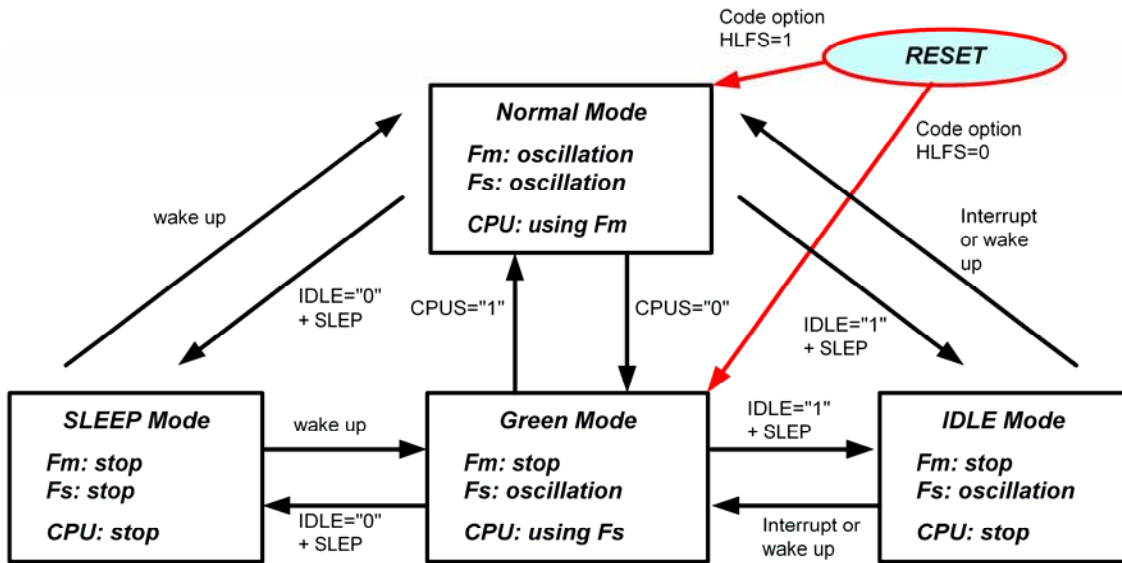

Figure 6-3 CPU operation mode

6.2.13 Bank 0 RD TWTCR (TCC and WDT Timer Control Register)

Bit 7	Bit 6	Bit 5	Bit 4	Bit 3	Bit 2	Bit 1	Bit 0
WDTE	WPSR2	WPSR1	WPSR0	TCCS	TPSR2	TPSR1	TPSR0

**Bit 7 (WDTE):** Watchdog Timer Enable. This control bit is used to enable the watchdog timer.

- 0 : Disable WDT function
- 1 : Enable WDT function

**Bits 6~4 (WPSR2~WPSR0):** WDT Prescaler Bits

WPSR2	WPSR1	WPSR0	Prescaler
0	0	0	1:1 (Default)
0	0	1	1 : 2
0	1	0	1 : 4
0	1	1	1 : 8
1	0	0	1 : 16
1	0	1	1 : 32
1	1	0	1 : 64
1	1	1	1 : 128

**Bit 3 (TCCS):** TCC Clock Source Select Bit

- 0 : Fm (main clock).
- 1 : Fs (sub clock: 32.768kHz)

**Bits 2~0 (TPSR2~TPSR0): TCC Prescaler Bits**

TPSR2	TPSR1	TPSR0	Prescaler
0	0	0	1:2 (Default)
0	0	1	1 : 4
0	1	0	1 : 8
0	1	1	1 : 16
1	0	0	1 : 32
1	0	1	1 : 64
1	1	0	1 : 128
1	1	1	1 : 256

### 6.2.14 Bank 0 RE IMR (Interrupt Mask Register)

Bit 7	Bit 6	Bit 5	Bit 4	Bit 3	Bit 2	Bit 1	Bit 0
T1IE	LVDIE	ADIE	SPIIE	URTIE	EXIE9	EXIE8	TCIE

**Bits 7~0 (T1IE~TCIE):** Interrupt Enable Bit. Enable interrupt source respectively.

**0** : Disable interrupt

**1** : Enable interrupt

#### External Interrupt

INT pin	Secondary function Pin	Enable Condition	Edge	Digital Noise Reject
INT8	P82, AD8	ENI+EXIE8(IMR1)	Rising or Falling	2/Fc
INT9	P83, COM7, AD7	ENI+EXIE9(IMR2)	Rising or Falling	2/Fc

**INT8~INT9:** Pulse less than 2/Fc is eliminated as noise. Pulse more than 4/Fc is as trigger signal.

### 6.2.15 Bank 0 RF ISR (Interrupt Status Register)

Bit 7	Bit 6	Bit 5	Bit 4	Bit 3	Bit 2	Bit 1	Bit 0
T1IF	LVDIF	ADIF	SPIIF	URTIF	EXIF9	EXIF8	TCIF

These bits are set to "1" when interrupt occurs respectively.

**Bit 7 (T1IF):** Interrupt Flag of Timer 1 Interrupt

**Bit 6 (LVDIF):** Interrupt Flag of Low Voltage Detector Interrupt

**Bit 5 (ADIF):** Interrupt Flag of A/D Convert Complete

**Bit 4 (SPIIF):** Interrupt Flag of SPI Transfer Complete

**Bit 3 (URTIF):** Interrupt Flag of UART Transmit Complete

**Bit 2 (EXIF9):** Interrupt Flag of External Interrupt 9 occurs

**Bit 1 (EXIF8):** Interrupt Flag of External Interrupt 8 occurs.

**Bit 0 (TCIF):** Interrupt Flag of TCC overflow



### 6.2.16 Bank 1 R5 LCDCR (LCD Control Register)

Bit 7	Bit 6	Bit 5	Bit 4	Bit 3	Bit 2	Bit 1	Bit 0
LCDEN	LCDTYPE	BS1	BS0	DS1	DS0	LCDF1	LCDF0

**Bit 7 (LCDEN):** LCD Enable Select Bit

- 0 : LCD disabled. All common/segment outputs are set to VDD level.
- 1 : LCD enabled

**Bit 6 (LCDTYPE):** LCD Drive Waveform Type Select Bit

- 0 : A type wave
- 1 : B type wave

**Bits 5~4 (BS1~BS0):** LCD Bias Select Bits

BS1	BS0	LCD Bias Select
0	0	1/2 Bias
0	1	1/3 Bias
1	×	1/4 Bias

**Bits 3~2 (DS1~DS0):** LCD Duty Select Bits

DS1	DS0	LCD Duty
0	0	Static
0	1	1/3 Duty
1	0	1/4 Duty
1	1	1/8 Duty

**Bits 1~0 (LCDF1~LCDF0):** LCD Frame Frequency Control Bits

LCD Frame Frequency (e.g. $F_s=32.768K$ )					
LCDF1	LCDF0	Static	1/3 Duty	1/4 Duty	1/8 Duty
0	0	$F_s/(512 \times 1) = 64.0$	$F_s/(172 \times 3) = 63.5$	$F_s/(128 \times 4) = 64$	$F_s/(64 \times 8) = 64.0$
0	1	$F_s/(560 \times 1) = 58.5$	$F_s/(188 \times 3) = 58$	$F_s/(140 \times 4) = 58.5$	$F_s/(70 \times 8) = 58.5$
1	0	$F_s/(608 \times 1) = 53.9$	$F_s/(204 \times 3) = 53.5$	$F_s/(152 \times 4) = 53.9$	$F_s/(76 \times 8) = 53.9$
1	1	$F_s/(464 \times 1) = 70.6$	$F_s/(156 \times 3) = 70$	$F_s/(116 \times 4) = 70.6$	$F_s/(58 \times 8) = 70.6$

### 6.2.17 Bank 1 R6 LCDAR (LCD Address Register)

Bit 7	Bit 6	Bit 5	Bit 4	Bit 3	Bit 2	Bit 1	Bit 0
0	0	0	LCD_A4	LCD_A3	LCD_A2	LCD_A1	LCD_A0

**Bits 7~5:** Reserved

**Bits 4~0 (LCD\_A4~LCD\_A0):** LCD RAM Address

R6 (LCD Address)	R7 (LCD Data Buffer)								Segment
	Bit 7 (LCD_D7)	Bit 6 (LCD_D6)	Bit 5 (LCD_D5)	Bit 4 (LCD_D4)	Bit 3 (LCD_D3)	Bit 2 (LCD_D2)	Bit 1 (LCD_D1)	Bit 0 (LCD_D0)	
00H									SEG0
01H									SEG1
02H									SEG2
14H									SEG20
15H									SEG21
16H									SEG22
Common	COM7	COM6	COM5	COM4	COM3	COM2	COM1	COM0	

### 6.2.18 Bank 1 R7 LCDBR (LCD Data Buffer)

Bit 7	Bit 6	Bit 5	Bit 4	Bit 3	Bit 2	Bit 1	Bit 0
LCD_D 7	LCD_D 6	LCD_D 5	LCD_D 4	LCD_D 3	LCD_D 2	LCD_D 1	LCD_D 0

Bit 7~0 (LCD\_D7~LCD\_D0): LCD RAM Data Transfer Register

### 6.2.19 Bank 1 R8 LCDVCR (LCD Voltage Control Register)

Bit 7	Bit 6	Bit 5	Bit 4	Bit 3	Bit 2	Bit 1	Bit 0
0	0	0	LCDC1	LCDC0	LCDVC2	LCDVC1	LCDVC0

Bits 7~5: Reserved

Bits 4~3 (LCDC1~LCDC0): LCD Clock

LCDC1	LCDC0	F <sub>m</sub>	F <sub>LCD</sub>
0	0	16M	F <sub>c</sub> /2 <sup>9</sup>
0	1	8M	F <sub>c</sub> /2 <sup>8</sup>
1	0	4M	F <sub>c</sub> /2 <sup>7</sup>
1	1	2M	F <sub>c</sub> /2 <sup>6</sup>

When the main oscillator operates in crystal mode and the sub-oscillator does not, it's a must to set these two bits for the LCD clock.



**Bits 2~0 (LCDVC2~LCDVC0): LCD Voltage Control Bits**

LCDVC2	LCDVC1	LCDVC0	Output
0	0	0	0.4VDD ~ VDD
0	0	1	0.34VDD ~ VDD
0	1	0	0.26VDD ~ VDD
0	1	1	0.18VDD ~ VDD
1	0	0	0.13VDD ~ VDD
1	0	1	0.07VDD ~ VDD
1	1	0	0.04VDD ~ VDD
1	1	1	0V ~ VDD

**6.2.20 Bank 1 R9 LCDCCR (LCD Com Control Register 3)**

Bit 7	Bit 6	Bit 5	Bit 4	Bit 3	Bit 2	Bit 1	Bit 0
COM7	COM6	COM5	COM4	COM3	COM2	COM1	COM0

**Bits 7~0 (COM7~COM0): LCD Com 7~0 Control Bits**

0 : Disable, functions as normal I/O or other functions

1 : Enable, functions as LCD common driver pins

**6.2.21 Bank 1 RA LCDSCR0 (LCD Segment Control Register 0)**

Bit 7	Bit 6	Bit 5	Bit 4	Bit 3	Bit 2	Bit 1	Bit 0
SEG7	SEG6	SEG5	SEG4	SEG3	SEG2	SEG1	SEG0

**Bits 7~0 (SEG7~SEG0): LCD Segments 7~0 Control Bits**

0 : Disable, functions as normal I/O or other functions

1 : Enable, functions as LCD common driver pins

**6.2.22 Bank 1 RB LCDSCR1 (LCD Segment Control Register 1)**

Bit 7	Bit 6	Bit 5	Bit 4	Bit 3	Bit 2	Bit 1	Bit 0
SEG15	SEG14	SEG13	SEG12	SEG11	SEG10	SEG9	SEG8

**Bits 7~0 (SEG15~SEG8): LCD Segments 15~8 Control Bits**

0 : Disable, functions as normal I/O or other functions

1 : Enable, functions as LCD common driver pins

### 6.2.23 Bank 1 RC LCDSCR2 (LCD Segment Control Register 2)

Bit 7	Bit 6	Bit 5	Bit 4	Bit 3	Bit 2	Bit 1	Bit 0
-	SEG22	SEG21	SEG20	SEG19	SEG18	SEG17	SEG16

**Bit 7:** Reserved

**Bits 6~0 (SEG22~SEG16):** LCD Segment 22~16 Control Bits

**0 :** Disable, functions as normal I/O or other functions

**1 :** Enable, functions as LCD common driver pins

### 6.2.24 Bank 1 RE EIMR (External Interrupt Mask Register)

Bit 7	Bit 6	Bit 5	Bit 4	Bit 3	Bit 2	Bit 1	Bit 0
EXIE7	EXIE6	EXIE5	EXIE4	EXIE3	EXIE2	EXIE1	EXIE0

**Bits 7~0 (EXIE7~EXIE0):** Interrupt Enable Bit. Enable interrupt source respectively.

**External interrupt**

INT Pin	Secondary Function Pin	Enable Condition	Edge	Digital Noise Reject
INT7	PB3, SEG11	ENI+EXIE7 (EIMR7)	Rising or Falling	2/Fc
INT6	PB2, SEG10, AD11	ENI+EXIE6 (EIMR6)	Rising or Falling	2/Fc
INT5	PB1, SEG9, AD10	ENI+EXIE5 (EIMR5)	Rising or Falling	2/Fc
INT4	PB0, SEG8, AD9	ENI+EXIE4 (EIMR4)	Rising or Falling	2/Fc
INT3	P77, T1CAP	ENI+EXIE3 (EIMR3)	Rising or Falling	2/Fc
INT2	P76, T1CK	ENI+EXIE2 (EIMR2)	Rising or Falling	2/Fc
INT1	P75, T1OUT, PWM1	ENI+EXIE1 (EIMR1)	Rising or Falling	2/Fc
INT0	P74, SEG18	ENI+EXIE0 (EIMR0)	Rising or Falling	2/Fc

**INT7~INT0:** Pulse less than 2/Fc is eliminated as noise. Pulse more than 4/Fc is as trigger signal.

### 6.2.25 Bank 1 RF EISR (External Interrupt Status Register)

Bit 7	Bit 6	Bit 5	Bit 4	Bit 3	Bit 2	Bit 1	Bit 0
EXIF7	EXIF6	EXIF5	EXIF4	EXIF3	EXIF2	EXIF1	EXIF0

These bits are set to "1" when interrupt occurs respectively.

**Bits 7~0 (EXIF7~EXIF0):** Interrupt Flag when External Interrupt 7~0 occur



### 6.2.26 Bank 2 R5 T1CR (Timer1 Control Register)

Bit 7	Bit 6	Bit 5	Bit 4	Bit 3	Bit 2	Bit 1	Bit 0
TIS1	TIS0	T1MS2	T1MS1	T1MS0	T1P2	T1P1	T1P0

**Bits 7~6 (TIS1~ TIS0):** Timer 1 and Timer 2 Interrupt Type Select Bits. These two bits are used when the Timer operates in PWM mode.

TIS1	TIS0	Timer 1 and Timer 2 Interrupt Type Select
0	0	TXPD underflow
0	1	TXTD underflow
1	X	TXPD and TXTD underflow

**Bits 5~3 (T1MS2~T1MS0):** Timer 1 Operation Mode Select Bits

T1MS2	T1MS1	T1MS0	Timer 1 Mode Select
0	0	0	Timer 1
0	0	1	T1OUT Mode
0	1	0	Capture Mode Rising Edge
0	1	1	Capture Mode Falling Edge
1	0	0	UART Baud Rate Generator
1	0	1	PWM 1
1	1	0	
1	1	1	

**Bits 2~0 (T1P2~T1P0):** Timer 1 Prescaler Bits

T1P2	T1P1	T1P0	Prescaler
0	0	0	1:2 (Default)
0	0	1	1 : 4
0	1	0	1 : 8
0	1	1	1 : 16
1	0	0	1 : 32
1	0	1	1 : 64
1	1	0	1 : 128
1	1	1	1 : 256

### 6.2.27 Bank 2 R6 TSR (Timer Status Register)

Bit 7	Bit 6	Bit 5	Bit 4	Bit 3	Bit 2	Bit 1	Bit 0
T1MOD	TRCB	T1CSS1	T1CSS0	T2CSS	T1S	T1OMS	T1OC

**Bit 7 (T1MOD):** Timer Operates Mode Select Bit

- 0 : Two 8-bit Timer
- 1 : Timer 1 and Timer 2 cascade to one 16-bit Timer

**NOTE**

*By setting T1MOD to "1", Timer can cascade to one 16-bit Timer. This 16 bits Timer is controlled by Time r1, including enable, clock source and prescaler. Timer 1 is MSB and Timer 2 is LSB in value of period and duty.*

**Bit 6 (TRCB):** Timers 1, 2 Read Control Bit

- 0 : When this bit set to 0, read data from T1PD or T2PD.
- 1 : When this bit set to 1, read data from T1PD or T2PD, but this is value of timer counter.

**Bits 5~4 (T1CSS1~T1CSS0):** Timer 1 Clock Source Select Bits

T1CSS1	T1CSS0	Timer 1 Clock Source Select
0	0	Fm
0	1	Fs
1	x	T1CK

**Bit 3 (T2CSS):** Timer 2 Clock Source Select Bit

- 0 : Main clock with prescaler
- 1 : Sub clock with prescaler

**Bit 2 (T1S):** Timer 1 Start Bit

- 0 : Timer 1 stop
- 1 : Timer 1 start

**Bit 1 (T1OMS):** Timer 1 Output Mode Select Bit

- 0 : Repeating mode
- 1 : One-shot mode

**NOTE**

*One-shot mode is only used in Timer 1, Capture and PWM1 modes.*



Mode Selected	Description
Timer 1	Down-counter wills underflow once and can't auto reload from T1PD.
Capture	In this mode, period and duty of the T1CAP input pin are measured once. This moment free running counter stop and can't detect a change of T1CAP edge.
PWM1	In this mode will generate one set of PWM1's duty and period, and then free running counter will stop.

**Bit 0 (T1OC):** Timer 1 Output Flip-Flop Control Bit

- 0 : T-FF is low
- 1 : T-FF is high

#### 6.2.28 Bank 2 R7 T1PD (Timer1 Period Buffer)

Bit 7	Bit 6	Bit 5	Bit 4	Bit 3	Bit 2	Bit 1	Bit 0
PRD1[7]	PRD1[6]	PRD1[5]	PRD1[4]	PRD1[3]	PRD1[2]	PRD1[1]	PRD1[0]

**Bits 7~0 (PRD1 [7]~PRD1 [0]):** The content of this register is a period of Timer 1.

#### 6.2.29 Bank 2 R8 T1TD (Timer 1 Duty Buffer)

Bit 7	Bit 6	Bit 5	Bit 4	Bit 3	Bit 2	Bit 1	Bit 0
TD1[7]	TD1[6]	TD1[5]	TD1[4]	TD1[3]	TD1[2]	TD1[1]	TD1[0]

**Bits 7~0 (TD1 [7]~TD1 [0]):** The content of this register is a duty of Timer 1.

#### 6.2.30 Bank 2 R9 T2CR (Timer 2 Control Register)

Bit 7	Bit 6	Bit 5	Bit 4	Bit 3	Bit 2	Bit 1	Bit 0
T2IF	T2IE	T2S	T2MS1	T2MS0	T2P2	T2P1	T2P0

**Bit 7 (T2IF):** Interrupt Flag of Timer 2 Interrupt

**Bit 6 (T2IE):** Timer 2 Interrupt Mask Bit

- 0 : Disable Timer 2 interrupt
- 1 : Enable Timer 2 interrupt

**Bit 5 (T2S):** Timer 2 Start Bit

- 0 : Timer 2 stop
- 1 : Timer 2 start

**Bits 4~3 (T2MS1~T2MS0):** Timer 2 Operation Mode Selects Bits

T2MS1	T2MS0	Timer 2 Mode Select
0	0	Timer 2
0	1	SPI Baud Rate Generator
1	0	PWM 2
1	1	

**Bits 2~0 (T2P2~T2P0):** Timer 2 Prescaler Bits

T2P2	T2P1	T2P0	Prescaler
0	0	0	1:2 (Default)
0	0	1	1 : 4
0	1	0	1 : 8
0	1	1	1 : 16
1	0	0	1 : 32
1	0	1	1 : 64
1	1	0	1 : 128
1	1	1	1 : 256

### 6.2.31 Bank 2 RA T2PD (Timer 2 Period Buffer)

Bit 7	Bit 6	Bit 5	Bit 4	Bit 3	Bit 2	Bit 1	Bit 0
PRD2[7]	PRD2[6]	PRD2[5]	PRD2[4]	PRD2[3]	PRD2[2]	PRD2[1]	PRD2[0]

**Bits 7~0 (PRD2 [7]~PRD2 [0]):** The content of this register is a period of Timer2.

### 6.2.32 Bank 2 RB T2TD (Timer 2 Duty Buffer)

Bit 7	Bit 6	Bit 5	Bit 4	Bit 3	Bit 2	Bit 1	Bit 0
TD2[7]	TD2[6]	TD2[5]	TD2[4]	TD2[3]	TD2[2]	TD2[1]	TD2[0]

**Bits 7~0 (TD2 [7]~TD2 [0]):** The contents of this register is a duty of Timer 2.

### 6.2.33 Bank 2 RC SPIS (SPI Status Register)

Bit 7	Bit 6	Bit 5	Bit 4	Bit 3	Bit 2	Bit 1	Bit 0
DORD	TD1	TD0	0	OD3	OD4	0	RBF

**Bit 7 (DORD):** Data Shift Control Bit

0 : Shift left (MSB first)

1 : Shift right (LSB first)



**Bits 6~5 (TD1~TD0):** SDO Status Output Delay Times Options

TD1	TD0	Delay Time
0	0	8 CLK
0	1	16 CLK
1	0	24 CLK
1	1	32 CLK

**Bit 4:** Reserved

**Bit 3 (OD3):** Open-Drain Control Bit

- 1 : Open-drain enable for SDO
- 0 : Open-drain disable for SDO

**Bit 2 (OD4):** Open-Drain Control bit

- 1 : Open-drain enable for SCK
- 0 : Open-drain disable for SCK

**Bit 1:** Reserved

**Bit 0 (RBF):** Read Buffer Full Flag

- 1 : Receiving completed, and SPIRB is fully exchanged.
- 0 : Receiving not completed, and SPIRB has not fully exchanged.

### 6.2.34 Bank 2 RD SPIC (SPI Control Register)

Bit 7	Bit 6	Bit 5	Bit 4	Bit 3	Bit 2	Bit 1	Bit 0
CES	SPIE	SRO	SSE	SDOC	SBRS2	SBRS1	SBRS0

**Bit 7 (CES):** Clock Edge Select Bit

- 0 : Data shift out on rising edge, and shifts in on falling edge. Data is on hold during low-level.
- 1 : Data shift out falling edge, and shift in on rising edge. Data is on hold during high-level.

**Bit 6 (SPIE):** SPI Enable Bit

- 0 : Disable SPI mode
- 1 : Enable SPI mode

**Bit 5 (SRO):** SPI Read Overflow Bit

- 0 : No overflow
- 1 : A new data is received while the previous data is still being held in the SPIRB register. In this situation, the data in SPIS register will be destroyed. To avoid setting this bit, user is required to read the SPIRB register although only the transmission is implemented. This can only occur in slave mode.



**Bit 4 (SSE):** SPI Shift Enable Bit

**0** : Reset as soon as the shift is complete, and the next byte is read to shift.

**1** : Start to shift, and remain on “1” while the current byte is still being transmitted.

**Bit 3 (SDOC):** SDO Output Status Control Bit

**0** : After the serial data output, the SDO remain high.

**1** : After the serial data output, the SDO remain low.

**Bits 2~0 (SBR2~SBR0):** SPI Baud Rate Select Bits

SBR2	SBR1	SBR0	Mode	SPI Baud Rate
0	0	0	Master	Fosc/2
0	0	1	Master	Fosc/4
0	1	0	Master	Fosc/8
0	1	1	Master	Fosc/16
1	0	0	Master	Fosc/32
1	0	1	Master	Timer2
1	1	0	Slave	/SS enable
1	1	1	Slave	/SS disable

### 6.2.35 Bank 2 RE SPIR (SPI Read Buffer)

Bit 7	Bit 6	Bit 5	Bit 4	Bit 3	Bit 2	Bit 1	Bit 0
SRB7	SRB6	SRB5	SRB4	SRB3	SRB2	SRB1	SRB0

**Bits 7~0 (SRB7~SRB0):** SPI Read Data Buffer

### 6.2.36 Bank 2 RF SPIW (SPI Write Buffer)

Bit 7	Bit 6	Bit 5	Bit 4	Bit 3	Bit 2	Bit 1	Bit 0
SWB7	SWB6	SWB5	SWB4	SWB3	SWB2	SWB1	SWB0

**Bits 7~0 (SWB7~SWB0):** SPI Write Data Buffer



### 6.2.37 Bank 3 R5 URC (UART Control Register)

Bit 7	Bit 6	Bit 5	Bit 4	Bit 3	Bit 2	Bit 1	Bit 0
URTD8	UMODE1	UMODE0	BRATE2	BRATE1	BRATE0	UTBE	TXE

**Bit 7 (URTD8):** Transmission Data Bit 8

**Bits 6~5 (UMODE1~UMODE0):** UART Transmission Mode Select Bit

UMODE1	UMODE0	UART Mode
0	0	Mode 1 : 7-Bit
0	1	Mode 2 : 8-Bit
1	0	Mode 3 : 9-Bit
1	1	Reserved

**Bits 4~2 (BRATE2~BRATE0):** Transmit Baud Rate Select ( $T_{uart}=F_c/16$ )

BRATE2	BRATE1	BRATE0	Baud Rate	e.g. $F_c = 8\text{MHz}$
0	0	0	$T_{uart}/13$	38400
0	0	1	$T_{uart}/26$	19200
0	1	0	$T_{uart}/52$	9600
0	1	1	$T_{uart}/104$	4800
1	0	0	$T_{uart}/208$	2400
1	0	1	$T_{uart}/416$	1200
1	1	0	Timer 1	
1	1	1	Reserved	

**Bit 1 (UTBE):** UART transfer buffer empty flag. Set to 1 when transfer buffer is empty. Reset to 0 automatically when writing to the URTD register. The UTBE bit will be cleared by hardware when transmission is enabled. The UTBE bit is read-only. Hence, writing to the URTD register is necessary to start transmit shifting.

**Bit 0 (TXE):** Enable transmission

**0 :** Disable

**1 :** Enable

### 6.2.38 Bank 3 R6 URS (UART Status)

Bit 7	Bit 6	Bit 5	Bit 4	Bit 3	Bit 2	Bit 1	Bit 0
URRD8	EVEN	PRE	PRERR	OVERR	FMERR	URBF	RXE

**Bit 7 (URRD8):** Receiving Data Bit 8

**Bit 6 (EVEN):** Select Parity Check

0 : Odd parity

1 : Even parity

**Bit 5 (PRE):** Enable Parity Addition

0 : Disable

1 : Enable

**Bit 4 (PRERR):** Parity Error Flag

Set to 1 when parity error occurs and cleared to 0 by software.

**Bit 3 (OVERR):** Over Running Error Flag

Set to 1 when overrun error occurs and cleared to 0 by software.

**Bit 2 (FMERR):** Framing Error Flag

Set to 1 when framing error occurs and cleared to 0 by software.

**Bit 1 (URBF):** UART Read Buffer Full Flag

Set to 1 when one character is received. Reset to 0 automatically when read from URS register. URBF will be cleared by hardware when enabling receiving. And URBF bit is read-only. Therefore, reading the URS register is necessary to avoid overrun error.

**Bit 0 (RXE):** Enable Receiving. It don't UART transmit interrupt.

0 : Disable

1 : Enable

### 6.2.39 Bank 3 R7 URRD (UART\_RD Data Buffer)

Bit 7	Bit 6	Bit 5	Bit 4	Bit 3	Bit 2	Bit 1	Bit 0
URRD7	URRD6	URRD5	URRD4	URRD3	URRD2	URRD1	URRD0

**Bits 7~0 (URRD7~URRD0):** UART Receive Data Buffer. Read only.



### 6.2.40 Bank 3 R8 URTD (UART\_TD Data Buffer)

Bit 7	Bit 6	Bit 5	Bit 4	Bit 3	Bit 2	Bit 1	Bit 0
URTD 7	URTD 6	URTD 5	URTD 4	URTD 3	URTD 2	URTD 1	URTD0

Bits 7~0 (URTD7~URTD0): UART Transmit Data Buffer. Write only.

### 6.2.41 Bank 3 R9 ADCR (A/D Control Register)

Bit 7	Bit 6	Bit 5	Bit 4	Bit 3	Bit 2	Bit 1	Bit 0
ADRUN	ADP	ADCK1	ADCK0	ADIS3	ADIS2	ADIS1	ADIS0

Bit 7 (ADRUN): AD Conversion Start

0 : Reset on completion of the conversion by hardware, this bit cannot be reset by software.

1 : Conversion starts

Bit 6 (ADP): A/D Power Control

Bits 5~4 (ADCK1~ADCK0): AD Converted Time Select Bits

ADCK1	ADCK0	Clock Source	Max. Operating Frequency (Fc)
0	0	Fc/4	1MHz
0	1	Fc/16	4MHz
1	0	Fc/32	8MHz
1	1	Fc/64	16MHz

Bits 3~0 (ADIS3~ADIS0): A/D Input Select Bits

ADIS3	ADIS2	ADIS1	ADIS0	Analog Input Pin
0	0	0	0	AD0
0	0	0	1	AD1
0	0	1	0	AD2
0	0	1	1	AD3
0	1	0	0	AD4
0	1	0	1	AD5
0	1	1	0	AD6
0	1	1	1	AD7
1	0	0	0	AD8
1	0	0	1	AD9
1	0	1	0	AD10
1	0	1	1	AD11

### 6.2.42 Bank 3 RA ADICH (A/D Input Control Register)

Bit 7	Bit 6	Bit 5	Bit 4	Bit 3	Bit 2	Bit 1	Bit 0
CALI	ADREF	0	0	ADE11	ADE10	ADE9	ADE8

**Bit 7 (CALI):** Calibration Enable Bit for A/D Offset

0 : disable Calibration

1 : enable Calibration

**Bit 6 (ADREF):** AD Reference Voltage Input Select

0 : Internal VDD, P84 is used as I/O.

1 : External reference pin, P84 is used as reference input pin.

External VREF is accuracy better than internal VDD.

**Bits 5~4:** Reserved

**Bits 3~0 (ADE11~ADE8):** AD Input Pin Enable Control

0 : Functions as I/O pin

1 : Functions as analog input pin

### 6.2.43 Bank 3 RB ADICL (A/D Input Control Register)

Bit 7	Bit 6	Bit 5	Bit 4	Bit 3	Bit 2	Bit 1	Bit 0
ADE7	ADE6	ADE5	ADE4	ADE3	ADE2	ADE1	ADE0

**Bits 7~0 (ADE7~ADE0):** AD input pin enable control.

0 : Functions as I/O pin

1 : Functions as analog input pin

### 6.2.44 Bank 3 RC ADDH (AD High 8-bit Data Buffer)

Bit 7	Bit 6	Bit 5	Bit 4	Bit 3	Bit 2	Bit 1	Bit 0
ADD11	ADD10	ADD9	ADD8	ADD7	ADD6	ADD5	ADD4

**Bits 7~0 (ADD11~ADD4):** AD High 8-Bit Data Buffer

### 6.2.45 Bank 3 RD ADDL (AD Low 4-bit Data Buffer)

Bit 7	Bit 6	Bit 5	Bit 4	Bit 3	Bit 2	Bit 1	Bit 0
SIGN	VOF[2]	VOF[1]	VOF[0]	ADD3	ADD2	ADD1	ADD0

**Bit 7 (SIGN):** Polarity Bit of Offset Voltage

0 : Negative voltage

1 : Positive voltage



**Bits 6~4 (VOF[2]~VOF[0]):** Offset Voltage Bits

VOF[2]	VOF[1]	VOF[0]	EM78P510N
0	0	0	0LSB
0	0	1	2LSB
0	1	0	4LSB
0	1	1	6LSB
1	0	0	8LSB
1	0	1	10LSB
1	1	0	12LSB
1	1	1	14LSB

**Bits 3~0 (ADD3~ADD0):** AD Low 4-Bit Data Buffer

#### 6.2.46 Bank 3 RE EIESH (External Interrupt Edge Select High Byte Control Register)

Bit 7	Bit 6	Bit 5	Bit 4	Bit 3	Bit 2	Bit 1	Bit 0
EIES7	EIES6	EIES5	EIES4	EIES3	EIES2	EIES1	EIES0

**Bits 7~0 (EIES7~EIES0):** External Interrupt 7~0 Edge Select Bit

0 : Falling edge interrupt

1 : Rising edge interrupt

#### 6.2.47 Bank 3 RF EIESL (External Interrupt Edge Select Low Byte Control Register)

Bit 7	Bit 6	Bit 5	Bit 4	Bit 3	Bit 2	Bit 1	Bit 0
0	0	0	ADWK	INTWK9	INTWK8	EIES9	EIES8

**Bits 7~5:** Reserved

**Bit 4 (ADWK):** A/D Converter Wake-up Function Enable Bit

0 : Disable

1 : Enable

**Bits 3~2 (INTWK9~INTWK8):** External Interrupt 9~8 Wake-up Function Enable Bit

0 : Disable

1 : Enable

**Bits 1~0 (EIES9~EIES8):** External Interrupt 9~8 Edge Select Bit

0 : Falling edges interrupt

1 : Rising edges interrupt



### 6.2.48 Bank 4 R5 LEDDCR (LED Drive Control Register)

Bit 7	Bit 6	Bit 5	Bit 4	Bit 3	Bit 2	Bit 1	Bit 0
LEDD7	LEDD6	LEDD5	LEDD4	LEDD3	LEDD2	LEDD1	LEDD0

**Bits 7~0 (LEDD7~LEDD0):** 8-bit LED Drive Control Registers

- 0 : Port 9 functions as normal I/O
- 1 : Port 9 functions as LED direct drive I/O

### 6.2.49 Bank 4 R6 WBCR (Watchdog Timer and Buzzer Control Register)

Bit 7	Bit 6	Bit 5	Bit 4	Bit 3	Bit 2	Bit 1	Bit 0
WTCS	WTIE	WTIF	WTSSB1	WTSSB0	BUZE	BSSB1	BSSB0

**Bit 7 (WTCS):** Watchdog Timer and Buzzer Clock Source Select Bit

- 0 : Main Clock divided by 256
- 1 : Sub clock

**Bit 6 (WTIE):** Watchdog Timer Enable Bit and Interrupt Mask

- 0 : Disable
- 1 : Enable

**Bit 5 (WTIF):** Watchdog Timer Interrupt Flag

**Bits 4~3 (WTSSB1~ WTSSB0):** Watchdog Timer Interval Select Bits

WTSSB1	WTSSB0	t Timer Interval Select (WTCS=1)
0	0	1.0S
0	1	0.5S
1	0	0.25S
1	1	3.91ms

**Bit 2 (BUZE):** Buzzer Enable and Port 91 as Buzzer Output Pin

- 0 : No action
- 1 : Enable buzzer output

**Bits 1~0 (BSSB1~BSSB0):** Buzzer Output Frequency Select Bits

BSSB1	BSSB0	Buzzer Signal Select (WTCS=1)
0	0	0.5kHz
0	1	1kHz
1	0	2kHz
1	1	4kHz



### 6.2.50 Bank 4 R7 PIOCRR (Port 7 I/O Control Register)

Bit 7	Bit 6	Bit 5	Bit 4	Bit 3	Bit 2	Bit 1	Bit 0
IOC77	IOC76	IOC75	IOC74	IOC73	IOC72	IOC71	IOC70

**Bits 7~0 (IOC77~IOC70):** Port 7 8-Bit I/O Direction Control Registers

0 : Define Port 7 as output port

1 : Define Port 7 as input port

### 6.2.51 Bank 4 R8 PIOCRR (Port 8 I/O Control Register)

Bit 7	Bit 6	Bit 5	Bit 4	Bit 3	Bit 2	Bit 1	Bit 0
IOC87	IOC86	IOC85	IOC84	IOC83	IOC82	IOC81	0

**Bits 7~1 (IOC87~IOC81):** Port 8 7-Bit I/O Direction Control Registers

0 : Define Port 8 as output port

1 : Define Port 8 as input port

**Bit 0:** Reserved

### 6.2.52 Bank 4 R9 PIOCRR (Port 9 I/O Control Register)

Bit 7	Bit 6	Bit 5	Bit 4	Bit 3	Bit 2	Bit 1	Bit 0
IOC97	IOC96	IOC95	IOC94	IOC93	IOC92	IOC91	IOC90

**Bits 7~0 (IOC97~IOC90):** Port 9 8-Bit I/O Direction Control Registers

0 : Define Port 9 as output port

1 : Define Port 9 as input port

### 6.2.53 Bank 4 RA PIOCRR (Port A I/O Control Register)

Bit 7	Bit 6	Bit 5	Bit 4	Bit 3	Bit 2	Bit 1	Bit 0
IOCA7	IOCA6	IOCA5	IOCA4	IOCA3	IOCA2	IOCA1	IOCA0

**Bits 7~0 (IOCA7~IOCA0):** Port A 8-Bit I/O Direction Control Registers

0 : Define Port A as output port

1 : Define Port A as input port



#### 6.2.54 Bank 4 RB PIOC(R)(Port B I/O Control Register)

Bit 7	Bit 6	Bit 5	Bit 4	Bit 3	Bit 2	Bit 1	Bit 0
IOCB7	IOCB6	IOCB5	IOCB4	IOCB3	IOCB2	IOCB1	IOCB0

Bits 7~0 (IOCB7~IOCB0): Port B 8-Bit I/O Direction Control Registers

0 : Define Port B as output port

1 : Define Port B as input port

#### 6.2.55 Bank 4 RC PIOC(R)(Port C I/O Control Register)

Bit 7	Bit 6	Bit 5	Bit 4	Bit 3	Bit 2	Bit 1	Bit 0
1	1	1	1	IOCC3	IOCC2	IOCC1	IOCC0

Bits 7~4: Reserved

Bits 3~0 (IOCC3~IOCC0): Port C 4-Bit I/O Direction Control Registers

0 : Define Port C as output port

1 : Define Port C as input port

#### 6.2.56 Bank 4 RF WKCR (Wake-up Control Register)

Bit 7	Bit 6	Bit 5	Bit 4	Bit 3	Bit 2	Bit 1	Bit 0
INTWK7	INTWK6	INTWK5	INTWK4	INTWK3	INTWK2	INTWK1	INTWK0

Bits 7~0 (INTWK7~INTWK0): External Interrupt 7~0 Wake Up Function Enable Bit

0 : Disable

1 : Enable

#### 6.2.57 Bank 5 R6 UARC2 (UART Control Register 2)

Bit 7	Bit 6	Bit 5	Bit 4	Bit 3	Bit 2	Bit 1	Bit 0
0	0	UARTE	0	UINVEN	0	0	0

Bits 7~6: Reserved

Bit 5 (UARTE): UART Function Enable

0 : UART functions disable. PB4, PB5 as general I/O

1 : UART functions enable. PB4, PB5 as UART Rx, Tx pin

Bit 4: Reserved

Bit 3 (UINVEN): Enable UART TX and Rx Port Inverse Output

0 : Disable Tx and Rx port inverse output

1 : Enable Tx and Rx port inverse output

Bits 2~0: Reserved



### 6.2.58 Bank 5 R7 P7PHCR (Port 7 Pull High Control Register)

Bit 7	Bit 6	Bit 5	Bit 4	Bit 3	Bit 2	Bit 1	Bit 0
PH77	PH76	PH75	PH74	PH73	PH72	PH71	PH70

**Bits 7~0 (PH77~PH70):** Port 7 8-Bit I/O Pull High Control Registers

0 : Pull high disable

1 : Pull high enable

### 6.2.59 Bank 5 R8 P8PHCR (Port 8 Pull High Control Register)

Bit 7	Bit 6	Bit 5	Bit 4	Bit 3	Bit 2	Bit 1	Bit 0
PH87	PH86	PH85	PH84	PH83	PH82	PH81	0

**Bits 7~1 (PH87~PH81):** PORT 8 7-Bit I/O Pull High Control Registers

0 : Pull high disable

1 : Pull high enable

**Bit 0:** Reserved

### 6.2.60 Bank 5 R9 P9PHCR (Port 9 Pull-high Control Register)

Bit 7	Bit 6	Bit 5	Bit 4	Bit 3	Bit 2	Bit 1	Bit 0
PH97	PH96	PH95	PH94	PH93	PH92	PH91	PH90

**Bits 7~0 (PH97~PH90):** Port 9 8-bit I/O Pull-high Control Registers

0 : Pull-high disable

1 : Pull-high enable

### 6.2.61 Bank 5 RA PAPHCR (Port A Pull-high Control Register)

Bit 7	Bit 6	Bit 5	Bit 4	Bit 3	Bit 2	Bit 1	Bit 0
PHA7	PHA6	PHA5	PHA4	PHA3	PHA2	PHA1	PHA0

**Bits 7~0 (PHA7~PHA0):** Port A 8-bit I/O Pull-high Control Registers

0 : Pull-high disable

1 : Pull-high enable



### 6.2.62 Bank 5 RB PBPBHC (Port B Pull-high Control Register)

Bit 7	Bit 6	Bit 5	Bit 4	Bit 3	Bit 2	Bit 1	Bit 0
PHB7	PHB6	PHB5	PHB4	PHB3	PHB2	PHB1	PHB0

Bits 7~0 (PHB7~PHB0): Port B 8-Bit I/O Pull-high Control Registers

0 : Pull-high disable

1 : Pull-high enable

### 6.2.63 Bank 5 RC PCPHCR (Port C Pull High Control Register)

Bit 7	Bit 6	Bit 5	Bit 4	Bit 3	Bit 2	Bit 1	Bit 0
0	0	0	0	PHC3	PHC2	PHC1	PHC0

Bits 7~4: Reserved

Bits 3~0 (PHC3~PHC0): Port C 4-Bit I/O Pull-high Control Registers

0 : Pull high disable

1 : Pull high enable

### 6.2.64 Bank 6 R6 LVRCR (Low Voltage Reset Control Register)

Bit 7	Bit 6	Bit 5	Bit 4	Bit 3	Bit 2	Bit 1	Bit 0
0	0	0	0	0	LVREN	LVRS1	LVRS0

R6 use only ICE510 simulator

Bits 7~3: Reserved

Bit 2 (LVREN): Low Voltage Reset Enable Bit

0 : Disable

1 : Enable

Bits 1~0 (LVRS1~LVRS0): Low Voltage Reset Voltage Select Bits

LVRS1	LVRS0	Reset Voltage
0	0	2.6V
0	1	3.3V
1	0	3.9V

### 6.2.65 Bank 6 R7 PTODCR (Port 7 Open Drain Control Register)

Bit 7	Bit 6	Bit 5	Bit 4	Bit 3	Bit 2	Bit 1	Bit 0
OD77	OD76	OD75	OD74	OD73	OD72	OD71	OD70

Bits 7~0 (OD77~OD70): Port 7 8-Bit I/O Open Drain Control Registers

0 : Open drain disable

1 : Open drain enable



### 6.2.66 Bank 6 R8 P8ODCR (Port 8 Open Drain Control Register)

Bit 7	Bit 6	Bit 5	Bit 4	Bit 3	Bit 2	Bit 1	Bit 0
OD87	OD86	OD85	OD84	OD83	OD82	OD81	0

Bits 7~1 (OD87~OD80): Port 8 7-bit I/O Open Drain Control Registers

0 : Open drain disable

1 : Open drain enable

Bit 0: Reserved

### 6.2.67 Bank 6 R9 P9ODCR (Port 9 Open Drain Control Register)

Bit 7	Bit 6	Bit 5	Bit 4	Bit 3	Bit 2	Bit 1	Bit 0
OD97	OD96	OD95	OD94	OD93	OD92	OD91	OD90

Bits 7~0 (OD97~OD90): Port 9 8-Bit I/O Open Drain Control Registers

0 : Open drain disable

1 : Open drain enable

### 6.2.68 Bank 6 RA PAODCR (Port A Open Drain Control Register)

Bit 7	Bit 6	Bit 5	Bit 4	Bit 3	Bit 2	Bit 1	Bit 0
ODA7	ODA6	ODA5	ODA4	ODA3	ODA2	ODA1	ODA0

Bits 7~0 (ODA7~ODA0): Port A 8-Bit I/O Open Drain Control Registers

0 : Open drain disable

1 : Open drain enable

### 6.2.69 Bank 6 RB PBODCR (Port B Open Drain Control Register)

Bit 7	Bit 6	Bit 5	Bit 4	Bit 3	Bit 2	Bit 1	Bit 0
ODB7	ODB6	ODB5	ODB4	ODB3	ODB2	ODB1	ODB0

Bits 7~0 (ODB7~ODB0): Port B 8-Bit I/O Open Drain Control Registers

0 : Open drain disable

1 : Open drain enable

### 6.2.70 Bank 6 RC (Port C)

Bit 7	Bit 6	Bit 5	Bit 4	Bit 3	Bit 2	Bit 1	Bit 0
1	1	1	1	RC3	RC2	RC1	RC0

Bits 7~4: Reserved

Bits 3~0 (RC3~RC0): Port C 4-Bit I/O Registers

### 6.2.71 R10~R3F (General Purpose Register)

R10~R1F and R20~R3F (Banks 0~7) are general purpose registers.

### 6.3 TCC/WDT Pre-scaler

Registers for the TCC/WDT Circuit

R_BANK	Address	NAME	Bit 7	Bit 6	Bit 5	Bit 4	Bit 3	Bit 2	Bit 1	Bit 0
Bank 0	0X0D	<b>TWTCR</b>	<b>WDTE</b>	<b>WPSR2</b>	<b>WPSR1</b>	<b>WPSR0</b>	<b>TCCS</b>	<b>TPSR2</b>	<b>TPSR1</b>	<b>TPSR0</b>
			R/W	R/W	R/W	R/W	R/W	R/W	R/W	R/W
Bank 0	0x0E	<b>IMR</b>	<b>T1IE</b>	<b>LVDIE</b>	<b>ADIE</b>	<b>SPIIE</b>	<b>URTIE</b>	<b>EXIE9</b>	<b>EXIE8</b>	<b>TCIE</b>
			R/W	R/W	R/W	R/W	R/W	R/W	R/W	R/W
Bank 0	0x0F	<b>ISR</b>	<b>T1IF</b>	<b>LVDIF</b>	<b>ADIF</b>	<b>SPIIF</b>	<b>URTIF</b>	<b>EXIF9</b>	<b>EXIF8</b>	<b>TCIF</b>
			R/W	R/W	R/W	R/W	R/W	R/W	R/W	R/W

There are two 8-bit counters available as prescalers for the TCC and WDT, respectively. The TPSR0~TPSR2 bits of the Bank 0 RD (TWTCR) register are used to determine the ratio of the TCC prescaler. Likewise, the WPSR0~WPSR2 bits of the Bank 0 RD (TWTCR) register are used to determine the WDT prescaler. The prescaler (TPSR0~TPSR2) will be cleared by the instructions each time they are written into TCC. The WDT and prescaler will be cleared by the “WDTC” and “SLEP” instructions. Fig.6-4 depicts the circuit diagram of TCC/WDT.

R1 (TCC) is an 8-bit timer/counter. The TCC clock source can be internal clock main clock or sub clock (32.768kHz). If TCC signal source is from the internal clock, TCC will be incremented by 1 at every instruction cycle (without prescaler). As illustrated in Fig. 6-4. The watchdog timer is a free running on-chip RC oscillator. The WDT will continue running even after the oscillator driver has been turned off (i.e. in sleep mode). During normal operation or sleep mode, a WDT time-out (if enabled) will cause the device to reset. The WDT can be enabled or disabled at any time during the normal mode by software programming. Refer to WDTE bit of Bank 0 RD (TWTCR) register. With no prescaler, the WDT time-out period is approximately 18 ms<sup>1</sup>.

<sup>1</sup> **Note:** VDD=5V, Setup time period = 16.5ms ± 30% VDD=3V, Setup time period = 18ms ± 30%

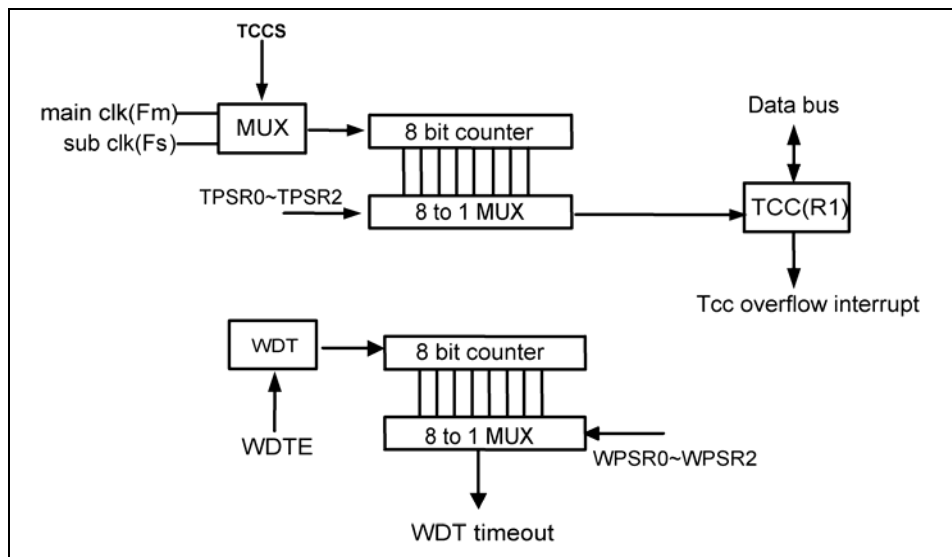

Figure 6-4 TCC/WDT Block Diagram

## 6.4 I/O Port

Registers for I/O Circuit

R_BANK	Address	Name	Bit 7	Bit 6	Bit 5	Bit 4	Bit 3	Bit 2	Bit 1	Bit 0
Bank 4	0X07~0X0C	PIOCR	IOC7	IOC6	IOC5	IOC4	IOC3	IOC2	IOC1	IOC0
			R/W	R/W	R/W	R/W	R/W	R/W	R/W	R/W
Bank 5	0X07~0X0C	PHCR	PH7	PH6	PH5	PH4	PH3	PH2	PH1	PH0
			R/W	R/W	R/W	R/W	R/W	R/W	R/W	R/W
Bank 6	0X07~0X0B	ODCR	OD7	OD6	OD5	OD4	OD3	OD2	OD1	OD0
			R/W	R/W	R/W	R/W	R/W	R/W	R/W	R/W

The I/O registers, (Port 7, Port 8, Port 9, Port A, Port B and Port C), are bidirectional tri-state I/O ports. All pins are pulled-high internally by software. Likewise, Port 7, Port 8, Port 9, Port A, Port B and Port C, can have open-drain output also through software. Port 7 [7:4], Port B [3:0] and Port 8 [3:2] provides an input status changed interrupt (or wake-up) function and is pulled-high by software. Each I/O pin can be defined as "input" or "output" pin by the I/O control register Bank 4 R7 ~ RC. The I/O registers and I/O control registers are both readable and writeable. The I/O interface circuits are shown in Fig. 6-5.

The I/O cannot be set to pull-high and output low at the same time. It can relatively increase the power consumption.

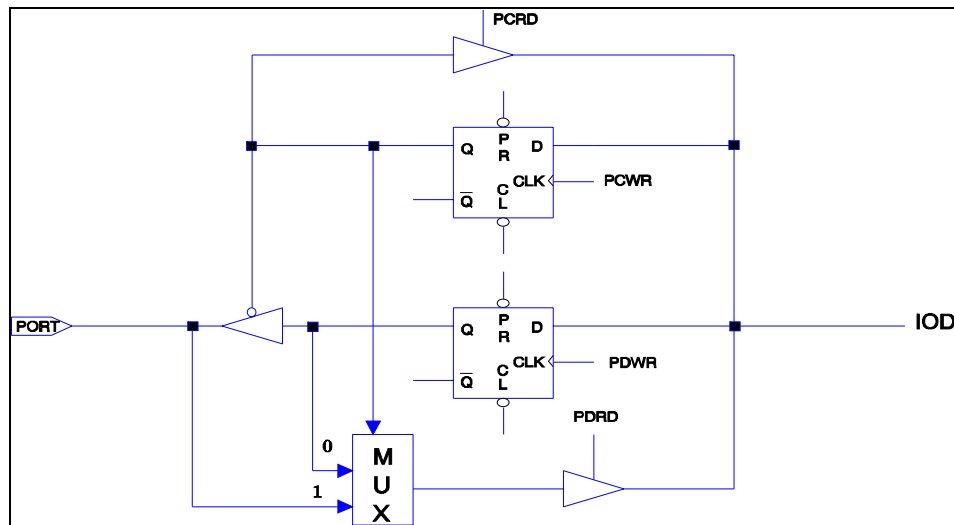

Note: Open-drain is not shown in the figure.

Figure 6-5 Circuits of I/O Port and I/O Control Register for Ports 7~9, and Ports A ~ C

## 6.5 Reset and Wake-up

A Reset can be caused by:

- Power-on reset
- WDT timeout (if enabled)
- LVR Reset (if enabled)
- RESET pin pulls low

### NOTE

*The power-on reset circuit is always enabled, it will reset the CPU at 2.3V and power consumption is 0.5 $\mu$ A.*

Once a Reset occurs, the following functions are performed:

- The oscillator is running, or will be started.
- The Program Counter (R2) is set to all "0".
- All I/O port pins are configured as input mode (high-impedance state).
- The TCC/Watchdog timer and prescaler are cleared.
- When power is on, all bits of R5 and R6 are cleared.
- The other registers are described in Table 2



Table 2 Summary of the Registers Initialized Values

Address	Name	Reset Type	Bit 7	Bit 6	Bit 5	Bit 4	Bit 3	Bit 2	Bit 1	Bit 0
0x00	R0 (IAR)	Bit Name	-	-	-	-	-	-	-	-
		Power-on	U	U	U	U	U	U	U	U
		/RESET and WDT	P	P	P	P	P	P	P	P
		Wake-up from Sleep and Idle mode	P	P	P	P	P	P	P	P
0x01	R1 (TCC)	Bit Name	-	-	-	-	-	-	-	-
		Power-on	0	0	0	0	0	0	0	0
		/RESET and WDT	0	0	0	0	0	0	0	0
		Wake-up from Sleep and Idle mode	P	P	P	P	P	P	P	P
0x02	R2 (PC)	Bit Name	-	-	-	-	-	-	-	-
		Power-on	0	0	0	0	0	0	0	0
		/RESET and WDT	0	0	0	0	0	0	0	0
		Wake-up from Sleep and Idle mode	Continue to execute next instruction							
0x03	R3 (SR)	Bit Name	LV DEN	LV DS1	LV DS0	T	P	Z	DC	C
		Power-on	0	0	0	1	1	U	U	U
		/RESET and WDT	0	0	0	t	t	P	P	P
		Wake-up from Sleep and Idle mode	P	P	P	t	t	P	P	P
0x04	R4 (RSR)	Bit Name	VDB	BNC	X	X	X	X	X	X
		Power-on	1	1	U	U	U	U	U	U
		/RESET and WDT	1	1	P	P	P	P	P	P
		Wake-up from Sleep and Idle mode	P	P	P	P	P	P	P	P
Bank 0 0x05	Bank0 R5 (RBSR)	Bit Name	0	0	0	0	0	BS2	BS1	BS0
		Power-on	0	0	0	0	0	0	0	0
		/RESET and WDT	0	0	0	0	0	0	0	0
		Wake-up from Sleep and Idle mode	P	P	P	P	P	P	P	P
Bank 0 0x06	R6 (RPSR)	Bit Name	0	0	0	0	0	PS2	PS1	PS0
		Power-on	0	0	0	0	0	0	0	0
		/RESET and WDT	0	0	0	0	0	0	0	0
		Wake-up from Sleep and Idle mode	P	P	P	P	P	P	P	P
Bank 0 0x07	R7 (Port 7)	Bit Name	R77	R76	R75	R74	R73	R62	R71	R70
		Power-on	1	1	1	1	1	1	1	1
		/RESET and WDT	1	1	1	1	1	1	1	1
		Wake-up from Sleep and Idle mode	P	P	P	P	P	P	P	P
Bank 0 0x08	R8 (Port 8)	Bit Name	R87	R86	R85	R84	R83	R82	R81	0
		Power-on	1	1	1	1	1	1	1	0
		/RESET and WDT	1	1	1	1	1	1	1	0
		Wake-up from Sleep and Idle mode	P	P	P	P	P	P	P	0



Address	Name	Reset Type	Bit 7	Bit 6	Bit 5	Bit 4	Bit 3	Bit 2	Bit 1	Bit 0
Bank 0 0x09	R9 (Port 9)	Bit Name	R97	R96	R95	R94	R93	R92	R91	R90
		Power-on	1	1	1	1	1	1	1	1
		/RESET and WDT	1	1	1	1	1	1	1	1
		Wake-up from Sleep and Idle mode	P	P	P	P	P	P	P	P
Bank 0 0x0A	RA (Port A)	Bit Name	RA7	RA6	RA5	RA4	RA3	RA2	RA1	RA0
		Power-on	1	1	1	1	1	1	1	1
		/RESET and WDT	1	1	1	1	1	1	1	1
		Wake-up from Sleep and Idle mode	P	P	P	P	P	P	P	P
Bank 0 0x0B	RB (Port B)	Bit Name	RB7	RB6	RB5	RB4	RB3	RB2	RB1	RB0
		Power-on	1	1	1	1	1	1	1	1
		/RESET and WDT	1	1	1	1	1	1	1	1
		Wake-up from Sleep and Idle mode	P	P	P	P	P	P	P	P
Bank 0 0x0C	RC (SCCR)	Bit Name	0	CLK2	CKL1	CLK0	IDLE	0	0	CPUS
		Power-on	0	0	0	0	1	0	0	1
		/RESET and WDT	0	0	0	0	1	0	0	1
		Wake-up from Sleep and Idle mode	P	P	P	P	P	P	P	P
Bank 0 0x0D	RD (TWTCR)	Bit Name	WDTE	WPSR2	WPSR1	WPSR0	TCCS	TPSR2	TPSR1	TPSR0
		Power-on	0	0	0	0	0	0	0	0
		/RESET and WDT	0	0	0	0	0	0	0	0
		Wake-up from Sleep and Idle mode	P	P	P	P	P	P	P	P
Bank 0 0x0E	RE (IMR)	Bit Name	T1IE	LVDIE	ADIE	SPIIE	URTIE	EXIE9	EXIE8	TCIE
		Power-on	0	0	0	0	0	0	0	0
		/RESET and WDT	0	0	0	0	0	0	0	0
		Wake-up from Sleep and Idle mode	P	P	P	P	P	P	P	P
Bank 0 0x0F	RF (ISR)	Bit Name	T1IF	LVDIF	ADIF	SPIIF	URTIF	EXIF9	EXIF8	TCIF
		Power-on	0	0	0	0	0	0	0	0
		/RESET and WDT	0	0	0	0	0	0	0	0
		Wake-up from Sleep and Idle mode	P	P	P	P	P	P	P	P
Bank 1 0x05	Bank1 R5 (LCDCR)	Bit Name	LCDEN	LCDPYTE	BS1	BS0	DS1	DS0	LCDF1	LCDF0
		Power-on	0	0	0	0	0	0	0	0
		/RESET and WDT	0	0	0	0	0	0	0	0
		Wake-up from Sleep and Idle mode	P	P	P	P	P	P	P	P
Bank 1 0x06	R6 (LCDAR)	Bit Name	0	0	0	LCD_A4	LCD_A3	LCD_A2	LCD_A1	LCD_A0
		Power-on	0	0	0	0	0	0	0	0
		/RESET and WDT	0	0	0	0	0	0	0	0
		Wake-up from Sleep and Idle mode	P	P	P	P	P	P	P	P



Address	Name	Reset Type	Bit 7	Bit 6	Bit 5	Bit 4	Bit 3	Bit 2	Bit 1	Bit 0
Bank 1 0X07	R7 (LCDBR)	Bit Name	LCD_D7	LCD_D6	LCD_D5	LCD_D4	LCD_D3	LCD_D2	LCD_D1	LCD_D0
		Power-on	0	0	0	0	0	0	0	0
		/RESET and WDT	0	0	0	0	0	0	0	0
		Wake-up from Sleep and Idle mode	P	P	P	P	P	P	P	P
Bank 1 0X08	R8 (LCDVCR)	Bit Name	0	0	0	LCDC1	LCDC0	LCDVC2	LCDVC1	LCDVC0
		Power-on	0	0	0	1	1	1	1	1
		/RESET and WDT	0	0	0	1	1	1	1	1
		Wake-up from Sleep and Idle mode	P	P	P	P	P	P	P	P
Bank 1 0X09	R9 (LCDCCR)	Bit Name	COM7	COM6	COM5	COM4	COM3	COM2	COM1	COM0
		Power-on	0	0	0	0	0	0	0	0
		/RESET and WDT	0	0	0	0	0	0	0	0
		Wake-up from Sleep and Idle mode	P	P	P	P	P	P	P	P
Bank 1 0X0A	RA (LCDSCR0)	Bit Name	SEG7	SEG6	SEG5	SEG4	SEG3	SEG2	SEG1	SEG0
		Power-on	0	0	0	0	0	0	0	0
		/RESET and WDT	0	0	0	0	0	0	0	0
		Wake-up from Sleep and Idle mode	P	P	P	P	P	P	P	P
Bank 1 0X0B	RB (LCDSCR1)	Bit Name	SEG15	SEG14	SEG13	SEG12	SEG11	SEG10	SEG9	SEG8
		Power-on	0	0	0	0	0	0	0	0
		/RESET and WDT	0	0	0	0	0	0	0	0
		Wake-up from Sleep and Idle mode	P	P	P	P	P	P	P	P
Bank 1 0X0C	RC (LCDSCR2)	Bit Name	0	SEG22	SEG21	SEG20	SEG19	SEG18	SEG17	SEG16
		Power-on	0	0	0	0	0	0	0	0
		/RESET and WDT	0	0	0	0	0	0	0	0
		Wake-up from Sleep and Idle mode	P	P	P	P	P	P	P	P
Bank 1 0X0E	RE (EIMR)	Bit Name	EXIE7	EXIE6	EXIE5	EXIE4	EXIE3	EXIE2	EXIE1	EXIE0
		Power-on	0	0	0	0	0	0	0	0
		/RESET and WDT	0	0	0	0	0	0	0	0
		Wake-up from Sleep and Idle mode	P	P	P	P	P	P	P	P
Bank 1 0X0F	RF (EISR)	Bit Name	EXIF7	EXIF6	EXIF5	EXIF4	EXIF3	EXIF2	EXIF1	EXIF0
		Power-on	0	0	0	0	0	0	0	0
		/RESET and WDT	0	0	0	0	0	0	0	0
		Wake-up from Sleep and Idle mode	P	P	P	P	P	P	P	P
Bank 2 0X05	Bank2 R5 (T1CR)	Bit Name	TIS1	TIS0	T1MS2	T1MS1	TIMS0	T1P2	T1P1	T1P0
		Power-on	0	0	0	0	0	0	0	0
		/RESET and WDT	0	0	0	0	0	0	0	0
		Wake-up from Sleep and Idle mode	P	P	P	P	P	P	P	P



Address	Name	Reset Type	Bit 7	Bit 6	Bit 5	Bit 4	Bit 3	Bit 2	Bit 1	Bit 0
Bank 2 0X06	R6 (TSR)	Bit Name	T1MOD	TCRB	T1CSS1	T1CSS0	T2CSS	T1S	T1OMS	T1OC
		Power-on	0	0	0	0	0	0	0	0
		/RESET and WDT	0	0	0	0	0	0	0	0
		Wake-up from Sleep and Idle mode	P	P	P	P	P	P	P	P
Bank 2 0X07	R7 (T1PD)	Bit Name	PRD1[7]	PRD1[6]	PRD1[5]	PRD1[4]	PRD1[3]	PRD1[2]	PRD1[1]	PRD1[0]
		Power-on	0	0	0	0	0	0	0	0
		/RESET and WDT	0	0	0	0	0	0	0	0
		Wake-up from Sleep and Idle mode	P	P	P	P	P	P	P	P
Bank 2 0x08	R8 (T1TD)	Bit Name	TD1[7]	TD1[6]	TD1[5]	TD1[4]	TD1[3]	TD1[2]	TD1[1]	TD1[0]
		Power-on	0	0	0	0	0	0	0	0
		/RESET and WDT	0	0	0	0	0	0	0	0
		Wake-up from Sleep and Idle mode	P	P	P	P	P	P	P	P
Bank 2 0X09	R9 (T2CR)	Bit Name	T2IF	T2IE	T2S	T2MS1	T2MS0	T2P2	T2P1	T2P0
		Power-on	0	0	0	0	0	0	0	0
		/RESET and WDT	0	0	0	0	0	0	0	0
		Wake-up from Sleep and Idle mode	P	P	P	P	P	P	P	P
Bank 2 0X0A	RA (T2PD)	Bit Name	PRD2[7]	PRD2[6]	PRD2[5]	PRD2[4]	PRD2[3]	PRD2[2]	PRD2[1]	PRD2[0]
		Power-on	0	0	0	0	0	0	0	0
		/RESET and WDT	0	0	0	0	0	0	0	0
		Wake-up from Sleep and Idle mode	P	P	P	P	P	P	P	P
Bank 2 0X0B	RB (T2TD)	Bit Name	TD2[7]	TD2[6]	TD2[5]	TD2[4]	TD2[3]	TD2[2]	TD2[1]	TD2[0]
		Power-on	0	0	0	0	0	0	0	0
		/RESET and WDT	0	0	0	0	0	0	0	0
		Wake-up from Sleep and Idle mode	P	P	P	P	P	P	P	P
Bank 2 0X0C	RC (SPIS)	Bit Name	DORD	TD1	TD0	0	OD3	OD4	0	RBF
		Power-on	0	0	0	0	0	0	0	0
		/RESET and WDT	0	0	0	0	0	0	0	0
		Wake-up from Sleep and Idle mode	P	P	P	P	P	P	P	P
Bank 2 0X0D	RD (SPIC)	Bit Name	CES	SPIE	SRO	SSE	SDOC	SBRS2	SBRS1	SBRS0
		Power-on	0	0	0	0	0	0	0	0
		/RESET and WDT	0	0	0	0	0	0	0	0
		Wake-up from Sleep and Idle mode	P	P	P	P	P	P	P	P
Bank 2 0X0E	RE (SPIR)	Bit Name	SRB7	SRB6	SRB5	SRB4	SRB3	SRB2	SRB1	SRB0
		Power-on	U	U	U	U	U	U	U	U
		/RESET and WDT	U	U	U	U	U	U	U	U
		Wake-up from Sleep and Idle mode	P	P	P	P	P	P	P	P



Address	Name	Reset Type	Bit 7	Bit 6	Bit 5	Bit 4	Bit 3	Bit 2	Bit 1	Bit 0
Bank 2 0X0F	RF (SPIW)	Bit Name	SWB7	SWB6	SWB5	SWB4	SWB3	SWB2	SWB1	SWB0
		Power-on	U	U	U	U	U	U	U	U
		/RESET and WDT	U	U	U	U	U	U	U	U
		Wake-up from Sleep and Idle mode	P	P	P	P	P	P	P	P
Bank 3 0x05	Bank3 R5 (URC)	Bit Name	URTD8	UMODE1	UMODE0	BRATE2	BRATE1	BRATE0	UTBE	TXE
		Power-on	U	0	0	0	0	0	0	0
		/RESET and WDT	P	0	0	0	0	0	0	0
		Wake-up from Sleep and Idle mode	P	P	P	P	P	P	P	P
Bank 3 0x06	R6 (URS)	Bit Name	URRD8	EVEN	PRE	PRERR	OVERR	FMERR	URBF	RXE
		Power-on	U	0	0	0	0	0	0	0
		/RESET and WDT	P	0	0	0	0	0	0	0
		Wake-up from Sleep and Idle mode	P	P	P	P	P	P	P	P
Bank 3 0x07	R7 (URRD)	Bit Name	URRD7	URRD6	URRD5	URRD4	URRD3	URRD2	URRD1	URRD0
		Power-on	0	0	0	0	0	0	0	0
		/RESET and WDT	P	P	P	P	P	P	P	P
		Wake-up from Sleep and Idle mode	P	P	P	P	P	P	P	P
Bank 3 0x08	R8 (URTD)	Bit Name	URTD7	URTD6	URTD5	URTD4	URTD3	URTD2	URTD1	URTD0
		Power-on	0	0	0	0	0	0	0	0
		/RESET and WDT	P	P	P	P	P	P	P	P
		Wake-up from Sleep and Idle mode	P	P	P	P	P	P	P	P
Bank 3 0x09	R9 (ADCR)	Bit Name	ADRUN	ADP	ADCK1	ADCK0	ADIS3	ADIS2	ADIS1	ADIS0
		Power-on	0	0	0	0	0	0	0	0
		/RESET and WDT	0	0	0	0	0	0	0	0
		Wake-up from Sleep and Idle mode	P	P	P	P	P	P	P	P
Bank 3 0x0A	RA (ADICH)	Bit Name	CALI	ADREF	0	0	ADE11	ADE10	ADE9	ADE8
		Power-on	0	0	0	0	0	0	0	0
		/RESET and WDT	0	0	0	0	0	0	0	0
		Wake-up from Sleep and Idle mode	P	P	P	P	P	P	P	P
Bank 3 0x0B	RB (ADICL)	Bit Name	ADE7	ADE6	ADE5	ADE4	ADE3	ADE2	ADE1	ADE0
		Power-on	0	0	0	0	0	0	0	0
		/RESET and WDT	0	0	0	0	0	0	0	0
		Wake-up from Sleep and Idle mode	P	P	P	P	P	P	P	P
Bank 3 0x0C	RC (ADDH)	Bit Name	ADD11	ADD10	ADD9	ADD8	ADD7	ADD6	ADD5	ADD4
		Power-on	0	0	0	0	0	0	0	0
		/RESET and WDT	0	0	0	0	0	0	0	0
		Wake-up from Sleep and Idle mode	P	P	P	P	P	P	P	P



Address	Name	Reset Type	Bit 7	Bit 6	Bit 5	Bit 4	Bit 3	Bit 2	Bit 1	Bit 0
Bank 3 0x0D	RD (ADDL)	Bit Name	SIGN	VOF[2]	VOF[1]	VOF[0]	ADD3	ADD2	ADD1	ADD0
		Power-on	0	0	0	0	0	0	0	0
		/RESET and WDT	0	0	0	0	0	0	0	0
		Wake-up from Sleep and Idle mode	P	P	P	P	P	P	P	P
Bank 3 0x0E	RE (EIESH)	Bit Name	EIES7	EIES6	EIES5	EIES4	EIES3	EIES2	EIES1	EIES0
		Power-on	0	0	0	0	0	0	0	0
		/RESET and WDT	0	0	0	0	0	0	0	0
		Wake-up from Sleep and Idle mode	P	P	P	P	P	P	P	P
Bank 3 0x0F	RF (EIESL)	Bit Name	0	0	0	ADWK	INTWK9	INTWK8	EIES9	EIES8
		Power-on	0	0	0	0	0	0	0	0
		/RESET and WDT	0	0	0	0	0	0	0	0
		Wake-up from Sleep and Idle mode	P	P	P	P	P	P	P	P
Bank 4 0x05	Bank4 R5 (LEDDCR)	Bit Name	LEDD7	LEDD6	LEDD5	LEDD4	LEDD3	LEDD2	LEDD1	LEDD0
		Power-on	0	0	0	0	0	0	0	0
		/RESET and WDT	0	0	0	0	0	0	0	0
		Wake-up from Sleep and Idle mode	P	P	P	P	P	P	P	P
Bank 4 0x06	R6 (WBCR)	Bit Name	WTCS	WTIE	WTIF	WTSSB1	WTSSB0	BUZE	BSSB1	BSSB0
		Power-on	0	0	0	0	0	0	0	0
		/RESET and WDT	0	0	0	0	0	0	0	0
		Wake-up from Sleep and Idle mode	P	P	P	P	P	P	P	P
Bank 4 0x07	R7 (IOC7)	Bit Name	IOC77	IOC76	IOC75	IOC74	IOC73	IOC72	IOC71	IOC70
		Power-on	1	1	1	1	1	1	1	1
		/RESET and WDT	1	1	1	1	1	1	1	1
		Wake-up from Sleep and Idle mode	P	P	P	P	P	P	P	P
Bank 4 0x08	R8 (IOC8)	Bit Name	IOC87	IOC86	IOC85	IOC84	IOC83	IOC82	IOC81	0
		Power-on	1	1	1	1	1	1	1	0
		/RESET and WDT	1	1	1	1	1	1	1	0
		Wake-up from Sleep and Idle mode	P	P	P	P	P	P	P	P
Bank 4 0x09	R9 (IOC9)	Bit Name	IOC97	IOC96	IOC95	IOC94	IOC93	IOC92	IOC91	IOC90
		Power-on	1	1	1	1	1	1	1	1
		/RESET and WDT	1	1	1	1	1	1	1	1
		Wake-up from Sleep and Idle mode	P	P	P	P	P	P	P	P
Bank 4 0x0A	RA (IOCA)	Bit Name	IOCA7	IOCA6	IOCA5	IOCA4	IOCA3	IOCA2	IOCA1	IOCA0
		Power-on	1	1	1	1	1	1	1	1
		/RESET and WDT	1	1	1	1	1	1	1	1
		Wake-up from Sleep and Idle mode	P	P	P	P	P	P	P	P



Address	Name	Reset Type	Bit 7	Bit 6	Bit 5	Bit 4	Bit 3	Bit 2	Bit 1	Bit 0
Bank 4 0x0B	RB (IOCB)	Bit Name	IOCB7	IOCB6	IOCB5	IOCB4	IOCB3	IOCB2	IOCB1	IOCB0
		Power-on	1	1	1	1	1	1	1	1
		/RESET and WDT	1	1	1	1	1	1	1	1
		Wake-up from Sleep and Idle mode	P	P	P	P	P	P	P	P
Bank 4 0x0C	RC (IOCC)	Bit Name	1	1	1	1	IOCC3	IOCC2	IOCC1	IOCC0
		Power-on	1	1	1	1	1	1	1	1
		/RESET and WDT	1	1	1	1	1	1	1	1
		Wake-up from Sleep and Idle mode	P	P	P	P	P	P	P	P
Bank 4 0x0F	RF (WKCR)	Bit Name	NTWK7	INTWK6	INTWK5	INTWK4	INTWK3	INTWK2	INTWK1	INTWK0
		Power-on	0	0	0	0	0	0	0	0
		/RESET and WDT	0	0	0	0	0	0	0	0
		Wake-up from Sleep and Idle mode	P	P	P	P	P	P	P	P
Bank 5 0x06	Bank5 R6 (UARC2)	Bit Name	0	0	UARTE	0	UINVEN	0	0	0
		Power-on	0	0	0	0	0	0	0	0
		/RESET and WDT	0	0	0	0	0	0	0	0
		Wake-up from Sleep and Idle mode	P	P	P	P	P	P	P	P
Bank 5 0x07	R7 (P7PHCR)	Bit Name	PH77	PH76	PH75	PH74	PH73	PH72	PH71	PH70
		Power-on	0	0	0	0	0	0	0	0
		/RESET and WDT	0	0	0	0	0	0	0	0
		Wake-up from Sleep and Idle mode	P	P	P	P	P	P	P	P
Bank 5 0x08	R8 (P8PHCR)	Bit Name	PH87	PH86	PH85	PH84	PH83	PH82	PH81	0
		Power-on	0	0	0	0	0	0	0	0
		/RESET and WDT	0	0	0	0	0	0	0	0
		Wake-up from Sleep and Idle mode	P	P	P	P	P	P	P	P
Bank 5 0x09	R9 (P9PHCR)	Bit Name	PH97	PH96	PH95	PH94	PH93	PH92	PH91	PH90
		Power-on	0	0	0	0	0	0	0	0
		/RESET and WDT	0	0	0	0	0	0	0	0
		Wake-up from Sleep and Idle mode	P	P	P	P	P	P	P	P
Bank 5 0x0A	RA (PAPHCR)	Bit Name	PHA7	PHA6	PHA5	PHA4	PHA3	PHA2	PHA1	PHA0
		Power-on	0	0	0	0	0	0	0	0
		/RESET and WDT	0	0	0	0	0	0	0	0
		Wake-up from Sleep and Idle mode	P	P	P	P	P	P	P	P
Bank 5 0x0B	RB (PBPHCR)	Bit Name	PHB7	PHB6	PHB5	PHB4	PHB3	PHB2	PHB1	PHB0
		Power-on	0	0	0	0	0	0	0	0
		/RESET and WDT	0	0	0	0	0	0	0	0
		Wake-up from Sleep and Idle mode	P	P	P	P	P	P	P	P



Address	Name	Reset Type	Bit 7	Bit 6	Bit 5	Bit 4	Bit 3	Bit 2	Bit 1	Bit 0
Bank 5 0x0C	RC (PCPHCR)	Bit Name	0	0	0	0	PHC3	PHC2	PHC1	PHC0
		Power-on	0	0	0	0	0	0	0	0
		/RESET and WDT	0	0	0	0	0	0	0	0
		Wake-up from Sleep and Idle mode	P	P	P	P	P	P	P	P
Bank 6 0x07	Bank6 R7 (P7ODCR)	Bit Name	OD77	OD76	OD75	OD74	OD73	OD72	OD71	OD70
		Power-on	0	0	0	0	0	0	0	0
		/RESET and WDT	0	0	0	0	0	0	0	0
		Wake-up from Sleep and Idle mode	P	P	P	P	P	P	P	P
Bank 6 0x08	R8 (P8ODCR)	Bit Name	OD87	OD86	OD85	OD84	OD83	OD82	OD81	0
		Power-on	0	0	0	0	0	0	0	0
		/RESET and WDT	0	0	0	0	0	0	0	0
		Wake-up from Sleep and Idle mode	P	P	P	P	P	P	P	P
Bank 6 0x09	R9 (P9ODCR)	Bit Name	OD97	OD96	OD95	OD94	OD93	OD92	OD91	OD90
		Power-on	0	0	0	0	0	0	0	0
		/RESET and WDT	0	0	0	0	0	0	0	0
		Wake-up from Sleep and Idle mode	P	P	P	P	P	P	P	P
Bank 6 0x0A	RA (PAODCR)	Bit Name	ODA7	ODA6	ODA5	ODA4	ODA3	ODA2	ODA1	ODA0
		Power-on	0	0	0	0	0	0	0	0
		/RESET and WDT	0	0	0	0	0	0	0	0
		Wake-up from Sleep and Idle mode	P	P	P	P	P	P	P	P
Bank 6 0x0B	RB (PBODCR)	Bit Name	ODB7	ODB6	ODB5	ODB4	ODB3	ODB2	ODB1	ODB0
		Power-on	0	0	0	0	0	0	0	0
		/RESET and WDT	0	0	0	0	0	0	0	0
		Wake-up from Sleep and Idle mode	P	P	P	P	P	P	P	P
Bank 6 0x0C	RC (Port C)	Bit Name	1	1	1	1	RC3	RC2	RC1	RC0
		Power-on	1	1	1	1	1	1	1	1
		/RESET and WDT	1	1	1	1	1	1	1	1
		Wake-up from Sleep and Idle mode	P	P	P	P	P	P	P	P
Bank 0~ Bank 7 0x10~ 0x3F	R10~R3F	Bit Name	-	-	-	-	-	-	-	-
		Power-on	U	U	U	U	U	U	U	U
		/RESET and WDT	U	U	U	U	U	U	U	U
		Wake-up from Sleep and Idle mode	P	P	P	P	P	P	P	P

**Legend:** "x" = not used "P" = previous value before Wake-up or reset  
"u" = unknown or don't care



The controller can be awakened from sleep mode and idle mode. The wake-up signals list as following.

Wake-up Signal	Sleep Mode	Idle Mode	Green Mode	Normal Mode
TCC time out	×	Wake-up + interrupt + next instruction	Interrupt	Interrupt
INT pin	Wake-up + interrupt (if enabled) + next instruction	Wake-up + interrupt(if enabled) + next instruction	Interrupt	Interrupt
Timer 1	×	Wake-up + interrupt + next instruction	Interrupt	Interrupt
Timer 2	×	Wake-up + interrupt + next instruction	Interrupt	Interrupt
UART	×	Wake-up + interrupt + next instruction	Interrupt	Interrupt
SPI	×	×	Interrupt	Interrupt
LVD	×	Wake-up + interrupt + next instruction	Interrupt	Interrupt
A/D	Wake-up + interrupt(if enabled) + next instruction	Wake-up + interrupt(if interrupt enable) + next instruction	Interrupt	Interrupt
Watchdog Timer	×	Wake-up + interrupt + next instruction	Interrupt	Interrupt
WDT time out	RESET	RESET	RESET	RESET

**Note:** User must set the wake-up register (Bank 3 RF(EIESL) Bits 2~4 and Bank 4 RF(WKCR) Bits 0~7).  
 Wake up from INT pin or A/D in sleep and idle mode

After wake up:

1. If interrupt is enabled → interrupt+ next instruction
2. If interrupt is disabled → next instruction

## 6.6 Oscillator

### 6.6.1 Oscillator Modes

The EM78P510N can be operated in the three different oscillator modes for the main oscillator (R-OSCI, OSCO), namely, RC oscillator with external resistor and Internal capacitor mode (IC), crystal oscillator mode, and PLL operation mode. User can select one of those three modes by programming FMMD1 and FMMD0 in the Code Option register, the sub-oscillator can be operated in crystal mode and ERIC mode. Table 3 shows these three modes are defined.

Table 3 Oscillator Modes Defined by FSMD, FMMD1, FMMD0.

FSMD	FMMD1	FMMD0	Main Clock	Sub-clock
0	0	0	RC type (ERIC)	RC type (ERIC)
0	0	1	Crystal type	RC type (ERIC)
0	1	0	PLL type	RC type (ERIC)
0	1	1	PLL type	RC type (ERIC)
1	0	0	RC type (ERIC)	Crystal type
1	0	1	Crystal type	Crystal type
1	1	0	PLL type	Crystal type
1	1	1	Crystal	None

Table 4 Summary of Maximum Operating Speeds

Conditions	VDD	Fxt max.(MHz)
Two clocks	2.0	4
	3.0	8
	5.0	16

### 6.6.2 Crystal Oscillator/Ceramic Resonators (Crystal)

EM78P510N can be driven by an external clock signal through the OSCO pin as shown in Fig.6-6 below.

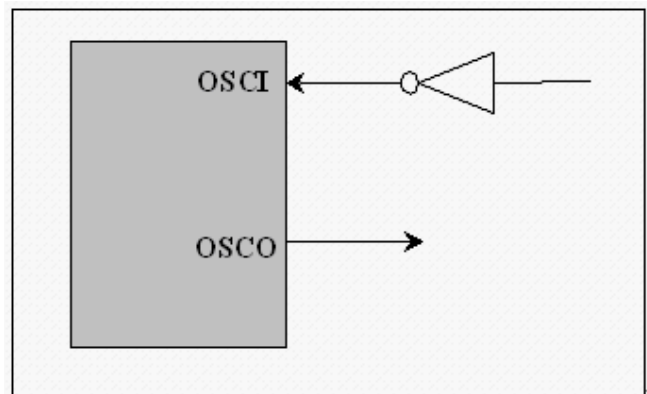

Figure 6-6 External Clock Input Circuit

In most applications, pin R-OSCI and pin OSCO can be connected with a crystal or ceramic resonator to generate oscillation. Fig. 6-7 depicts such circuitry. Table 5 provides the recommended values of C1 and C2. Since each resonator has its own attribute, user should refer to its specification for appropriate values of C1 and C2. RS, a serial resistor, may be necessary for AT strip cut crystal or low frequency mode.

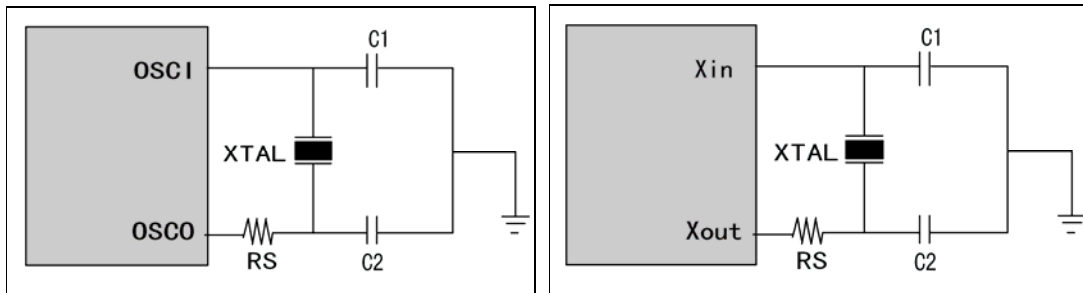

Fig. 6-7 Circuit for Crystal/Resonator

Table 5 Capacitor Selection Guide for Crystal Oscillator or Ceramic Resonators

Oscillator Source	Oscillator Type	Frequency	C1 (pF)	C2 (pF)	
Main Oscillator	Ceramic Resonators	455kHz	30	30	
		2.0 MHz	30	30	
		4.0 MHz	30	30	
	Crystal Oscillator	100K~1MHz	100kHz	68	68
			200kHz	30	30
			455kHz	30	30
		1M~6MHz	1.0MHz	30	30
			2.0MHz	30	30
			4.0MHz	30	30
		6M~12MHz	6.0MHz	30	30
			8.0MHz	30	30
			10.0MHz	30	30
		12M~20MHz	12.0MHz	30	30
			16.0MHz	20	20
			20.0MHz	15	15
Sub-oscillator	Crystal Oscillator	32.768kHz	40	40	

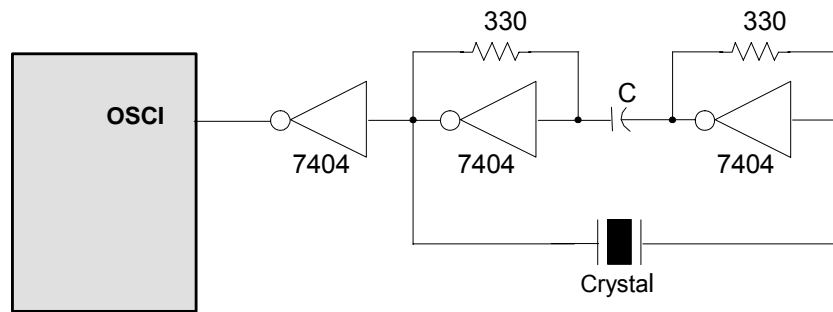

Fig. 6-8 Circuit for Crystal/Resonator-Series Mode

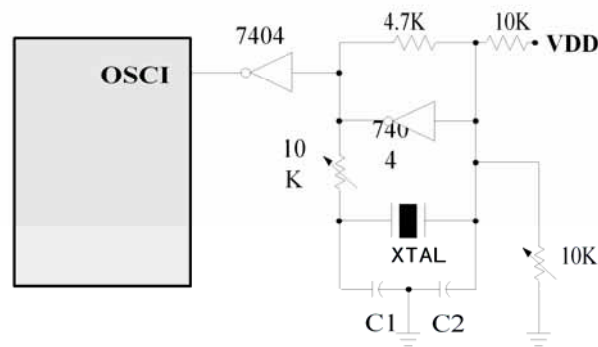

Fig. 6-9 Circuit for Crystal/Resonator-Parallel Mode

### 6.6.3 RC Oscillator Mode with Internal Capacitor

If both precision and cost are taken into consideration, the EM78P510N also offers a special oscillation mode, which has a built-in internal capacitor and an external resistor connected to Vcc. The internal capacitor functions as temperature compensator. In order to obtain more accurate frequency, a precise resistor is recommended.

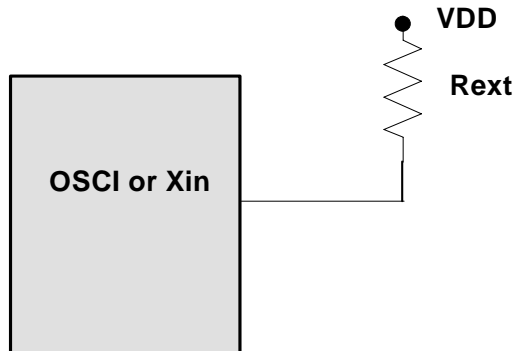

Fig. 6-10 Circuit for Internal C Oscillator Mode

Table 6 R Oscillator Frequencies

Pin	Rext	Average Fosc 5V, 25°C	Average Fosc 3V, 25°C
R-OSCI	51k	2.2221 MHz	2.1972 MHz
	100k	1.1345 MHz	1.1203 MHz
	300k	381.36kHz	374.77kHz
Xin	2.2M	32.768kHz	32.768kHz

Note: <sup>1</sup>: Measured based on DIP packages.

<sup>2</sup>: The values are for design reference only.

### 6.6.4 Phase Lock Loop (PLL Mode)

When operating in PLL mode, the High frequency is determined by the sub-oscillator. RC (Bank 0) register can be chosen to change to high oscillator frequency. The relation between high frequency (Fm) and sub-oscillator is shown on the table below:

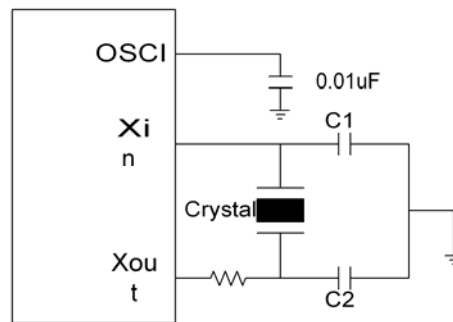

Fig. 6-11 Circuit for PLL mode

**Bits 4~6 (CLK0~CLK2) of RC (Bank 0): Main Clock Selection Bits for PLL Mode**  
(Code Option Select)

CLK2	CLK1	CLK0	Main Clock	Example Fs = 32.768K
0	0	0	Fs × 122	3.997 MHz
0	0	1	Fs × 61	1.998 MHz
0	1	0	Fs × 61/2	0.999 MHz (default)
0	1	1	Fs × 61/4	499.7 kHz
1	0	0	Fs × 244	7.995 MHz
1	0	1	Fs × 366	11.99 MHz
1	1	X	Fs × 488	15.99 MHz

## 6.7 Power-on Considerations

Any microcontroller is not warranted to start operating properly before the power supply stabilizes in steady state. The EM78P510N has a built-in Power-on Reset (POR) with detection level range of 1.9V to 2.1V. The circuitry eliminates the extra external reset circuit. It will work well if VDD rises quickly enough (50 ms or less). However, under critical applications, extra devices are still required to assist in solving power-on problems.

### 6.7.1 External Power-on Reset Circuit

The circuit shown in Fig.6-12 implements an external RC to produce a reset pulse. The pulse width (time constant) should be kept long enough to allow VDD to reach minimum operation voltage. This circuit is used when the power supply has a slow rise time. Because the current leakage from the /RESET pin is about  $\pm 5\mu\text{A}$ , it is recommended that R should not be greater than 40K. In this way, the voltage at Pin /RESET is held below 0.2V. The diode (D) acts as a short circuit at power-down. The capacitor, C, is discharged rapidly and fully. Rin, the current-limited resistor, prevents high current discharge or ESD (electrostatic discharge) from flowing into Pin /RESET.

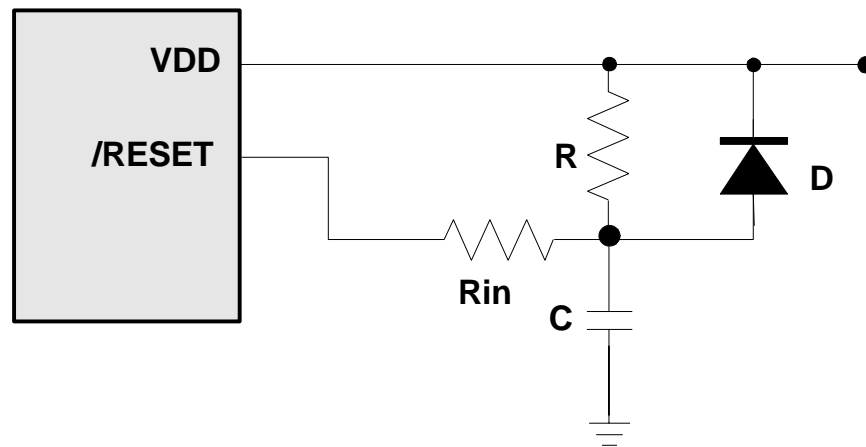

Fig. 6-12 External Power-on Reset Circuit

### 6.7.2 Residue-Voltage Protection

When battery is replaced, device power (VDD) is taken off but residue-voltage remains. The residue-voltage may trips below Vdd minimum, but not to zero. This condition may cause a poor power-on reset. Fig.6-13 and Fig.6-14 show how to build a residue-voltage protection circuit.

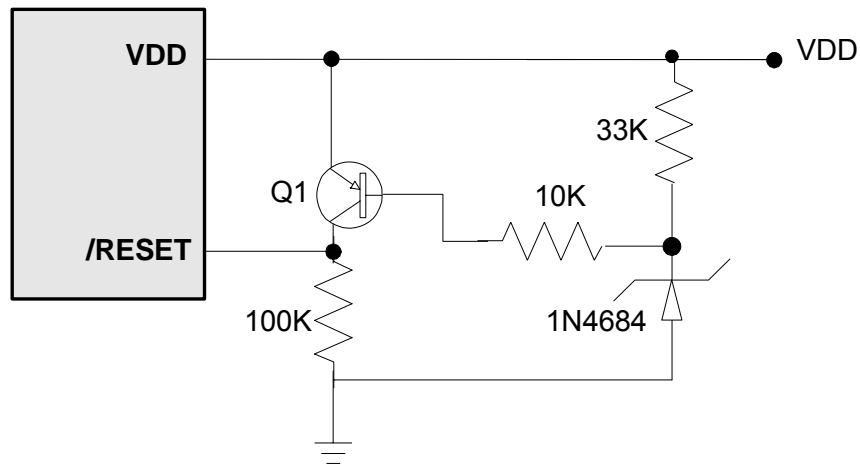

Fig. 6-13 Residue Voltage Protection Circuit 1

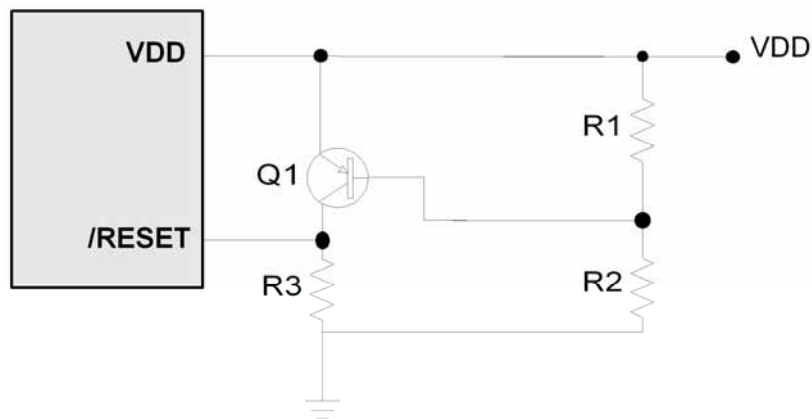

Fig. 6-14 Residue Voltage Protection Circuit 2



## 6.8 Interrupt

Registers for Interrupt

R_BANK	Address	Name	Bit 7	Bit 6	Bit 5	Bit 4	Bit 3	Bit 2	Bit 1	Bit 0
Bank 0	0x0E	IMR	T1IE	LVDIE	ADIE	SPIIE	URTIE	EXIE9	EXIE8	TCIE
			R/W	R/W	R/W	R/W	R/W	R/W	R/W	R/W
Bank 0	0x0F	ISR	T1IF	LVDIF	ADIF	SPIIF	URTIF	EXIF9	EXIF8	TCIF
			R/W	R/W	R/W	R/W	R/W	R/W	R/W	R/W
Bank 1	0X0E	EIMR	EXIE7	EXIE6	EXIE5	EXIE4	EXIE3	EXIE2	EXIE1	EXIE0
			R/W	R/W	R/W	R/W	R/W	R/W	R/W	R/W
Bank 1	0X0F	EISR	EXIF7	EXIF6	EXIF5	EXIF4	EXIF3	EXIF2	EXIF1	EXIF0
			R/W	R/W	R/W	R/W	R/W	R/W	R/W	R/W
Bank 2	0X09	T2CR	T2IF	T2IE	T2S	T2MS1	T2MS0	T2P2	T2P1	T2P0
			R/W	R/W	R/W	R/W	R/W	R/W	R/W	R/W

The EM78P510N has ten interrupt sources as listed below:

- TCC overflow interrupt
- External interrupt pin
- Watchdog timer interrupt
- Timer 1 overflow interrupt
- Timer 2 overflow interrupt
- A/D conversion complete interrupt
- UART transmit interrupt
- SPI transmit/receive interrupt
- Low voltage detector

This IC has internal interrupts which are falling edge triggered, as follows: TCC timer overflow interrupt, and two 8-bit upper counter/timer overflow interrupt. If these interrupt sources change signal from high to low, the RF register will generate a “1” flag to the corresponding register if RE register is enabled.

RF is the interrupt status register which records the interrupt request in flag bit. RE is the interrupt mask register. Global interrupt is enabled by ENI instruction and is disabled by DISI instruction. When one of the interrupts (when enabled) is generated, it will cause the next instruction to be fetched from address 0003H~001BH according to the interrupt source.

For EM78P510N, each individual interrupt source has its own interrupt vector as depicted in Table 7.

Before the interrupt subroutine is executed, the contents of ACC, R3[4:0] and the R5 register will be saved by hardware. After the interrupt service routine is finished, ACC, R3[4:0] and R5 will be pushed back. While in interrupt service routine, other interrupt service routine should not be allowed to be executed, so if other interrupts occur in an interrupt service routine, the hardware will save this interrupt, after which when interrupt service routine is completed, the next interrupt service routine will be executed.

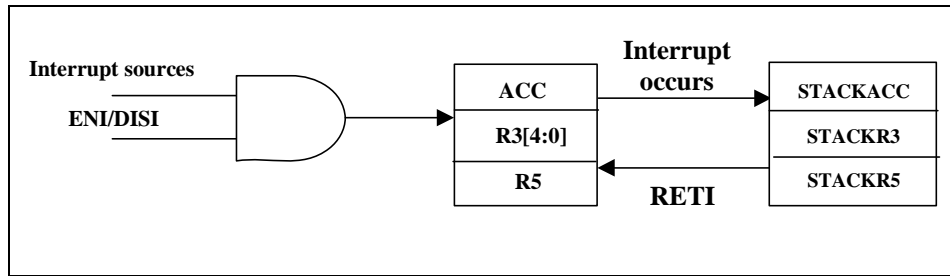

Fig. 6-15 Interrupt Backup Diagram

Table 7 Interrupt Vector

Interrupt Vector	Interrupt Status
0003H	TCC overflow interrupt
0006H	External interrupt
0009H	Watchdogdog timer interrupt
000CH	Timer 1 overflow interrupt
000FH	Timer 2 overflow interrupt
0012H	A/D conversion complete interrupt
0015H	UART transmit complete interrupt
0018H	SPI transmit/receive complete interrupt
001BH	Low voltage detector interrupt

## 6.9 LCD Driver

Registers for LCD Driver Circuit

R_BANK	Address	Name	Bit 7	Bit 6	Bit 5	Bit 4	Bit 3	Bit 2	Bit 1	Bit 0
Bank 1	0X05	LCDCR	LCDEN	LCDTYPE	BS1	BS0	DS1	DS0	LCDF1	LCDF0
			R/W	R/W	R/W	R/W	R/W	R/W	R/W	R/W
Bank 1	0X06	LCDAR	0	0	0	LCD_A4	LCD_A3	LCD_A2	LCD_A1	LCD_A0
						R/W	R/W	R/W	R/W	R/W
Bank 1	0X07	LCDBR	LCD_D7	LCD_D6	LCD_D5	LCD_D4	LCD_D3	LCD_D2	LCD_D1	LCD_D0
			R/W	R/W	R/W	R/W	R/W	R/W	R/W	R/W
Bank 1	0X08	LCDVCR	0	0	0	LCDC1	LCDC0	LCDVC2	LCDVC1	LCDVC0
						R/W	R/W	R/W	R/W	R/W
Bank 1	0X09	LCDCCR	CON7	CON6	CON5	CON4	CON3	CON2	CON1	CON0
			R/W	R/W	R/W	R/W	R/W	R/W	R/W	R/W
Bank 1	0X0A~0X0C	LCDSR0~2	SEG	SEG	SEG	SEG	SEG	SEG	SEG	SEG
			R/W	R/W	R/W	R/W	R/W	R/W	R/W	R/W

The EM78P510N can drive LCD, up to 23 segments and 8 commons that can drive 8×23 dots totally. LCD block is made up of LCD driver, display RAM, segment output pins, common output pins and LCD operating power supply pins. This circuit can work on normal mode, green mode and idle mode.

The LCD duty, bias, the number of segment, the number of common and frame frequency are determined by the LCD controller register.

The basic structure contains a timing control which use the main system clock or subsystem clock to generate the proper timing for different duty and display access. The R5 register is command register for LCD driver that include LCD enable/disable, bias (1/2, 1/3 and 1/4), duty (Static, 1/3, 1/4, 1/8) and LCD frame frequency control. The register bank 1 R6 is LCD RAM address control register. The register bank 1 R7 is LCD RAM data buffer. The register bank1 R8 is LCD contrast control and LCD clock register. The control register is explained below.

### 6.9.1 R5 LCDCR (LCD Control Register)

Bit 7	Bit 6	Bit 5	Bit 4	Bit 3	Bit 2	Bit 1	Bit 0
LCDEN	LCDDTYPE	BS1	BS0	DS1	DS0	LCDF1	LCDF0

**Bit 7 (LCDEN):** LCD Enable Select Bit

**0** : disable LCD Circuit. All common/segment outputs are set to VDD Level.

**1** : enable LCD circuit

**Bit 6 (LCDDTYPE):** LCD Drive Waveform Type Select Bit

**0** : A type wave

**1** : B type wave

**Bits 5~4 (BS1~BS0):** LCD Bias Select Bits

BS1	BS0	LCD Bias Select
0	0	1/2 Bias
0	1	1/3 Bias
1	X	1/4 Bias

**Bits 3~2 (DS1~DS0):** LCD Duty Select Bits

DS1	DS0	LCD Duty
0	0	Static
0	1	1/3 Duty
1	0	1/4 Duty
1	1	1/8 Duty



Bits 1~0 (LCDF1~LCDF0): LCD Frame Frequency Control Bits

LCD Frame Frequency (e.g. $F_s = 32.768K$ )					
LCDF1	LCDF0	Static	1/3 Duty	1/4 Duty	1/8 Duty
0	0	$F_s/(512*1) = 64.0$	$F_s/(172*3) = 63.5$	$F_s/(128*4) = 64$	$F_s/(64*8) = 64.0$
0	1	$F_s/(560*1) = 58.5$	$F_s/(188*3) = 58$	$F_s/(140*4) = 58.5$	$F_s/(70*8) = 58.5$
1	0	$F_s/(608*1) = 53.9$	$F_s/(204*3) = 53.5$	$F_s/(152*4) = 53.9$	$F_s/(76*8) = 53.9$
1	1	$F_s/(464*1) = 70.6$	$F_s/(156*3) = 70$	$F_s/(116*4) = 70.6$	$F_s/(58*8) = 70.6$

### 6.9.2 R6 LCDADDR (LCD Address Register)

Bit 7	Bit 6	Bit 5	Bit 4	Bit 3	Bit 2	Bit 1	Bit 0
0	0	0	LCD_A4	LCD_A3	LCD_A2	LCD_A1	LCD_A0

Bits 7~5: Reserved

Bits 4~0 (LCD\_A4~LCD\_A0): LCD RAM Address

R6 (LCD address)	R7 (LCD data buffer)								Segment
	Bit 7 (LCD_D7)	Bit 6 (LCD_D6)	Bit 5 (LCD_D5)	Bit 4 (LCD_D4)	Bit 3 (LCD_D3)	Bit 2 (LCD_D2)	Bit 1 (LCD_D1)	Bit 0 (LCD_D0)	
00H									SEG0
01H									SEG1
02H									SEG2
14H									SEG20
15H									SEG21
16H									SEG22
Common	COM7	COM6	COM5	COM4	COM3	COM2	COM1	COM0	

### 6.9.3 R7 LCDBR (LCD Data Buffer)

Bit 7	Bit 6	Bit 5	Bit 4	Bit 3	Bit 2	Bit 1	Bit 0
LCD_D 7	LCD_D 6	LCD_D 5	LCD_D 4	LCD_D 3	LCD_D 2	LCD_D 1	LCD_D 0

**Bits 7~0 (LCD\_D7~LCD\_D0):** LCD RAM Data Transfer Register

\* When the value of the display segment is “1”, the LCD display is turned on; when the bit value is “0”, the display is turned off

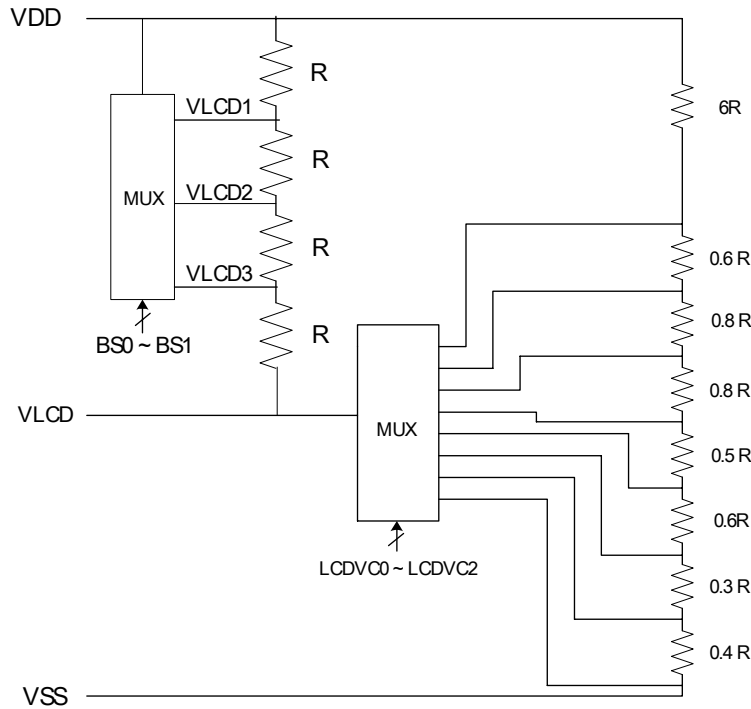

### 6.9.4 R8 LCDVCR (LCD Voltage Control Register)

Bit 7	Bit 6	Bit 5	Bit 4	Bit 3	Bit 2	Bit 1	Bit 0
0	0	0	LCDC1	LCDC0	LCDVC2	LCDVC1	LCDVC0

**Bits 7~5:** Reserved

**Bits 4~3 (LCDC1~LCDC0):** LCD Clock

LCDC1	LCDC0	F <sub>m</sub>	F <sub>LCd</sub>
0	0	16M	F <sub>c</sub> /2 <sup>9</sup>
0	1	8M	F <sub>c</sub> /2 <sup>8</sup>
1	0	4M	F <sub>c</sub> /2 <sup>7</sup>
1	1	2M	F <sub>c</sub> /2 <sup>6</sup>

When the main oscillator operates in crystal mode and there is no sub-oscillator, it is a must to set these two bits used for LCD clock.



Bit 2-0 (LCDVC2-LCDVC0): LCD Voltage Control Bits

LCDVC2	LCDVC1	LCDVC0	Output
0	0	0	0.4VDD ~ VDD
0	0	1	0.34VDD ~ VDD
0	1	0	0.26VDD ~ VDD
0	1	1	0.18VDD ~ VDD
1	0	0	0.13VDD ~ VDD
1	0	1	0.07VDD ~ VDD
1	1	0	0.04VDD ~ VDD
1	1	1	0V ~ VDD

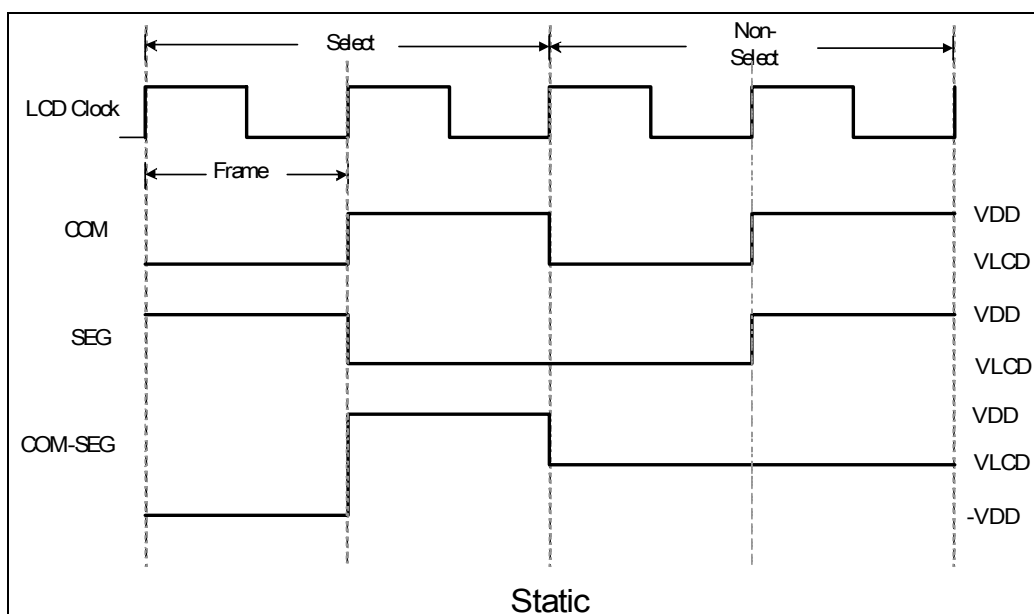

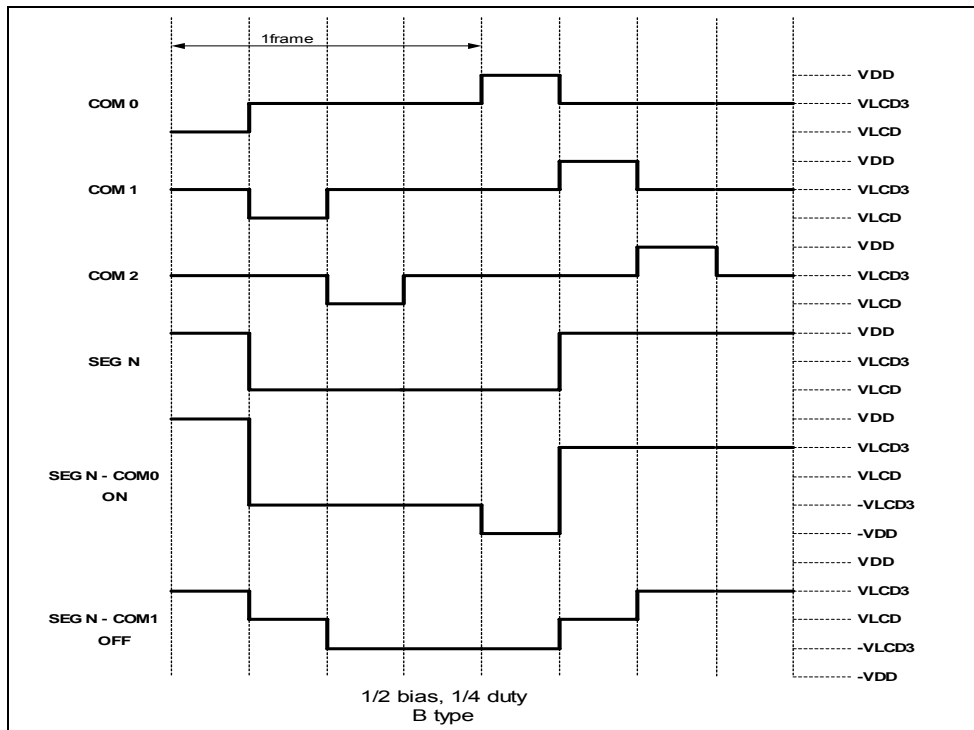
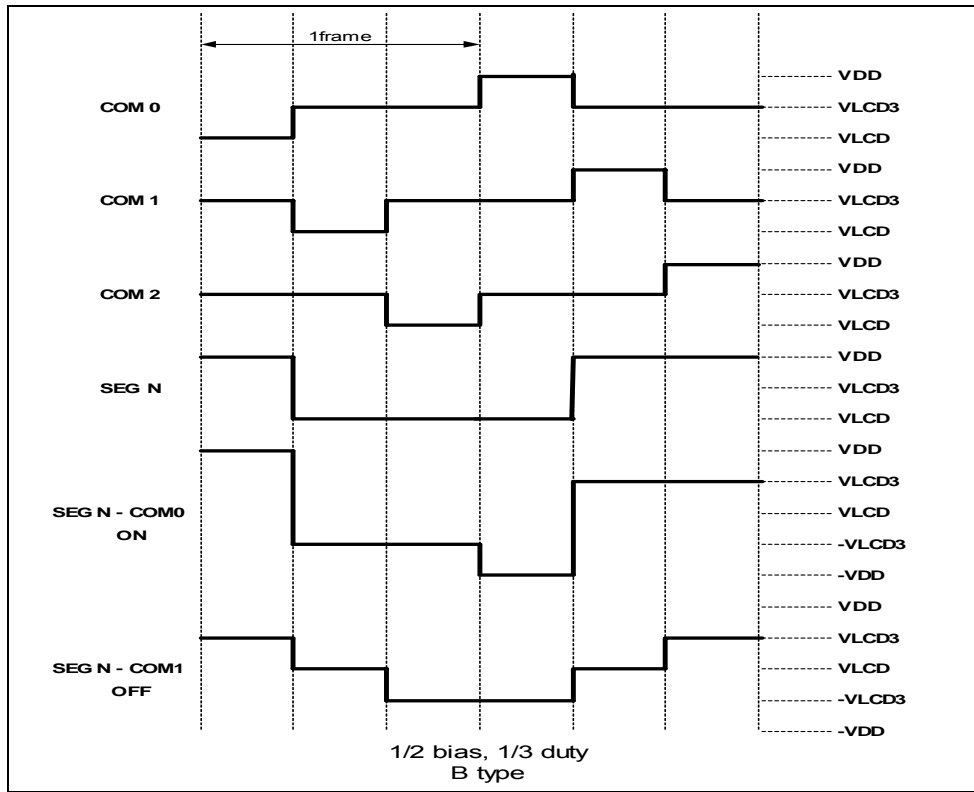

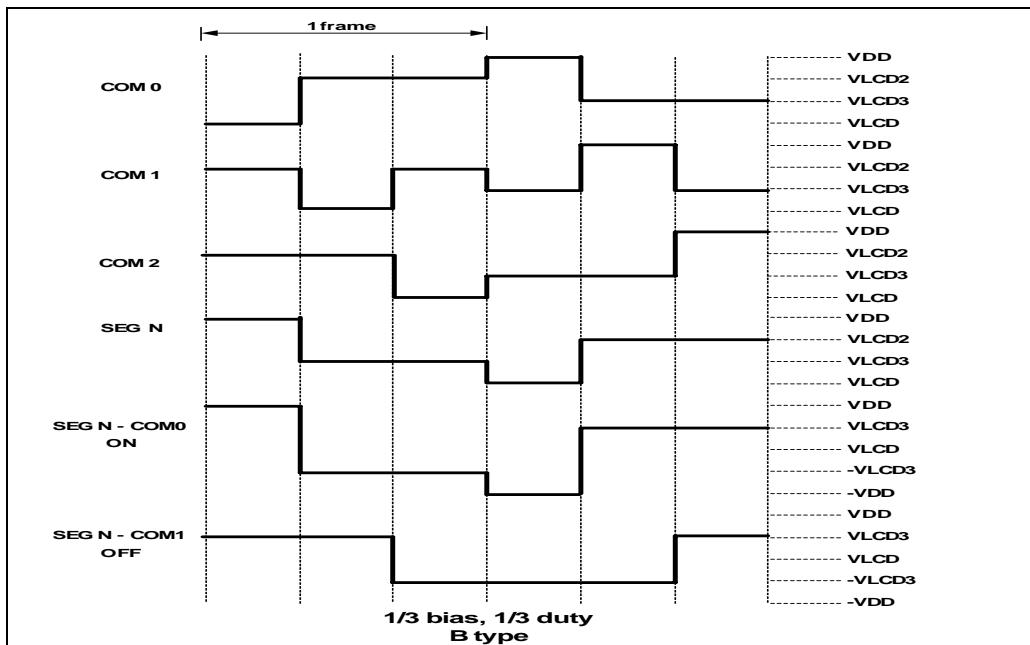
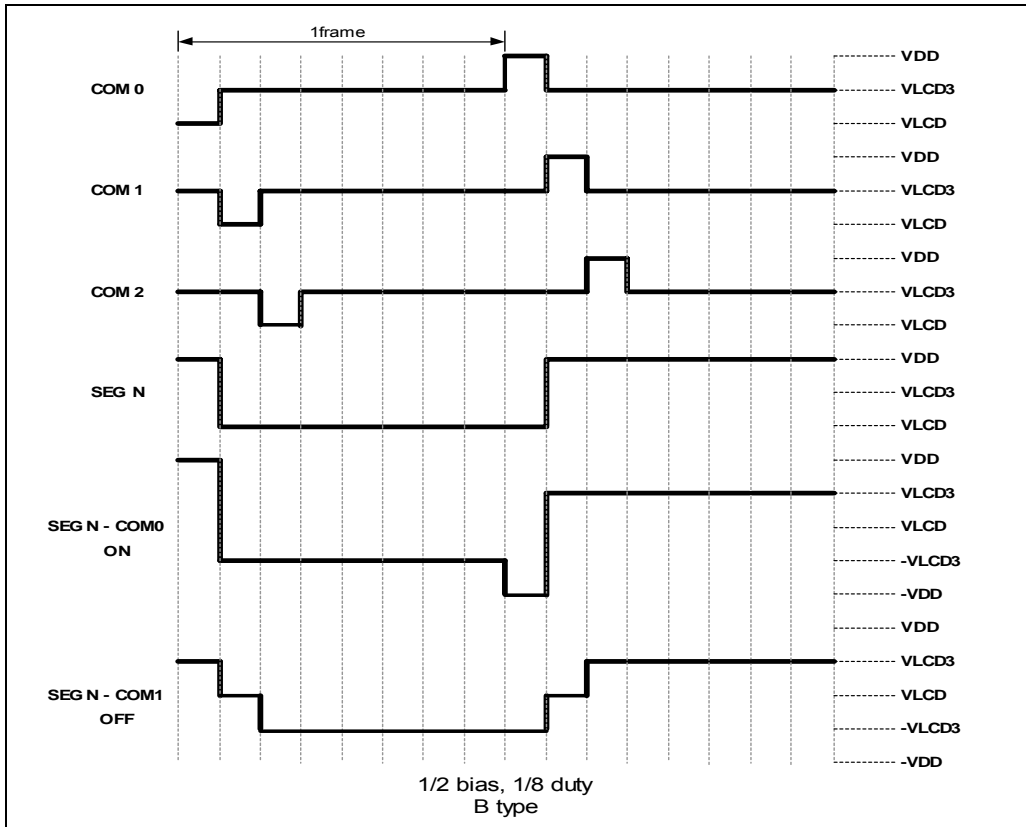

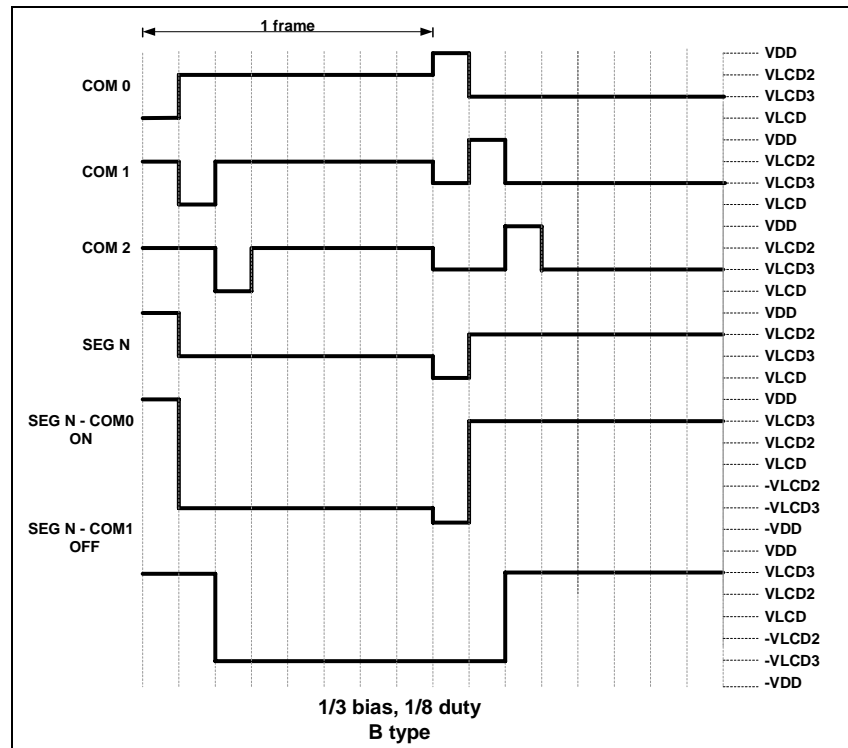
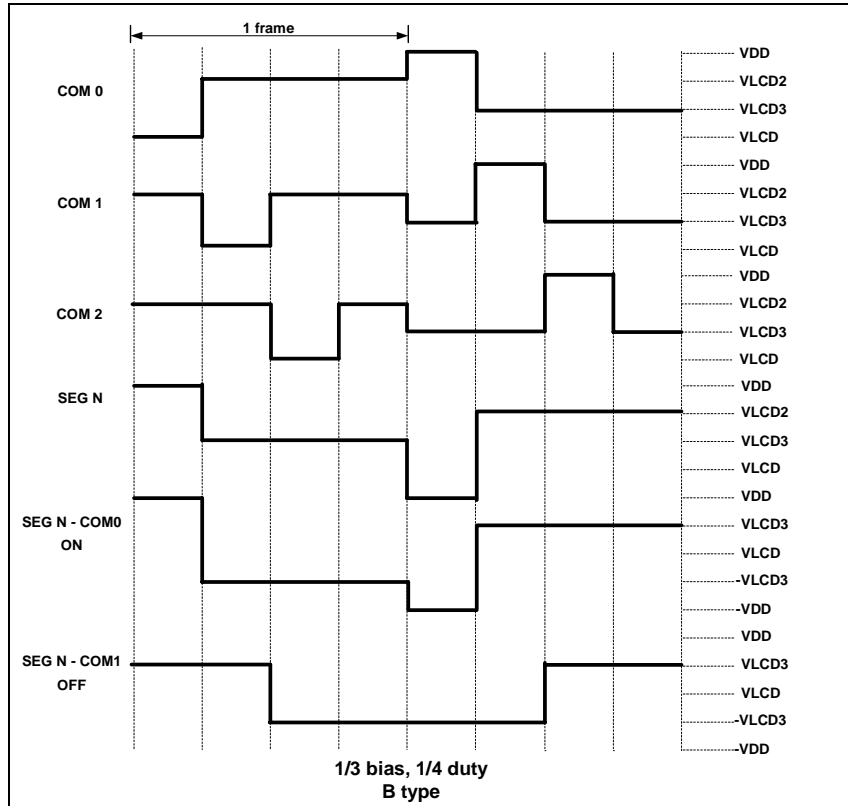

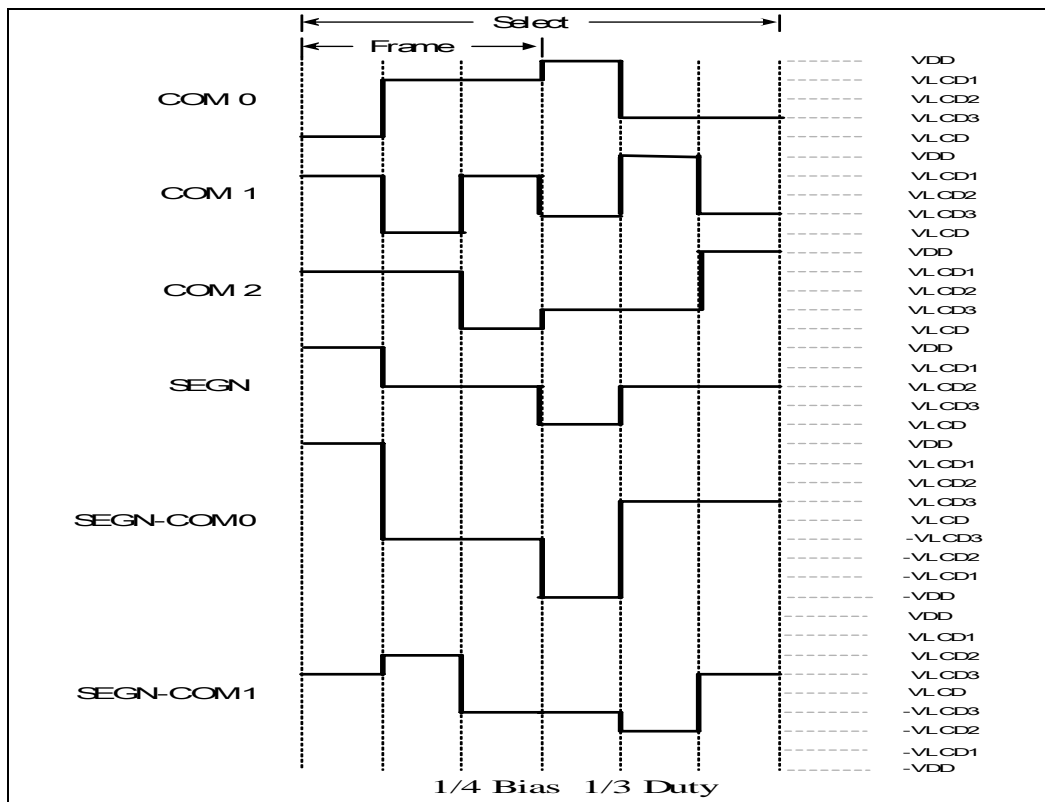

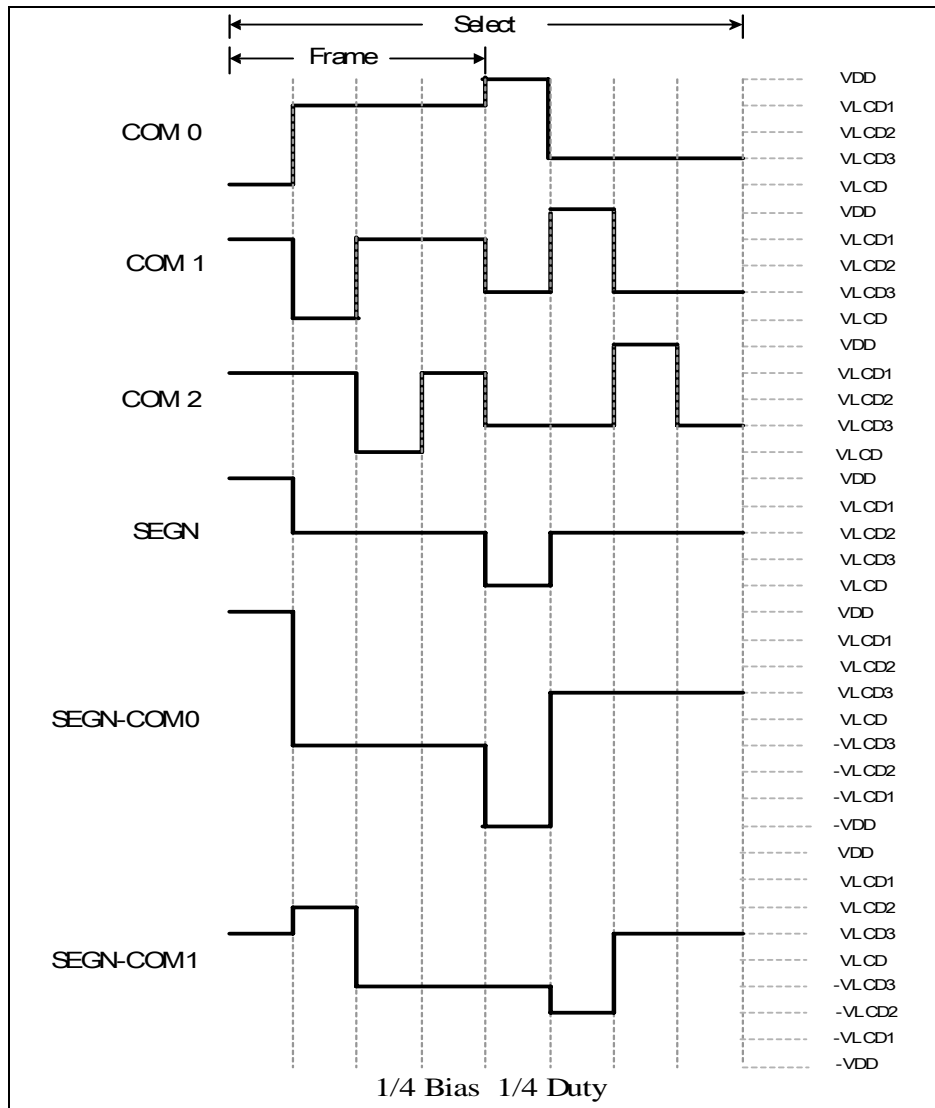

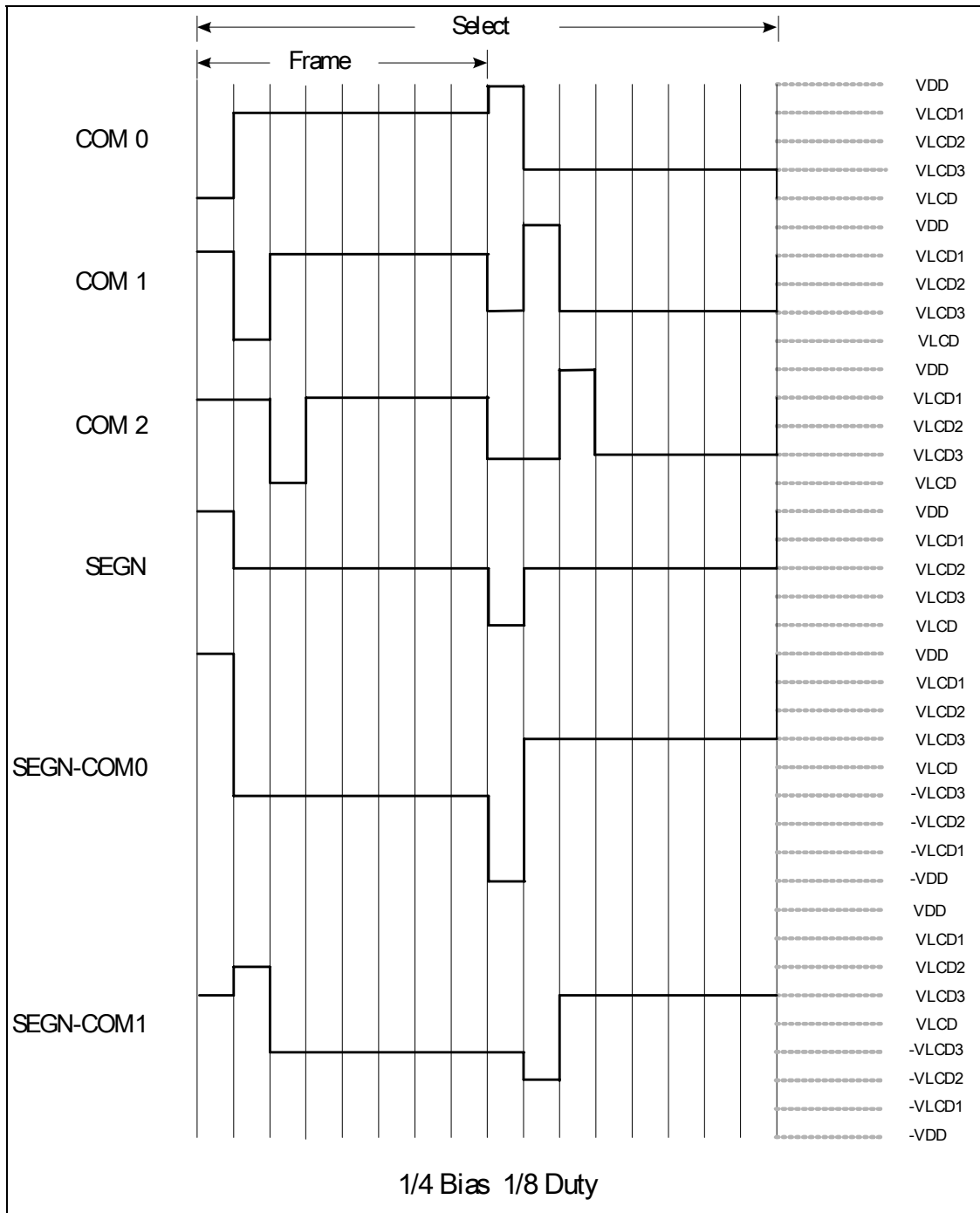

## 6.10 A/D Converter

Registers for AD Converter Circuit

R_BANK	Address	NAME	Bit 7	Bit 6	Bit 5	Bit 4	Bit 3	Bit 2	Bit 1	Bit 0
Bank 3	0X09	ADCR	ADRUN	ADP	ADCK1	ADCK0	ADIS3	ADIS2	ADIS1	ADIS0
			R/W	R/W	R/W	R/W	R/W	R/W	R/W	R/W
Bank 3	0x0A	ADICH	CALI	ADREF			ADE11	ADE10	ADE9	ADE8
			R/W	R/W			R/W	R/W	R/W	R/W
Bank 3	0X0B	ADICL	ADE7	ADE6	ADE5	ADE4	ADE3	ADE2	ADE1	ADE0
			R/W	R/W	R/W	R/W	R/W	R/W	R/W	R/W
Bank 3	0X0C	ADDH	ADD11	ADD10	ADD9	ADD8	ADD7	ADD6	ADD5	ADD4
			R	R	R	R	R	R	R	R
Bank 3	0X0D	ADDL	SIGN	VOF[2]	VOF[1]	VOF[0]	ADD3	ADD2	ADD1	ADD0
			R/W	R/W	R/W	R/W	R	R	R	R
Bank 0	0x0F	EIESL				ADWK	INTWK	INTWK	EIES9	EIES8
						R/W	R/W	R/W	R/W	R/W
Bank 0	0x0E	IMR	T1IE	LVDIE	ADIE	SPIIE	URTIE	EXIE9	EXIE8	TCIE
			R/W	R/W	R/W	R/W	R/W	R/W	R/W	R/W
Bank 0	0x0F	ISR	T1IF	LVDIF	ADIF	SPIIF	URTIF	EXIF9	EXIF8	TCIF
			R/W	R/W	R/W	R/W	R/W	R/W	R/W	R/W

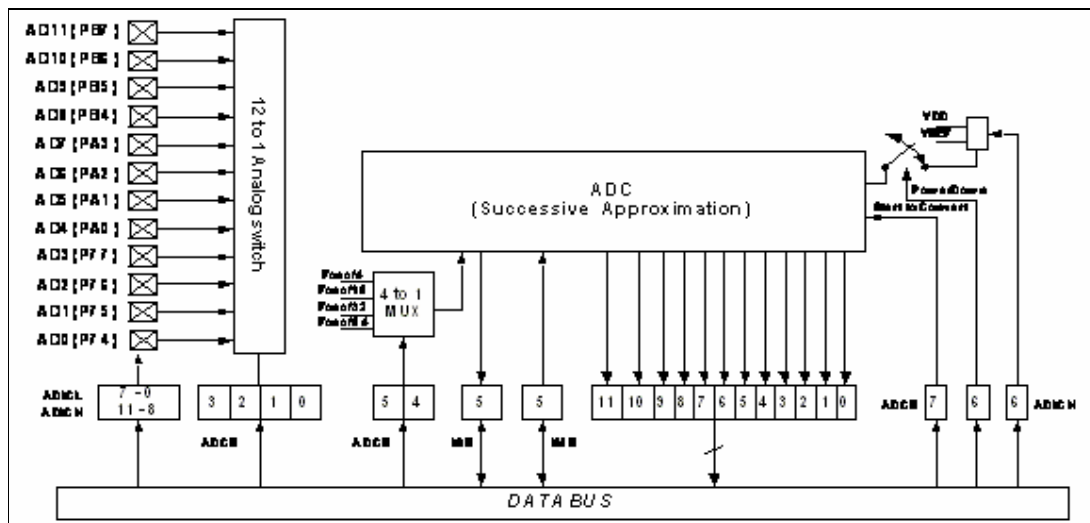

Fig. 6-16 AD Converter

This is a 12-bit successive approximation type AD converter. The upper side of analog reference voltage can select either internal VDD or external input pin P84 (VREF) by setting the ADREF bit in ADICH. Connecting to external VREF is more accuracy than internal VDD.



### **6.10.1 ADC Data Register**

When the A/D conversion is completed, the result is loaded to the ADDH (8-bit) and ADDL (4-bit). The START/END bit is cleared, and the ADIF is set.

### **6.10.2 A/D Sampling Time**

The accuracy, linearity, and speed of the successive approximation A/D converter are dependent on the properties of the ADC. The source impedance and the internal sampling impedance directly affect the time required to charge the sample holding capacitor. The application program controls the length of the sample time to meet the specified accuracy. Generally speaking, the program should wait for 2  $\mu$ s for each K $\Omega$  of the analog source impedance and at least 2  $\mu$ s for the low-impedance source. The maximum recommended impedance for the analog source is 10K $\Omega$  at VDD =5V. After the analog input channel is selected, this acquisition time must be done before A/D conversion can be started.

### **6.10.3 A/D Conversion Time**

ADCK0 and ADCK1 select the conversion time (Tct), in terms of instruction cycles. This allows the MCU to run at maximum frequency without sacrificing accuracy of A/D conversion. For the EM78P510N, the conversion time per bit is about 4 $\mu$ s. Table 8 shows the relationship between Tct and the maximum operating frequencies.

Table 8

<b>ADCK1:0</b>	<b>Operation Mode</b>	<b>Max. Frequency (Fc)</b>	<b>Max. Conversion Rate per Bit</b>	<b>Max. Conversion Rate</b>
0 0	Fc/4	1MHz	250kHz (4 $\mu$ s)	60us(16.66kHz)
0 1	Fc/16	4MHz	250kHz (4 $\mu$ s)	60us(16.66kHz)
1 0	Fc/32	8MHz	250kHz (4 $\mu$ s)	60us(16.66kHz)
1 1	Fc/64	16MHz	250kHz (4 $\mu$ s)	60us(16.66kHz)

## 6.11 UART (Universal Asynchronous Receiver/Transmitter)

Registers for UART Circuit

R_BANK	Address	NAME	Bit 7	Bit 6	Bit 5	Bit 4	Bit 3	Bit 2	Bit 1	Bit 0
Bank 3	0X05	URC	URTD8	UMODE1	UMODE0	BRATE2	BRATE1	BRATE0	UTBE	TXE
			W	R/W	R/W	R/W	R/W	R/W	R	R/W
Bank 3	0X06	URS	URRD8	EVEN	PRE	PRERR	OVERR	FMERR	URBF	RXE
			R	R/W	R/W	R	R	R	R	R/W
Bank 3	0X07	URRD	URRD7	URRD6	URRD5	URRD4	URRD3	URRD2	URRD1	URRD0
			R	R	R	R	R	R	R	R
Bank 3	0X08	URTD	URTD 7	URTD 6	URTD 5	URTD 4	URTD 3	URTD 2	URTD 1	URTD0
			W	W	W	W	W	W	W	W
Bank 5	0x06	UARC2			UARTE		UINVEN			
					R/W		R/W			
Bank 0	0x0E	IMR	T1IE	LVDIE	ADIE	SPIIE	URTIE	EXIE9	EXIE8	TCIE
			R/W	R/W	R/W	R/W	R/W	R/W	R/W	R/W
Bank 0	0x0F	ISR	T1IF	LVDIF	ADIF	SPIIF	URTIF	EXIF9	EXIF8	TCIF
			R/W	R/W	R/W	R/W	R/W	R/W	R/W	R/W

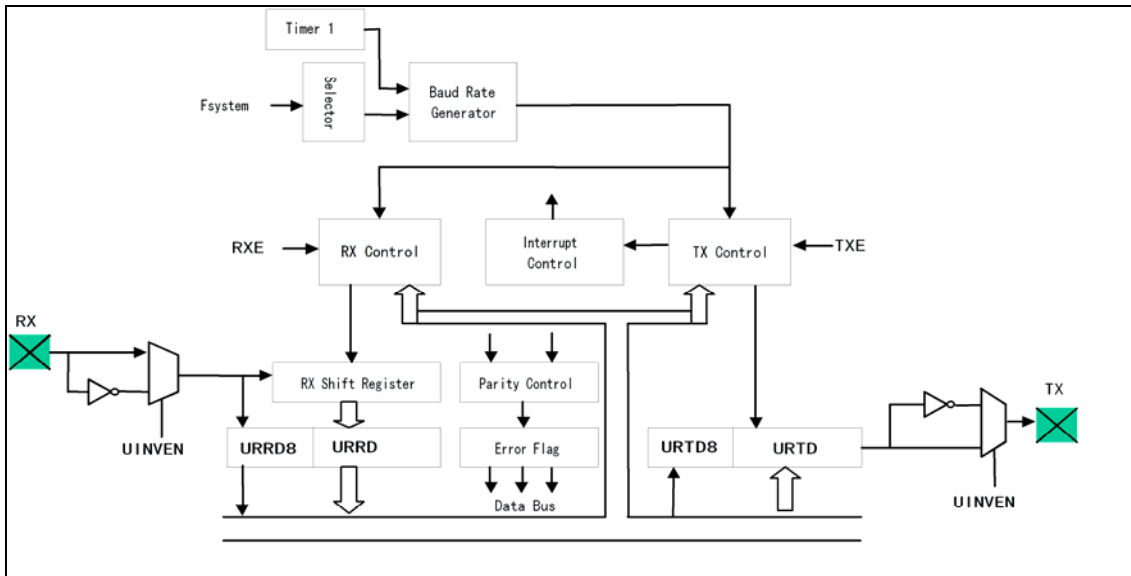

Fig 6-17 Function Block Diagram

In Universal Asynchronous Receiver Transmitter (UART), each transmitted or received character is individually synchronized by framing it with a start bit and stop bit.

Full duplex data transfer is possible since the UART has independent transmit and receive sections. Double buffering for both sections allows the UART to be programmed for continuous data transfer.



The figure below shows the general format of one character sent or received. The communication channel is normally held in the marked state (high). Character transmission or reception starts with a transition to the space state (low).

The first bit transmitted or received is the start bit (low). It is followed by the data bits, in which the least significant bit (LSB) comes first. The data bits are followed by the parity bit. If present, then the stop bit or bits (high) confirm the end of the frame.

In receiving, the UART synchronizes on the falling edge of the start bit. When two or three "0" are detected during three samples, it is recognized as normal start bit and the receiving operation is started.

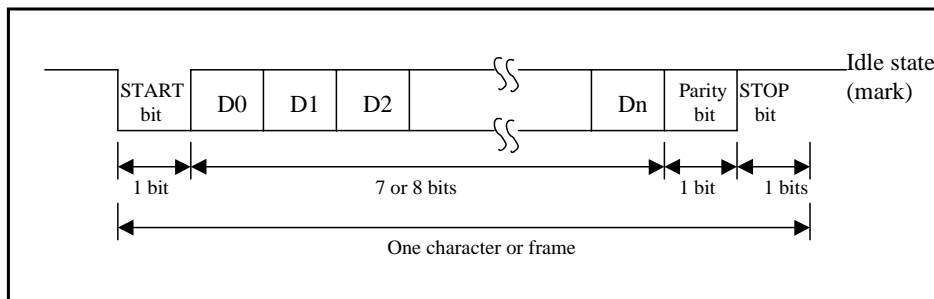

Fig 6-18 Data Format in UART

### 6.11.1 UART Mode

There are three UART modes. Mode 1 (7 bits data) and Mode 2 (8 bits data) allow the addition of a parity bit. The parity bit addition is not available in Mode 3. Figure 6-19 below shows the data format in each mode.

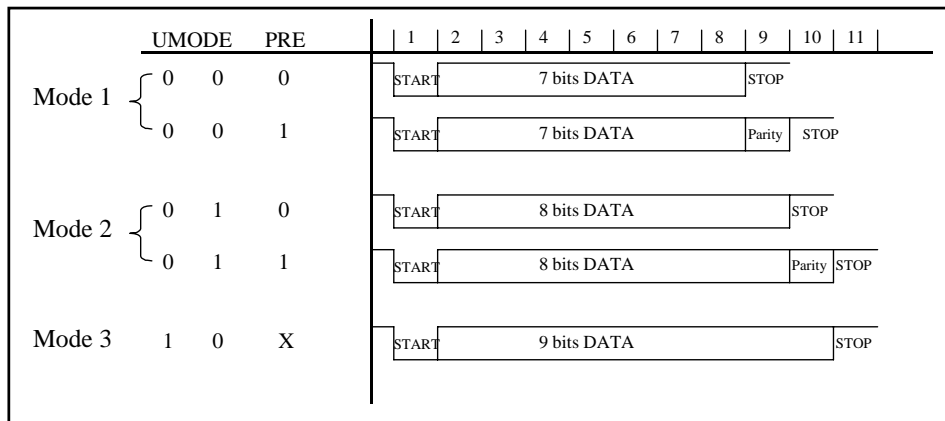

Fig 6-19 UART Model

### **6.11.2 Transmitting**

In transmitting serial data, the UART operates as follows:

1. Set the TXE bit of the URC register to enable the UART transmission function.
2. Write data into the URTD register and the UTBE bit of the URC register will be set by hardware.
3. Then start transmitting.
4. Serially transmitted data are transmitted in the following order from the TX pin.
5. Start bit: one “0” bit is output.
6. Transmit data: 7, 8 or 9 bits data are output from the LSB to the MSB.
7. Parity bit: one parity bit (odd or even selectable) is output.
8. Stop bit: one “1” bit (stop bit) is output.

Mark state: output “1” continues until the start bit of the next transmitted data.

After transmitting the stop bit, the UART generates a TBEF interrupt (if enabled).

### **6.11.3 Receiving**

In receiving, the UART operates as follows:

1. Set RXE bit of the URS register to enable the UART receiving function. The UART monitors the RX pin and synchronizes internally when it detects a start bit.
2. Receive data is shifted into the URRD register in the order from LSB to MSB.
3. The parity bit and the stop bit are received. After one character is received, the URBF bit of the URS register will be set to 1. This means UART interrupt will occur.
4. The UART makes the following checks:
  - (a) Parity check: The number of 1 of the received data must match the even or odd parity setting of the EVEN bit in the URS register.
  - (b) Frame check: The start bit must be 0 and the stop bit must be 1.
  - (c) Overrun check: The URBF bit of the URS register must be cleared (that means the URRD register should be read out) before the next received data is loaded into the URRD register.

If any checks failed, the URTIF interrupt will be generated (if enabled), and an error flag is indicated in PRERR, OVERR or FMERR bit. The error flag should be cleared by software otherwise, URTIF interrupt will occur when the next byte is received.

5. Read received data from URRD register. And URBF bit will be cleared by hardware.



**6.11.4 Baud Rate Generator**

The baud rate generator is comprised of a circuit that generates a clock pulse to determine the transfer speed for transmission/reception in the UART.

The BRATE2~BRATE0 bits of the URC register can determine the desired baud rate.

**6.11.5 UART Timing**

1. Transmission Counter Timing:

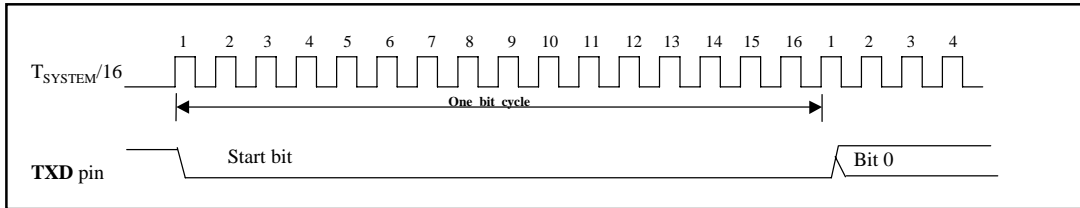

2. Receiving Counter Timing:

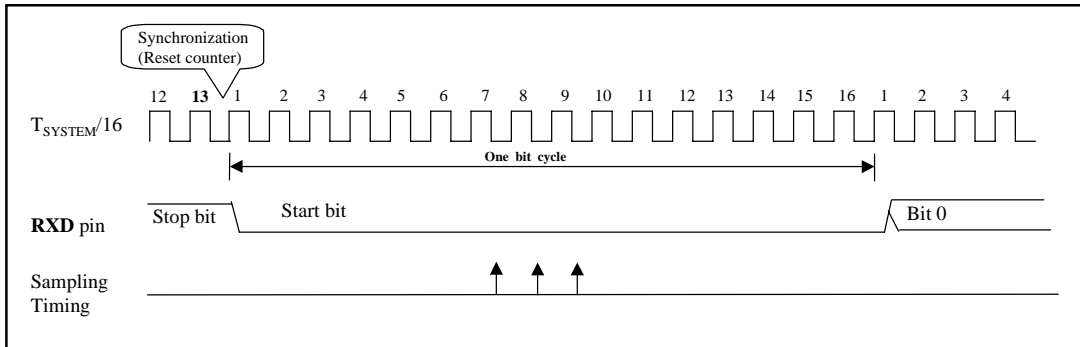

3. UART Transmit operation (8 bits data with parity bit):

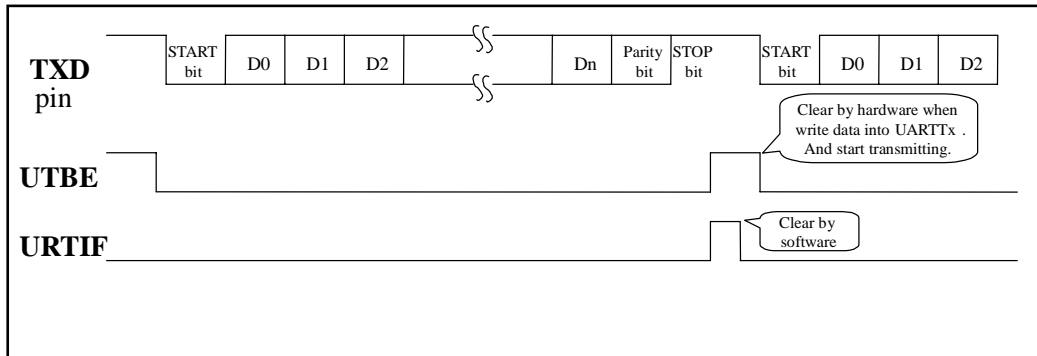

4. UART Receive operation (8 bits data with parity and stop bit):

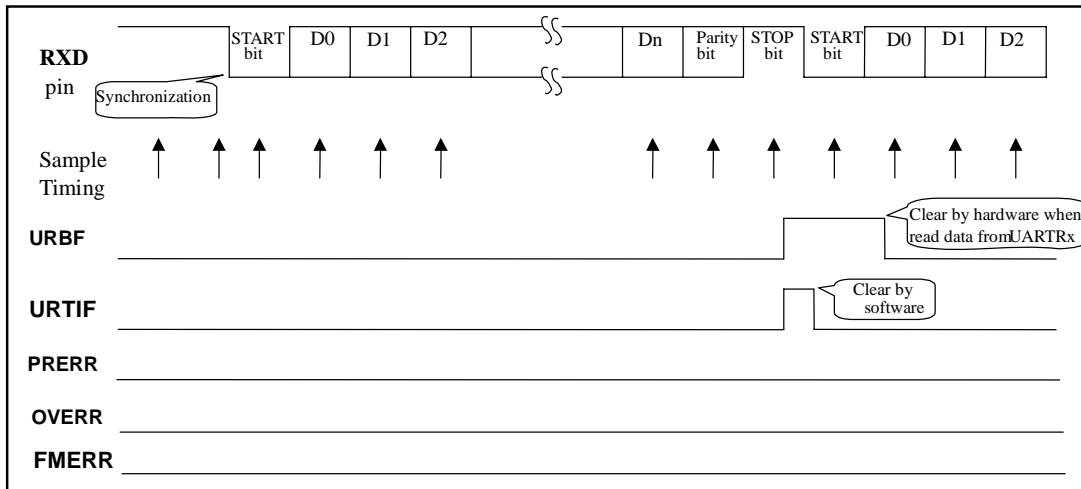

## 6.12 SPI (Serial Peripheral Interface)

### 6.12.1 Overview & Features

#### Overview:

Figures 6-20 and 6-21 shows how the EM78P510N communicates with other devices through SPI module. If the EM78P510N is a master controller, it sends clock through the SCK pin. A couple of 8-bit data are transmitted and received at the same time. However, if the EM78P510N is defined as a slave, its SCK pin could be programmed as an input pin. Data will continue to be shifted based on both the clock rate and the selected edge. You can also set SPIS bit 7 (DORD) to determine the SPI transmission order, SPIC Bit 3 (SDOC) to control the SO pin after serial data output status and SPIS Bit 6 (TD1), Bit 5 (TD0) determines the SO status output delay times.

#### Features:

- Operation in either Master mode or Slave mode
- Full duplex, three-wire synchronous communication
- Programmable baud rates of communication
- Programming clock polarity, (RD Bit 7)
- Interrupt flag available for the read buffer full
- SPI transmission order
- After serial data output SDO status select
- SDO status output delay times
- Up to 8 MHz (maximum) bit frequency

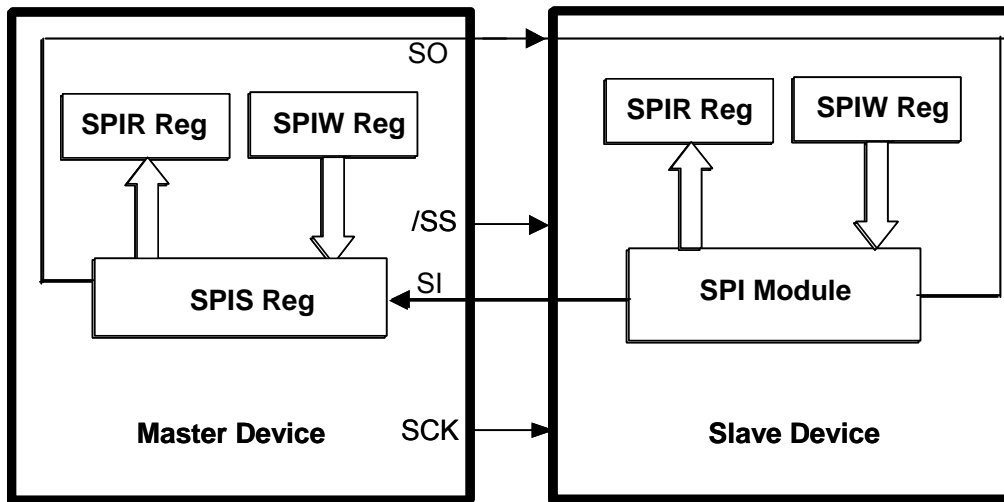

Fig. 6-20 SPI Master/Slave Communication

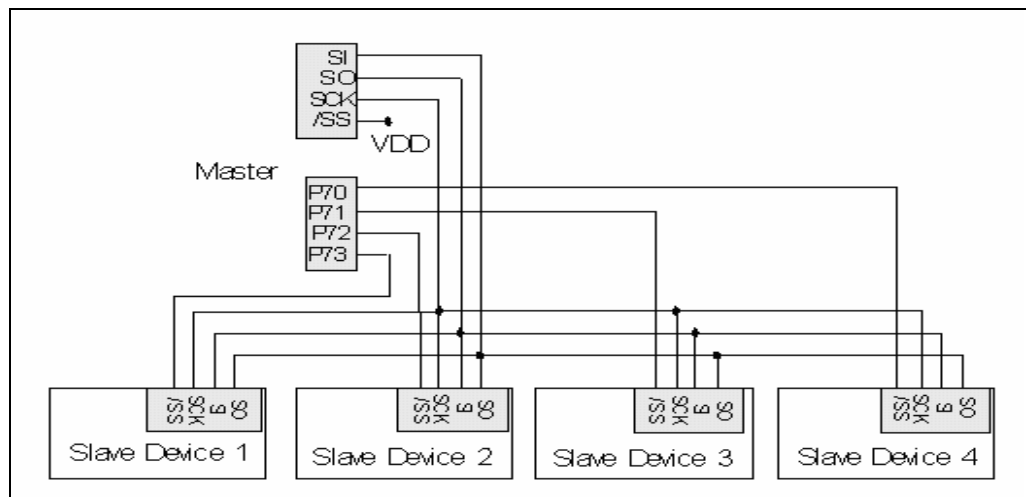

Fig. 6-21 SPI Configuration of Single-Master and Multi-Slave





Below are the functions of each block and explanations on how to carry out the SPI communication with the signals depicted in Fig.6-22 and Fig.6-23.

- PA4/SEG4/SI:Serial Data In
- PA5/SEG5/SO:Serial Data Out
- PA6/SEG6/SCK:Serial Clock
- PA7/SEG7//SS:/Slave Select (Option). This pin (/SS) may be required during a slave mode
- RBF: Set by Buffer Full Detector
- Buffer Full Detector: Set to 1 when an 8-bit shifting is completed.
- SSE: Loads the data in SPIS register, and begin to shift
- SPIS reg.:Shifting byte in and out. The MSB is shifted first. Both the SPIR and the SPIW registers are shift at the same time. Once data are written, SPIS starts transmission / reception. The data received will be moved to the SPIR register as the shifting of the 8-bit data is completed. The RBF (Read Buffer Full) flag and the SPIIF (SPI Interrupt) flag are then set.
- SPIR reg.:Read buffer. The buffer will be updated as the 8-bit shifting is completed. The data must be read before the next reception is completed. The RBF flag is cleared as the SPIR register reads.
- SPIW reg.:Write buffer. The buffer will deny any attempts to write until the 8-bit shifting is completed.

The SSE bit will be kept in “1” if the communication is still undergoing. This flag must be cleared as the shifting is completed. Users can determine if the next write attempt is available.

- SBRS2~SBRS0: Programming the clock frequency/rates and sources.
- Clock Select:Selecting either the internal or the external clock as the shifting clock.
- Edge Select:Selecting the appropriate clock edges by programming the CES bit

### **6.12.3 SPI Signal & Pin Description**

The detailed functions of the four pins, SI, SO, SCK, and /SS are as follows:

#### **PA4/SEG4/SI:**

- Serial Data In,
- Receive sequentially, the Most Significant Bit (MSB) first, Least Significant Bit (LSB) last,
- Defined as high-impedance, if not selected



- Program the same clock rate and clock edge to latch on both the master and slave devices
- The byte received will update the transmitted byte
- The RBF (located in Register 0x0C) will be set as the SPI operation is completed
- Timing is shown in Fig.6-23 and 6-24

**PA5/SEG5/SO:**

- Serial Data Out
- Transmit sequentially; the Most Significant Bit (MSB) first, Least Significant Bit (LSB) last
- Program the same clock rate and clock edge to latch on both the master and slave devices
- The received byte will update the transmitted byte
- The CES (located in Register 0x0D) bit will be reset, as the SPI operation is completed
- Timing is shown in Fig.6-23 and 6-24

**PA6/SEG6/SCK:**

- Serial Clock
- Generated by a master device
- Synchronize the data communication on both the SI and SO pins
- The CES (located in Register 0x0D) is used to select the edge to communicate.
- The SBR0~SBR2 (located in Register 0x0D) is used to determine the baud rate of communication
- The CES, SBR0, SBR1, and SBR2 bits have no effect in slave mode
- Timing is show in Fig.6-23 and 6-24

**PA7/SEG7//SS:**

- Slave Select; negative logic
- Generated by a master device to signify the slave(s) to receive data
- Goes low before the first cycle of SCK appears, and remains low until the last (eighth) cycle is completed
- Ignores the data on the SI and SO pins while /SS is high, because the SO is no longer driven
- Timing is shown in Fig.6-23 and 6-24



**Note:**

1. The Priority of PA4/SEG4/SI Pin

PA4/SEG4/SI Pin Priority		
High	Medium	Low
SI	SEG4	PA4

2. The Priority of PA5/SEG5/SO Pin

PA5/SEG5/SO Pin Priority		
High	Medium	Low
SO	SEG5	PA5

3. The Priority of PA6/SEG6/SCK Pin

PA6/SEG6/SCK Pin Priority		
High	Medium	Low
SCK	SEG6	PA6

4. The Priority of PA7/SEG7//SS PIN

PA7/SEG7//SS Pin Priority		
High	Medium	Low
/SS	SEG7	PA7

### 6.12.4 Programming the Related Registers

Registers for the SPI Circuit

R_BANK	Address	Name	Bit 7	Bit 6	Bit 5	Bit 4	Bit 3	Bit 2	Bit 1	Bit 0
Bank 2	0X0C	SPIS	DORD	TD1	TD0	-	OD3	OD4	-	RBF
			R/W	R/W	R/W	-	R/W	R/W	-	R
Bank 2	0X0D	SPIC	CES	SPIE	SRO	SSE	SDOC	SBR2	SBR1	SBR0
			R/W	R/W	R/W	R/W	R/W	R/W	R/W	R/W
Bank 2	0X0E	SPIR	SRB7	SRB6	SRB5	SRB4	SRB3	SRB2	SRB1	SRB0
			R/W	R/W	R/W	R/W	R/W	R/W	R/W	R/W
Bank 2	0X0F	SPIW	SWB7	SWB6	SWB5	SWB4	SWB3	SWB2	SWB1	SWB0
			R/W	R/W	R/W	R/W	R/W	R/W	R/W	R/W
BANK 0	0x0E	IMR	T1IE	LVDIE	ADIE	SPIIE	URTIE	EXIE9	EXIE8	TCIE
			R/W	R/W	R/W	R/W	R/W	R/W	R/W	R/W
Bank 0	0x0F	ISR	T1IF	LVDIF	ADIF	SPIIF	URTIF	EXIF9	EXIF8	TCIF
			R/W	R/W	R/W	R/W	R/W	R/W	R/W	R/W

As the SPI mode is defined, the related registers of this operation are shown.

Related Control Registers of the SPI Mode

Address	Name	Bit 7	Bit 6	Bit 5	Bit 4	Bit 3	Bit 2	Bit 1	Bit 0
Bank 2 0x0D	SPIC	CES	SPIE	SRO	SSE	SDOC	SBR2	SBR1	SBR0
Bank 0 0x0E	IMR	T1IE	LVDIE	ADIE	SPIIE	URTIE	EXIE9	EXIE8	TCIE

**SPIC:** SPI Control Register



**Bit 7 (CES):** Clock Edge Select Bit

**0 :** Data shifts out on a rising edge, and shifts in on a falling edge. Data is on hold during a low-level.

**1 :** Data shifts out on a falling edge, and shifts in on a rising edge. Data is on hold during a high-level.

**Bit 6 (SPIE):** SPI Enable Bit

**0 :** Disable SPI mode

**1 :** Enable SPI mode

**Bit 5 (SRO):** SPI Read Overflow Bit

**0 :** No overflow

**1 :** A new data is received while the previous data is still being held in the SPIRB register. In the situation, the data in SPIR register will be destroyed. To avoid setting this bit, users are required to read the SPIRB register although only the transmission is implemented. This can only occur in slave mode.

**Bit 4 (SSE):** SPI Shift Enable Bit

**0 :** Resets as soon as the shift is completed, and the next byte is read to shift.

**1 :** Starts to shift, and remained on “1” while the current byte is still being transmitted.

**Bit 3 (SDOC):** SDO Output Status Control Bit

**0 :** After the serial data output, the SDO remain high.

**1 :** After the serial data output, the SDO remain low.

**Bits 2~0 (SBRS2~SBRS0):** SPI Baud Rate Select Bits

SBRS2	SBRS1	SBRS0	Mode	SPI Baud Rate
0	0	0	Master	Fosc/2
0	0	1	Master	Fosc/4
0	1	0	Master	Fosc/8
0	1	1	Master	Fosc/16
1	0	0	Master	Fosc/32
1	0	1	Master	Timer2
1	1	0	Slave	/SS enable
1	1	1	Slave	/SS disable

**IMR:** Interrupt Mask Register



**Bit 4 (SPIIE):** Interrupt Enable Bit

**0 :** disable SPIIF interrupt

**1 :** enable SPIIF interrupt

Related Status/Data Registers of the SPI Mode

Address	Name	Bit 7	Bit 6	Bit 5	Bit 4	Bit 3	Bit 2	Bit 1	Bit 0
0X0C	SPIS	DORD	TD1	TD0	-	OD3	OD4	-	RBF
0x0E	SPIR	SRB7	SRB6	SRB5	SRB4	SRB3	SRB2	SRB1	SRB0
0x0F	SPIW	SWB7	SWB6	SWB5	SWB4	SWB3	SWB2	SWB1	SWB0

**SPIS:** SPI Status Register

**Bit 7 (DORD):** Data Shift Control Bit

**0 :** Shift left (MSB first)

**1 :** Shift right (LSB first).

**Bits 6~5 (TD1~TD0):** SDO Status Output Delay Times Options

TD1	TD0	Delay Time
0	0	8 CLK
0	1	16 CLK
1	0	24 CLK
1	1	32 CLK

**Bit 4:** Reserved

**Bit 3 (OD3):** Open-Drain Control Bit

**1 :** Open-drain enable for SDO

**0 :** Open-drain disable for SDO.

**Bit 2 (OD4):** Open-Drain Control Bit

**1 :** Open-drain enable for SCK

**0 :** Open-drain disable for SCK.

**Bit 1:** Reserved

**Bit 0 (RBF):** Read Buffer Full Flag

**1 :** Receiving completed, and SPIRB is fully exchanged.

**0 :** Receiving not completed, and SPIRB has not fully exchanged.

**SPIRB:** SPI Read Buffer. Once the serial data is received completely, it will load to SPIRB from SPIS register. The RBF bit in the SPIS register will also be set.

**SPIWB:** SPI Write Buffer. As a transmitted data is loaded, the SPIS register stands by and start to shift the data when sensing SCK edge with SSE set to "1".

### 6.12.5 SPI Mode Timing

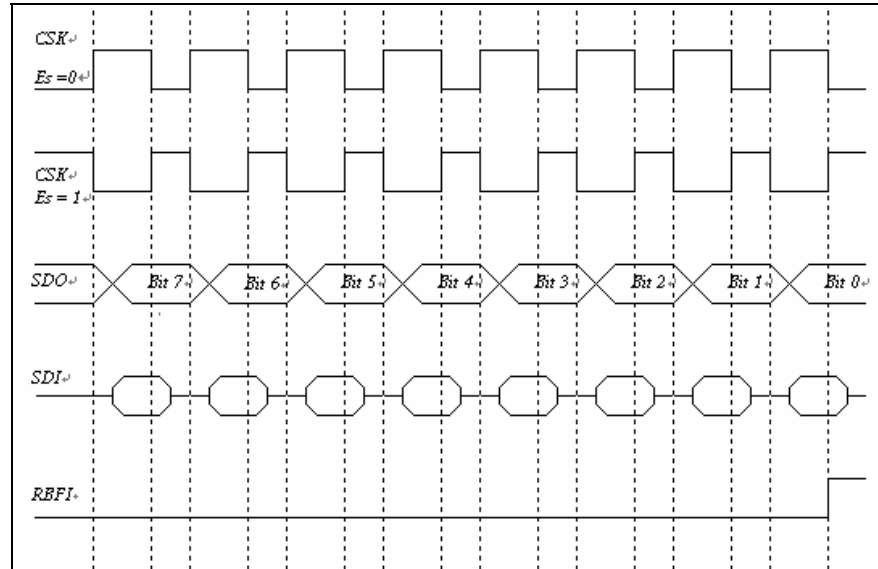

Fig. 6-24 SPI Mode with /SS Disabled

The SCK edge is selected by programming bit CES. The waveform shown in Fig.6-24 is applicable regardless of whether the EM78P510N is in master or slave mode with /SS disabled. However, the waveform in Fig.6-25 can only be implemented in slave mode with /SS enabled.

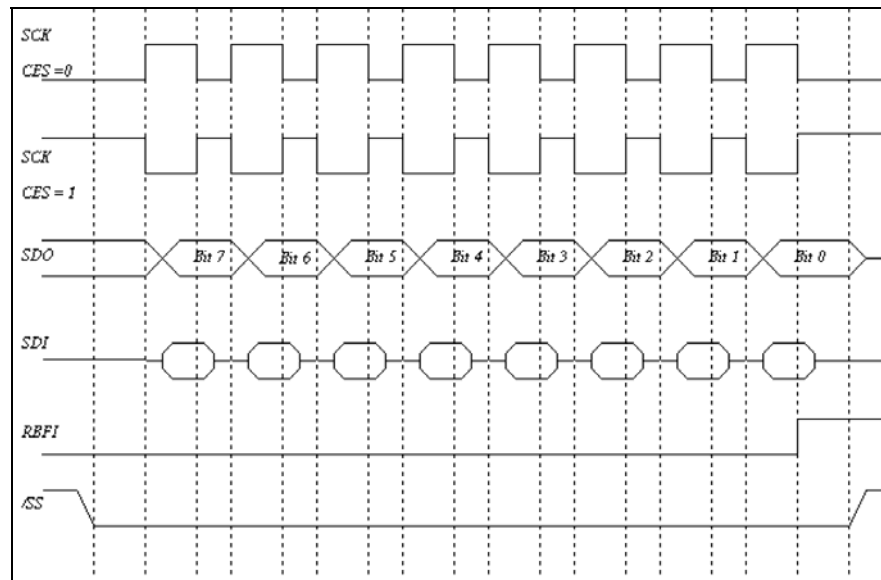

Fig. 6-25 SPI Mode with /SS Enabled



### 6.13 Timer/Counter 1

Registers for Timer/Counter 1 Circuit

R_BANK	Address	Name	Bit 7	Bit 6	Bit 5	Bit 4	Bit 3	Bit 2	Bit 1	Bit 0
Bank 2	0X05	T1CR	TIS1	TIS0	T1MS2	T1MS1	T1MS0	T1P2	T1P1	T1P0
			W	W	W	W	W	W	W	W
Bank 2	0X06	TSR	T1MOD	TRCB	T1CSS1	T1CSS0	T2CSS	T1S	T1OMS	T1OC
			R/W	R/W	R/W	R/W	R/W	R/W	R/W	R/W
Bank 2	0X07	T1PD	PRD1[7]	PRD1[6]	PRD1[5]	PRD1[4]	PRD1[3]	PRD1[2]	PRD1[1]	PRD1[0]
			R/W	R/W	R/W	R/W	R/W	R/W	R/W	R/W
Bank 2	0X08	T1TD	TD1[7]	TD1[6]	TD1[5]	TD1[4]	TD1[3]	TD1[2]	TD1[1]	TD1[0]
			R/W	R/W	R/W	R/W	R/W	R/W	R/W	R/W
Bank 0	0x0E	IMR	T1IE	LVDIE	ADIE	SPIIE	URTIE	EXIE9	EXIE8	TCIE
			R/W	R/W	R/W	R/W	R/W	R/W	R/W	R/W
Bank 0	0x0F	ISR	T1IF	LVDIF	ADIF	SPIIF	URTIF	EXIF9	EXIF8	TCIF
			R/W	R/W	R/W	R/W	R/W	R/W	R/W	R/W

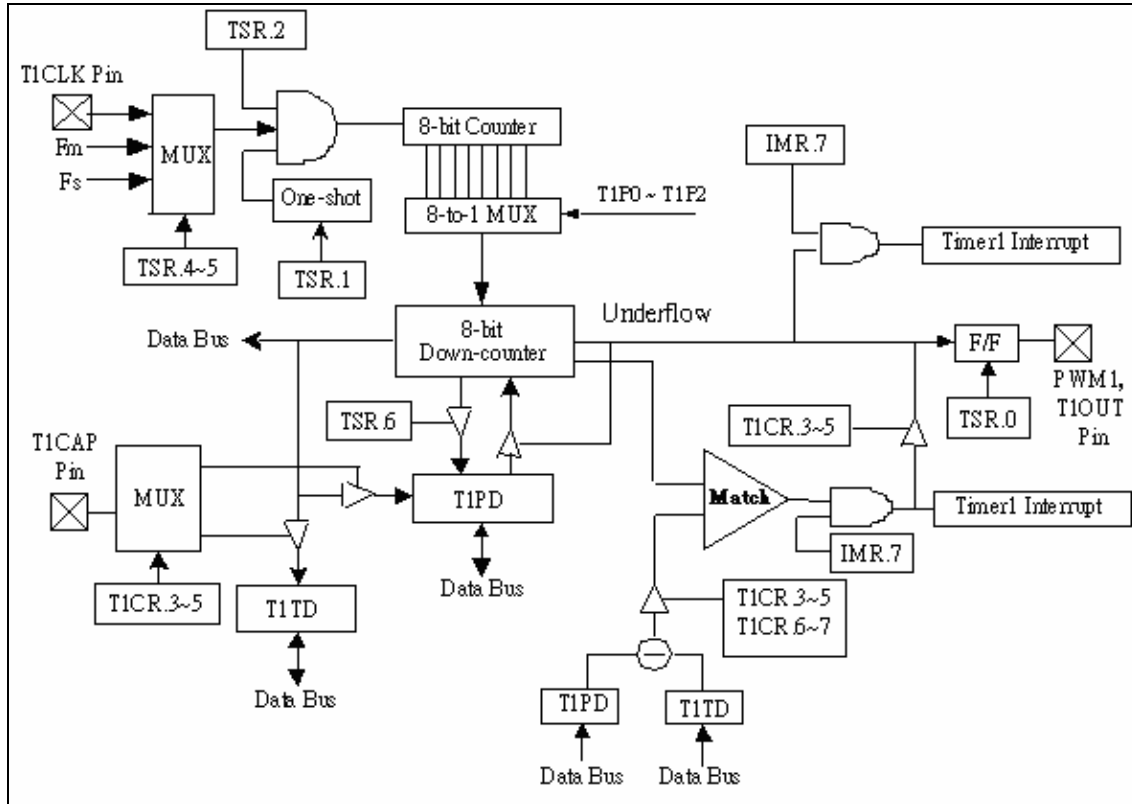

Fig. 6-26 Timer/Counter 1 Configuration

### 6.13.1 Timer Mode

In Timer mode, counting down is performed using the internal clock. The down-counter value auto reloads from T1PD. When the contents of the down-counter underflows, an interrupt is generated and the counter is cleared. Counting down resumes after the counter is cleared.

### 6.13.2 T1OUT Mode

In Timer 1 underflow Output mode, counting down is performed using the internal clock with prescaler or External clock through T1CLK Pin or Sub Frequency with prescaler. The counter value is loaded from T1PD, when the counter underflows. The F/F output is toggled and the counter is auto-reloaded from T1PD, each time an overflow is found. The F/F output is inverted and output to /T1OUT pin. This mode can generate 50% duty pulse output. The program can initialize the F/F and it is initialized to “0” during a reset. A T1OUT interrupt is generated each time the /T1OUT output is toggled.

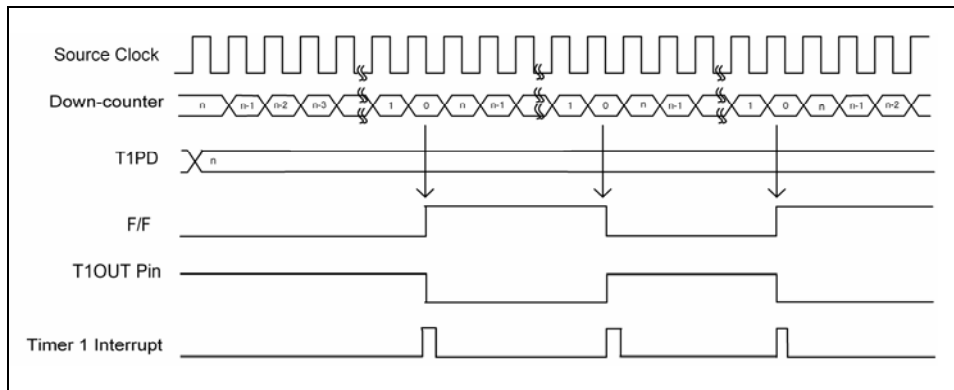

Fig 6-27 T1OUT Mode Timing Chart

### 6.13.3 Capture Mode

In Capture mode, the pulse width, period and duty of the T1CAP input pin are measured in this mode, which can be used in decoding the remote control signal. The counter is free running by the internal clock. On the rising (falling) edge of T1CAP pin input, the contents of the counter is loaded into T1PD, then the counter is cleared and interrupt is generated. On the falling (rising) edge of T1CAP pin input, the contents of the counter are loaded into T1TD. The counter is still counting, on the next rising edge of the T1CAP pin input, the contents of the counter are loaded into T1PD, counter is cleared and interrupt is generated again. If an overflow occurs before the edge is detected, the 00H is loaded into T1PD and an underflow interrupt is generated. During interrupt processing, it can be determined whether or not there is an overflow by checking whether the T1PD value is 00H. After an interrupt (capture to T1PD or overflow detection) is generated, capture and underflow detection are halted until T1PD is read out.

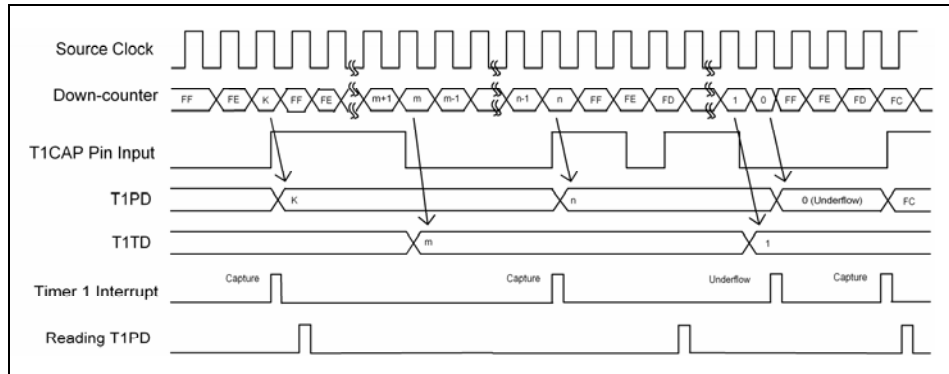

Fig 6-28 Capture Mode Timing Chart

### 6.13.4 PWM Mode

In Pulse Width Modulation (PWM) Output mode, counting down is performed using the internal clock with prescaler or external clock through T1CLK Pin or Sub Frequency with prescaler. The Duty of PWM1 control by T1TD, and the period of PWM1 control by T1PD. The pulse at the PWM1 pin is held to high level as long as the counter value of T1TD greater than or equal to zero, while the pulse is held to low level until the counter value of T1PD is underflow. The F/F is toggled when underflow. The counter is still counting, the F/F is toggled again when the counter underflows, then the counter is auto reload from T1PD. The F/F output is inverted and output to the /PWM pin. A Timer1 interrupt is generated each time an underflow occurs. T1PD is configured as a 2-stage shift register and, during output, will not switch until one output cycle is completed even if T1PD is overwritten. Therefore, the output can be changed continuously. T1PD is also shifted the first time by setting T1S to "1" after data is loaded to T1PD.

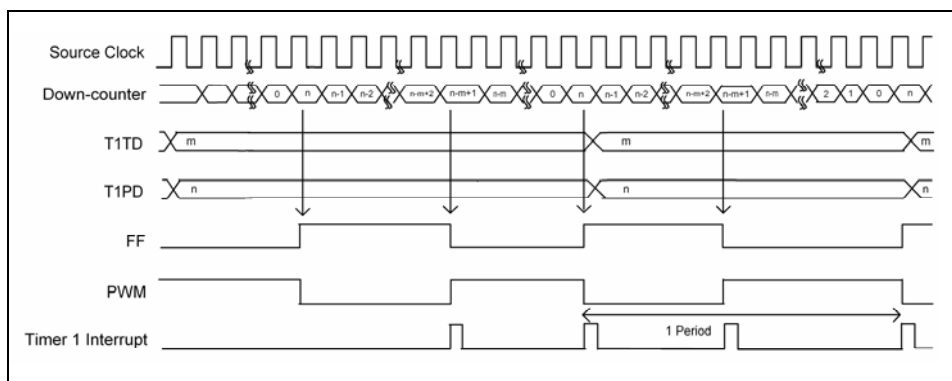

Fig 6-29 PWM Mode Timing Chart

### 6.13.5 16-Bit Mode

In 16-bit timer mode, all function in Timer 1 resolution become 16 bits.

## 6.14 Timer 2

Registers for Timer 2 Circuit

R_BANK	Address	NAME	Bit 7	Bit 6	Bit 5	Bit 4	Bit 3	Bit 2	Bit 1	Bit 0
Bank 2	0X06	TSR	T1MOD	TRCB	T1CSS1	T1CSS0	T2CSS	T1S	T1OMS	T1OC
			R/W	R/W	R/W	R/W	R/W	R/W	R/W	R/W
Bank 2	0X09	T2CR	T2IF	T2IE	T2S	T2MS1	T2MS0	T2P2	T2P1	T2P0
			R/W	R/W	R/W	R/W	R/W	R/W	R/W	R/W
Bank 2	0X0A	T2PD	PRD2[7]	PRD2[6]	PRD2[5]	PRD2[4]	PRD2[3]	PRD2[2]	PRD2[1]	PRD2[0]
			R/W	R/W	R/W	R/W	R/W	R/W	R/W	R/W
Bank 2	0X0B	T2TD	TD2[7]	TD2[6]	TD2[5]	TD2[4]	TD2[3]	TD2[2]	TD2[1]	TD2[0]
			R/W	R/W	R/W	R/W	R/W	R/W	R/W	R/W

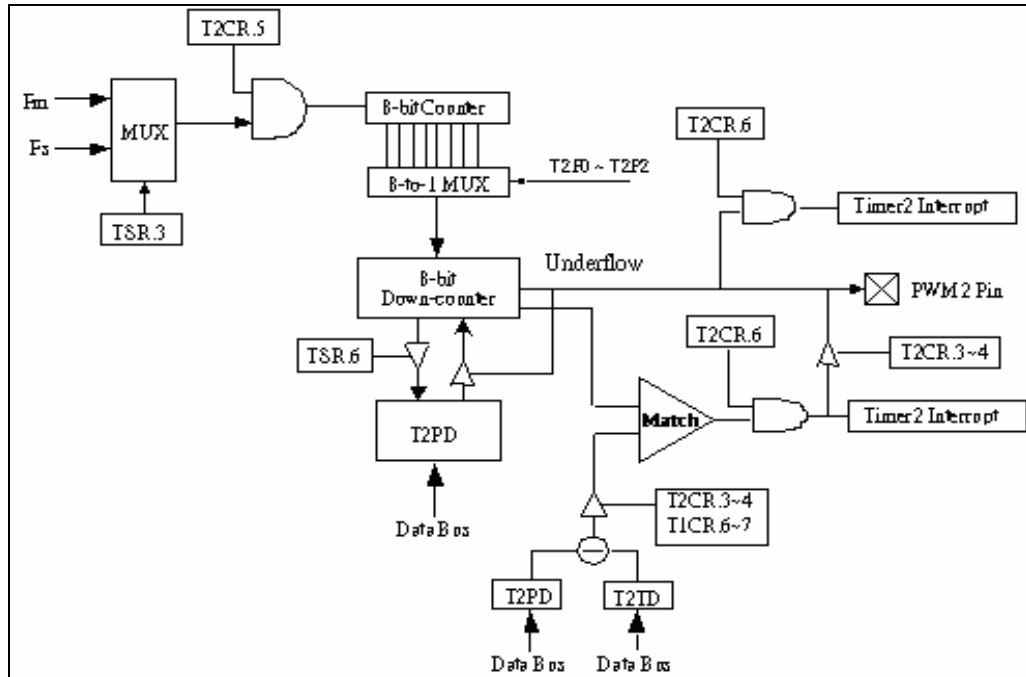

Fig 6-30 Timer 2 Configuration

### 6.14.1 Timer Mode

In Timer mode, counting down is performed using the internal clock with prescaler. When the counter value from T2PD underflows, interrupt is then generated and the counter is cleared. Counting down resumes after the counter is cleared. The counter value will automatically reload from T2PD.

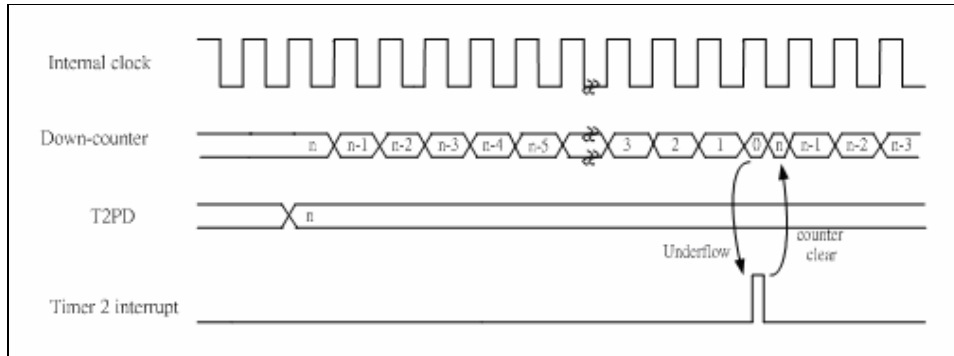

Fig 6-31 Timer Mode Timing Chart

### 6.14.2 PWM Mode

In Pulse Width Modulation (PWM) Output mode, counting down is performed using the internal clock with prescaler or  $F_{sub}$  with frequency. The PWM2 duty cycle is controlled by T2TD, and the PWM2 period is controlled by T2PD. The pulse at the PWM2 pin is held to high level as long as the T2TD counter value is greater than or equal to zero while the pulse is held to low level until the T2PD counter value underflows.

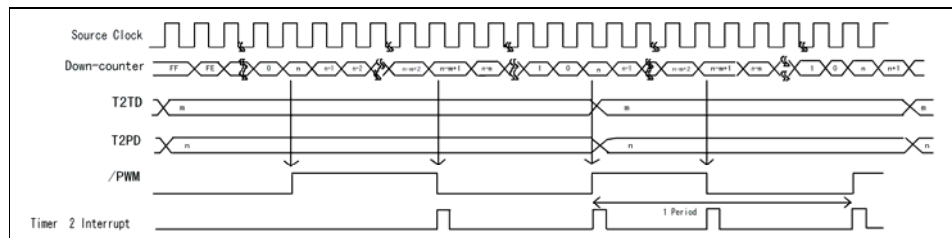

Fig 6-32 PWM Mode Timing Chart



## 6.15 Code Options

The EM78P510N has one Code Option word that is not part of the normal program memory. The option bits cannot be accessed during normal program execution.

Code Option Register and Customer ID Register arrangement distribution:

Word 0	Word1	Word 2
Bit 12~Bit 0	Bit 12~Bit 0	Bit 12~Bit 0

### 1. Code Option Register (Word 0)

Word 0												
Bit 12	Bit 11	Bit 10	Bit 9	Bit 8	Bit 7	Bit 6	Bit 5	Bit 4	Bit 3	Bit 2	Bit 1	Bit 0
TYPE1	TYPE0	LVREN	LVR1S	LVR0S	ENWDTB	FSMD	FMMD1	FMMD0	HLP	PR2	PR1	PR0

**Bits 12~11 (TYPE1~TYPE0):** Type Selection for 48 pins or 44 pins or 42 pins or 32 pins.

TYPE1	TYPE0	Type Selection
0	0	EM78P510 (32-pin SDIP/SOP)
0	1	EM78P510 (42-pin DIP)
1	0	EM78P510 (44-pin LQFP/QFP)
1	1	EM78P510 (48-pin LQFP) (default)

**Bit 10 (LVREN):** Low Voltage Reset Enable Bit

0 : Disable

1 : Enable

**Bits 9~8 (LVR1S~LVR0S):** Low Voltage Reset Voltage Select Bits

LVR1S	LVR0S	Reset Voltage
0	0	2.6V
0	1	3.3V
1	0	3.9V

**Bit 7 (ENWDTB):** Watchdog Timer Enable Bit

0 : Enable

1 : Disable

**Bits 6~4 (FSMD, FMMD1~FMMD0):** Oscillator Modes Selection Bits

FSMD	FMMD1	FMMD0	Main clock	Sub-clock
0	0	0	RC type (ERIC)	RC type (ERIC)
0	0	1	Crystal type	RC type (ERIC)
0	1	0	PLL type	RC type (ERIC)
0	1	1	PLL type	RC type (ERIC)
1	0	0	RC type (ERIC)	Crystal type
1	0	1	Crystal type	Crystal type
1	1	0	PLL type	Crystal type
1	1	1	Crystal	None



**Bit 3 (HLP):** Power Consumption Selection Bit

**0 :** Low power consumption, apply to working frequency at 4MHz or below 4MHz.

**1 :** High power consumption, apply to working frequency above 4MHz.

**Bits 2~0 (PR2~PR0):** Protect Bit

PR2~PR0 are protect bits, protect type are as follows:

PR2	PR1	PR0	Protect
0	0	0	Enable
1	1	1	Disable

## 2. Code Option Register (Word 1)

Word 1												
Bit 12	Bit 11	Bit 10	Bit 9	Bit 8	Bit 7	Bit 6	Bit 5	Bit 4	Bit 3	Bit 2	Bit 1	Bit 0
--	--	--	--	--	--	--	HLFS	--	--	FCB0	FCB1	RESETB

**Bits 12~6** (Not used)

**Bit 5 (HLFS):** Main or Sub Oscillator Select Bit

**0 :** CPU is selected as sub-oscillator when a reset occurs

**1 :** CPU is selected as main-oscillator when a reset occurs

**Bits 4~3** (Not used)

**Bits 2~1 (FCB1~FCB0):** Frequency Select Bit

FCB1	FCB0	Operation Frequency
0	0	100k~1M
0	1	1M~6M
1	0	6M~12M
1	1	12M~20M

**Bit 0 (RESETB):** Reset Pin Enable Bit

**0 :** Enable, P81//RESET → RESET pin

**1 :** Disable, P81//RESET → P81

## 3. Customer ID Register (Word 2)

Word 2												
Bit 12	Bit 11	Bit 10	Bit 9	Bit 8	Bit 7	Bit 6	Bit 5	Bit 4	Bit 3	Bit 2	Bit 1	Bit 0
Customer ID												

## 6.16 Instruction Set

Each instruction in the Instruction Set is a 13-bit word divided into an OP code and one or more operand. Normally, all instructions are executed within one single instruction cycle (one instruction consists of 2 oscillator periods), unless the program counter is changed by instruction "MOV R2,A", "ADD R2,A", or by instructions of arithmetic or logic operation on R2 (e.g. "SUB R2,A", "BS(C) R2,6", "CLR R2", ...). In this case, the execution takes two instruction cycles.

The following are executed within two instruction cycles; "LJMP", "LCALL", or conditional skip ("JBS", "JBC", "JZ", "JZA", "DJZ", "DJZA") instructions which were tested to be true. Instructions written to the program counter are also executed within two instruction cycles.

In addition, the instruction set has the following features:

- (1) Every bit of any register can be set, cleared, or tested directly.
- (2) The I/O register can be regarded as general register. That is, the same instruction can operate on the I/O register.

**Convention:**

**r** = Register designator that specifies which one of the registers (including operation and general purpose registers) is to be utilized by the instruction.

Bits 6 and 7 in R4 determine the selected register bank.

**b** = Bit field designator that selects the value for the bit located in the register R and which affects the operation.

**k** = 8 or 10-bit constant or literal value

Binary Instruction	Hex	Mnemonic	Operation	Status Affected
0 0000 0000 0000	0000	NOP	No Operation	None
0 0000 0000 0001	0001	DAA	Decimal Adjust A	C
0 0000 0000 0011	0003	SLEP	0 → WDT, Stop oscillator	T, P
0 0000 0000 0100	0004	WDTC	0 → WDT	T, P
0 0000 0001 0000	0010	ENI	Enable Interrupt	None
0 0000 0001 0001	0011	DISI	Disable Interrupt	None
0 0000 0001 0010	0012	RET	[Top of Stack] → PC	None



Binary Instruction	Hex	Mnemonic	Operation	Status Affected
0 0000 0001 0011	0013	RETI	[Top of Stack] → PC, Enable Interrupt	None
0 0000 01rr rrrr	00rr	MOV R,A	A → R	None
0 0000 1000 0000	0080	CLRA	0 → A	Z
0 0000 11rr rrrr	00rr	CLR R	0 → R	Z
0 0001 00rr rrrr	01rr	SUB A,R	R-A → A	Z, C, DC
0 0001 01rr rrrr	01rr	SUB R,A	R-A → R	Z, C, DC
0 0001 10rr rrrr	01rr	DECA R	R-1 → A	Z
0 0001 11rr rrrr	01rr	DEC R	R-1 → R	Z
0 0010 00rr rrrr	02rr	OR A,R	A ∨ R → A	Z
0 0010 01rr rrrr	02rr	OR R,A	A ∨ R → R	Z
0 0010 10rr rrrr	02rr	AND A,R	A & R → A	Z
0 0010 11rr rrrr	02rr	AND R,A	A & R → R	Z
0 0011 00rr rrrr	03rr	XOR A,R	A ⊕ R → A	Z
0 0011 01rr rrrr	03rr	XOR R,A	A ⊕ R → R	Z
0 0011 10rr rrrr	03rr	ADD A,R	A + R → A	Z, C, DC
0 0011 11rr rrrr	03rr	ADD R,A	A + R → R	Z, C, DC
0 0100 00rr rrrr	04rr	MOV A,R	R → A	Z
0 0100 01rr rrrr	04rr	MOV R,R	R → R	Z
0 0100 10rr rrrr	04rr	COMA R	/R → A	Z
0 0100 11rr rrrr	04rr	COM R	/R → R	Z
0 0101 00rr rrrr	05rr	INCA R	R+1 → A	Z
0 0101 01rr rrrr	05rr	INC R	R+1 → R	Z
0 0101 10rr rrrr	05rr	DJZA R	R-1 → A, skip if zero	None
0 0101 11rr rrrr	05rr	DJZ R	R-1 → R, skip if zero	None
0 0110 00rr rrrr	06rr	RRCA R	R(n) → A(n-1), R(0) → C, C → A(7)	C
0 0110 01rr rrrr	06rr	RRC R	R(n) → R(n-1), R(0) → C, C → R(7)	C
0 0110 10rr rrrr	06rr	RLCA R	R(n) → A(n+1), R(7) → C, C → A(0)	C
0 0110 11rr rrrr	06rr	RLC R	R(n) → R(n+1), R(7) → C, C → R(0)	C
0 0111 00rr rrrr	07rr	SWAPA R	R(0-3) → A(4-7), R(4-7) → A(0-3)	None
0 0111 01rr rrrr	07rr	SWAP R	R(0-3) ↔ R(4-7)	None
0 0111 10rr rrrr	07rr	JZA R	R+1 → A, skip if zero	None



Binary Instruction	Hex	Mnemonic	Operation	Status Affected
0 0111 11rr rrrr	07rr	JZ R	R+1 → R, skip if zero	None
0 100b brrr rrrr	0xxx	BC R,b	0 → R(b)	None
0 101b brrr rrrr	0xxx	BS R,b	1 → R(b)	None <sup>1</sup>
0 110b brrr rrrr	0xxx	JBC R,b	if R(b)=0, skip	None
0 111b brrr rrrr	0xxx	JBS R,b	if R(b)=1, skip	None
1 00kk kkkk kkkk	1kkk	CALL k	PC+1 → [Stack], (Page, k) → PC	None
1110 1010 kkkk k kkkk kkkk kkkk	1EAKkkk	LCALL k	PC+1 → [Stack], K → PC	None
1 01kk kkkk kkkk	1kkk	JMP k	(Page, k) → PC	None
1110 1011 kkkk k kkkk kkkk kkkk	1EBkkkk	LJMP k	K → PC	None
1 1000 kkkk kkkk	18kk	MOV A,k	k → A	None
1 1001 kkkk kkkk	19kk	OR A,k	A ∨ k → A	Z
1 1010 kkkk kkkk	1Akk	AND A,k	A & k → A	Z
1 1011 kkkk kkkk	1Bkk	XOR A,k	A ⊕ k → A	Z
1 1100 kkkk kkkk	1Ckk	RETL k	k → A, [Top of Stack] → PC	None
1 1101 kkkk kkkk	1Dkk	SUB A,k	k-A → A	Z, C, DC
1 1110 0kkk kkkk	1E0K	BANK k	k → R5(2:0)	None
1 1111 kkkk kkkk	1Fkk	ADD A,k	k+A → A	Z, C, DC

**Note:** <sup>1</sup> This instruction can't operate under interrupt status register.



## 7 Absolute Maximum Ratings

Items	Symbol	Condition	Rating		Unit
			Min.	Max.	
Supply voltage	V <sub>DD</sub>	–	2.3	5.5	V
Input voltage	V <sub>I</sub>	Port 7 ~ Port 9, Port A ~ Port C	GND-0.3	VDD+0.3	V
Output voltage	V <sub>O</sub>	Port 7 ~ Port 9, Port A ~ Port C	GND-0.3	VDD+0.3	V
Operation temperature	T <sub>OPR</sub>	–	-40	85	°C
Storage temperature	T <sub>STG</sub>	–	-65	150	°C
Power dissipation	P <sub>D</sub>	–	–	500	mW
Operating Frequency (2clk)	–	–	32.768K	16M	Hz

## 8 DC Electrical Characteristics

### 8.1 DC Electrical Characteristics

■ Ta= 25 °C, VDD= 5.0V±5%, VSS= 0V

Symbol	Parameter	Condition	Min.	Typ.	Max.	Unit
Fc	Crystal: VDD to 5V	Two cycle with two clocks	0.1		16	MHz
ERIC	ERIC: VDD to 5V	R: 51KΩ	F-20%	2.2221	F+20%	MHz
IIL	Input Leakage Current for input pins	VIN = VDD, VSS	-1	0	1	μA
VIH1	Input High Voltage (Schmitt Trigger)	Ports 7, 8, 9, A, B, C	0.75VDD	–	VDD+0.3V	V
VIL1	Input Low Voltage (Schmitt Trigger)	Ports 7, 8, 9, A, B, C	-0.3V	–	0.25VDD	V
VIHT1	Input High Threshold Voltage (Schmitt Trigger)	/RESET, INT	0.75VDD	–	VDD+0.3V	V
VILT1	Input Low Threshold Voltage (Schmitt Trigger)	/RESET, INT	-0.3V	–	0.25VDD	V
VIHX1	Clock Input High Voltage	OSCI in crystal mode	0.75VDD	–	VDD+0.3V	V
VILX1	Clock Input Low Voltage	OSCI in crystal mode	-0.3V	–	0.25VDD	V
IOH1	Output High Voltage (Port 9) LED enabled	VOH = VSS+2.1V	8	10	15	mA
IOH2	Output High Voltage (Ports 7, 8, 9, A, B, C)	VOH = VDD-0.5V	7	9	12	mA
IOL1	Output Low Voltage (Port 9) LED enabled	VOL = VDD-2.1	8	10	15	mA
IOL2	Output Low Voltage (Ports 7, 8, 9, A, B, C)	VOL = VSS+0.5V	16	18	21	mA
IPH1	Pull-high current	Pull-high active, input pin at VSS	-70	-75	-80	μA



Symbol	Parameter	Condition	Min.	Typ.	Max.	Unit	
ISB1	Stop mode Power down current	All input and I/O pins at VDD, Output pin floating	WDT disabled	–	1.1	–	μA
ISB2	Stop mode Power down current		WDT enabled	–	6.6	–	μA
ICC1	Idle mode current	/RESET= 'High', CPU OFF, Sub-oscillator clock (32.768kHz) ON, Output pin floating, WDT disabled	–	4.7	–	μA	
ICC2	Idle mode current	/RESET= 'High', CPU OFF, Sub-oscillator clock (32.768kHz) ON, Output pin floating, WDT enabled,	–	10.3	–	μA	
ICC3	Idle mode current	/RESET= 'High', CPU OFF, Sub-oscillator clock (32.768kHz) ON, Output pin floating, WDT disabled, LCD enabled	–	23.7	–	μA	
ICC4	Green mode current	/RESET= 'High', CPU ON, used Sub-oscillator clock (32.768kHz), Output pin floating, WDT enabled,	–	21.4	–	μA	
ICC5	Normal mode	/RESET= 'High', Fosc=4MHz (Crystal type, CLKS="0"), Output pin floating, WDT enabled	–	1.48	–	mA	
ICC6	Normal mode	/RESET= 'High', Fosc=16MHz (Crystal type, CLKS="0"), Output pin floating, WDT enabled	–	3.45	–	mA	
RLCD	LCD Voltage Dividing Resistor	Ta = 25 °C	–	80	–	KΩ	
ILCD1	All LCD lighting	VLCD=5V, exclude CPU core operation current (not panel)	–	23.3	–	μA	
ILCD2	All LCD lighting	VLCD=3V, exclude CPU core operation current (not panel)	–	12.9	–	μA	

\* Typical values are based on characterization results at 25 °C



## 8.2 A/D Converter Characteristic

■ VDD=2.5V to 5.5V, VSS=0V, Ta=-40 to 85 °C

Symbol	Parameter	Condition	Min	Typ	Max	Unit
VREF	Analog reference voltage	VREF - VSS ≥ 2.5V	2.5	–	VDD	V
VSS			VSS	–	VSS	V
VAI	Analog input voltage	–	VSS	–	VREF	V
IAI1	Analog supply current	VDD=VREF=5.0V, VSS = 0.0V (V reference from VDD)	750	850	1000	μA
			-10	0	+10	μA
IAI2	Analog supply current	VDD=VREF=5.0V, VSS = 0.0V (V reference from VREF)	500	600	820	μA
			200	250	300	μA
RN1	Resolution	ADREF=0, Internal VDD VDD=5.0V, VSS = 0.0V	–	9	10	Bits
RN2	Resolution	ADREF=1, External VREF VDD=VREF=5.0V, VSS = 0.0V	–	11	12	Bits
LN1	Linearity error	VDD= 2.5 to 5.5V Ta=25°C	0	±4	±8	LSB
LN2	Linearity error	VDD= 2.5 to 5.5V Ta=25°C	0	±2	±4	LSB
DNL	Differential non-linear error	VDD= 2.5 to 5.5V Ta=25°C	0	±0.5	±0.9	LSB
FSE1	Full scale error	VDD=5.0V, VASS = 0.0V	±0	±4	±8	LSB
FSE2	Full scale error	VDD=VREF=5.0V, VSS = 0.0V	±0	±2	±4	LSB
OE	Offset error	VDD=VREF=5.0V, VSS = 0.0V	±0	±2	±4	LSB
ZAI	Recommended impedance of analog voltage source	–	0	8	10	KΩ
ADIV	A/D input voltage range	VDD =VREF=5.0V, VSS = 0.0V	0	–	VREF	V
ADOV	A/D output voltage swing	VDD =VREF=5.0V, VSS = 0.0V, RL=10KΩ	0	0.2	0.3	V
			4.7	4.8	5	
TAD	A/D clock period	VDD=VREF=5.0V, VSS = 0.0V	4	–	–	μs
TCN	A/D conversion time	VDD=VREF=5.0V, VSS = 0.0V	15	–	15	TAD
PSR	Power Supply Rejection	VDD=5.0V±0.5V	±0	–	±2	LSB



## 8.3 Phase Lock Loop Characteristic

### 8.3.1 PLL DC Electrical Characteristic

Symbol	Parameter	Condition	Min	Typ	Max	Unit
VD	Digital Supply Voltage	–	2.3	–	5.5	V

### 8.3.2 AC Electrical Characteristic

Parameter	Condition			Min	Typ	Max	Unit
Input Clock	–			–	32.768	–	kHz
Output Clock	CLK2	CLK1	CLK0	–	–	–	–
	0	0	0	–	3.997	–	MHz
	0	0	1	–	1.998	–	MHz
	0	1	0	–	0.999	–	MHz
	0	1	1	–	499.7	–	KHz
	1	0	0	–	7.995	–	MHz
	1	0	1	–	11.99	–	MHz
	1	1	X	–	15.99	–	MHz
Current Consumption	Normal			–	–	500	μA
	Power Down Mode			–	–	1	μA
Lock Up Time	–			–	–	200	μs
Frequency Accuracy	–			-30	–	+30	ppm

## 8.4 Device Characteristic

The graphs provided in the following pages were derived based on a limited number of samples and are shown here for reference only. The device characteristic illustrated herein are not guaranteed for its accuracy. In some graphs, the data may be out of the specified warranted operating range.

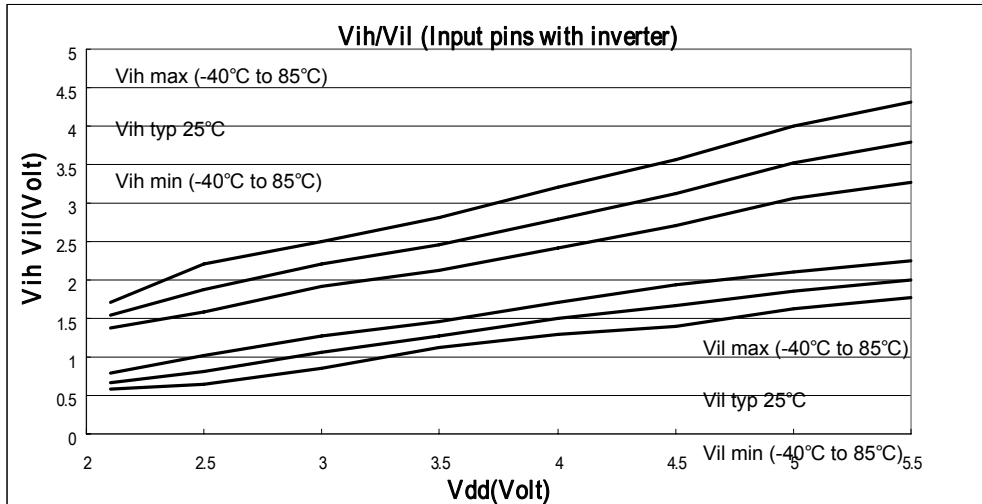

Fig. 8-1 Vih, Vil vs. VDD

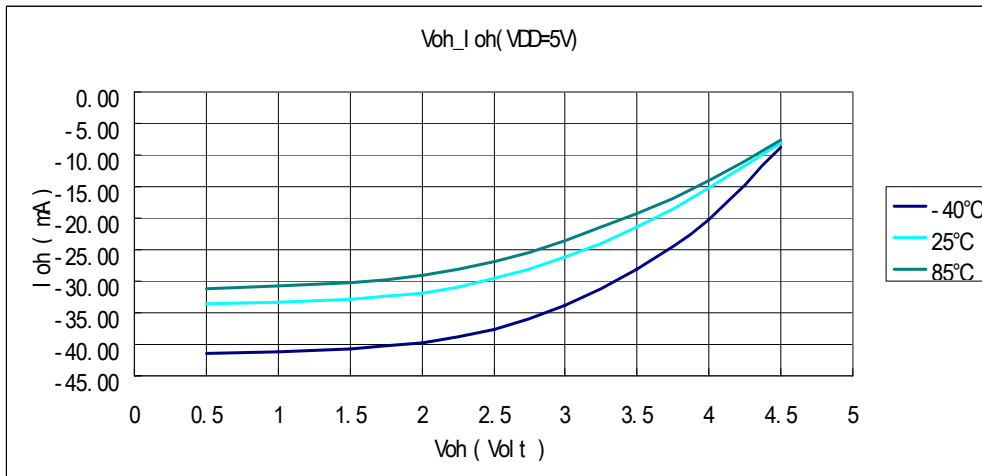

Fig. 8-2 Voh vs. Ioh, VDD=5V

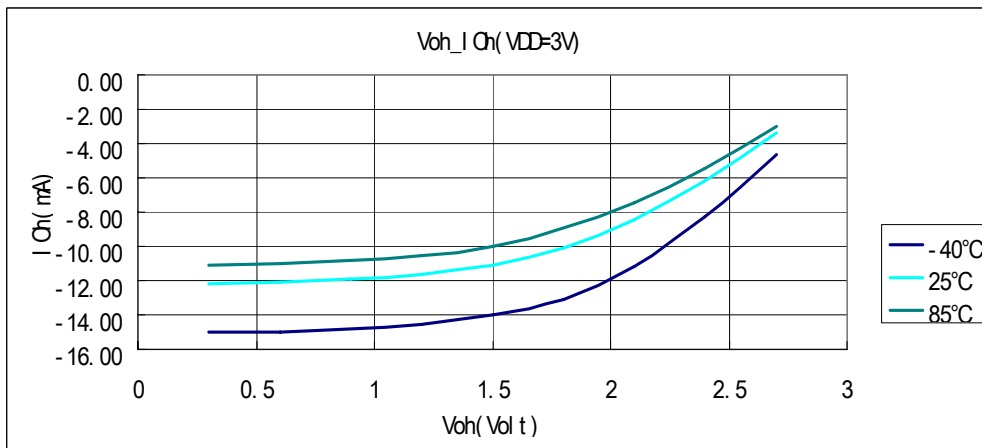

Fig. 8-3 Voh vs. Ioh, VDD=3V

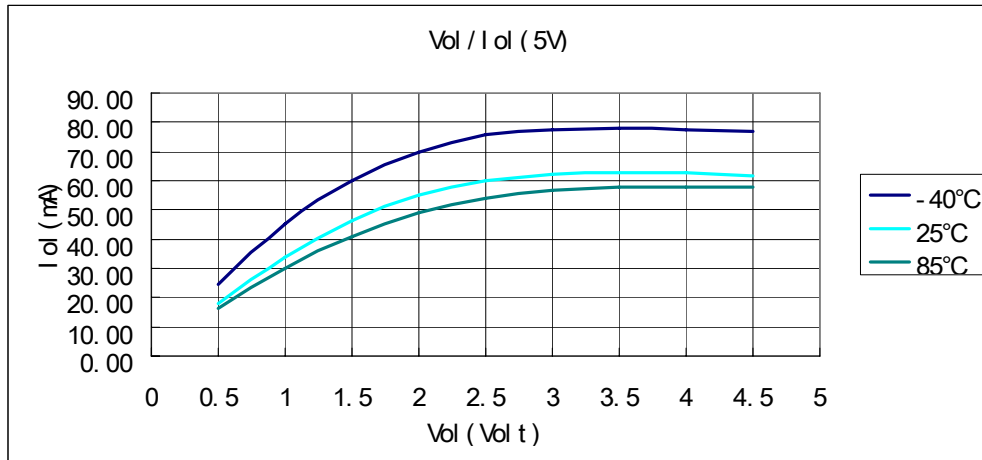

Fig. 8-4 Vol vs. Iol, VDD=5V

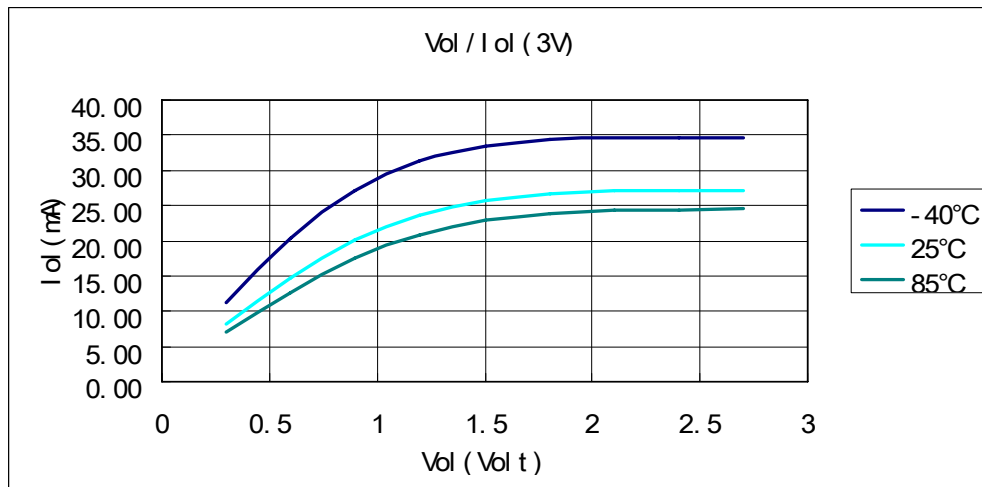

Fig. 8-5 Vol vs. Iol, VDD=3V

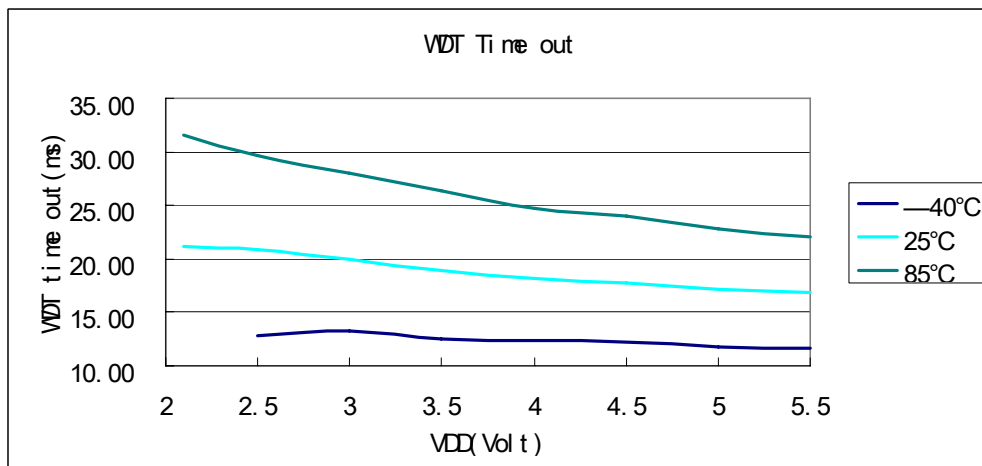

Fig. 8-6 WDT time out period vs. VDD, perscaler set to 1:1

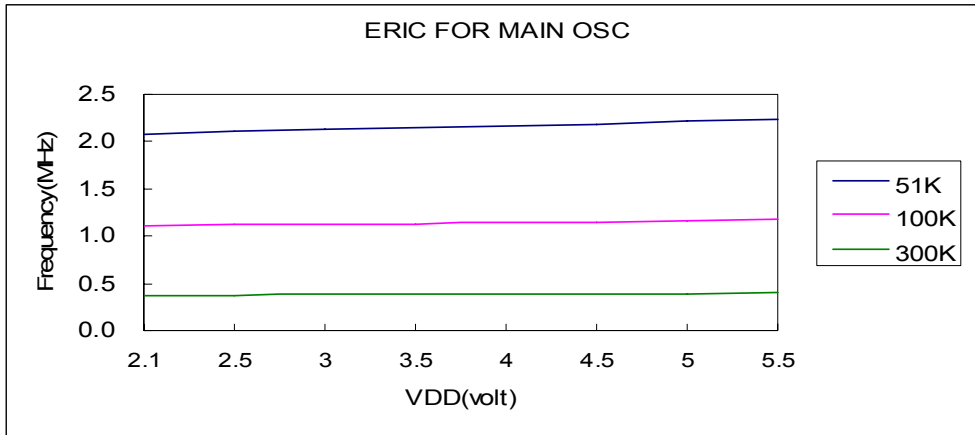

Fig. 8-7 ERIC fosc vs. VDD

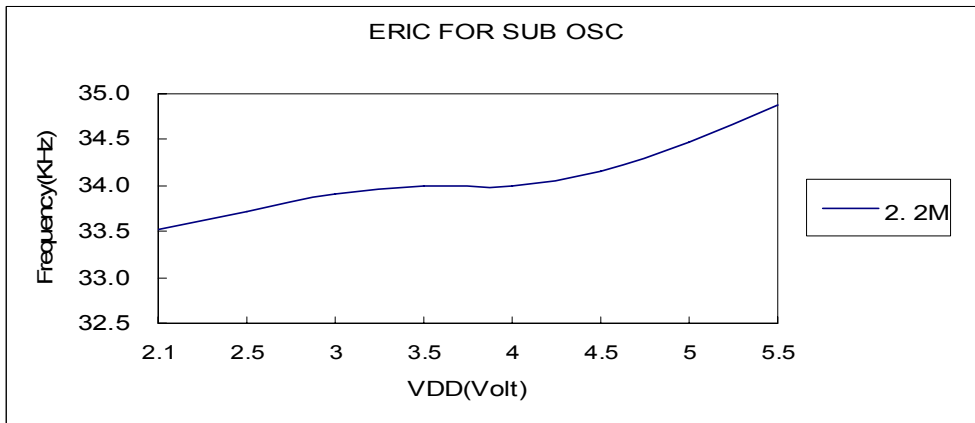

Fig. 8-8 ERIC fs vs. VDD

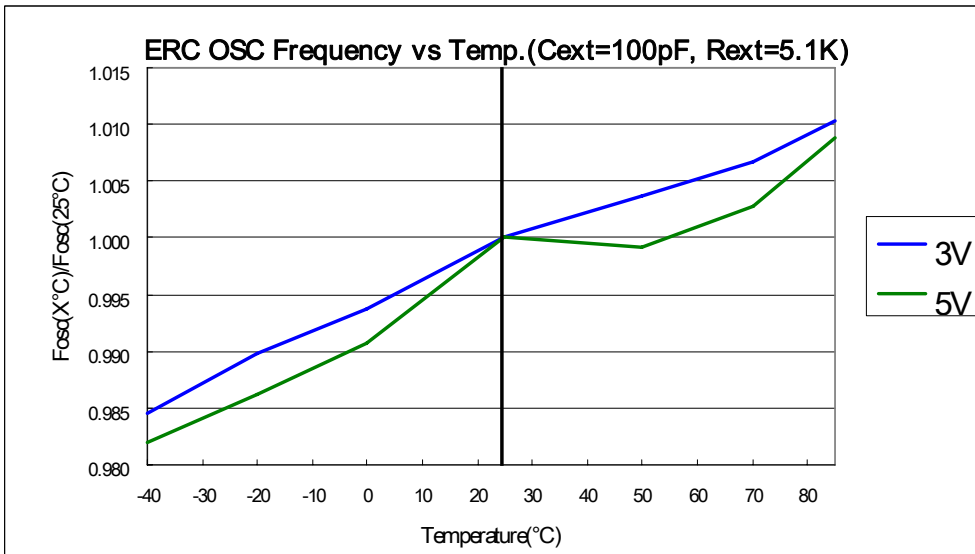

Fig. 8-9 ERIC fosc vs. Temperature

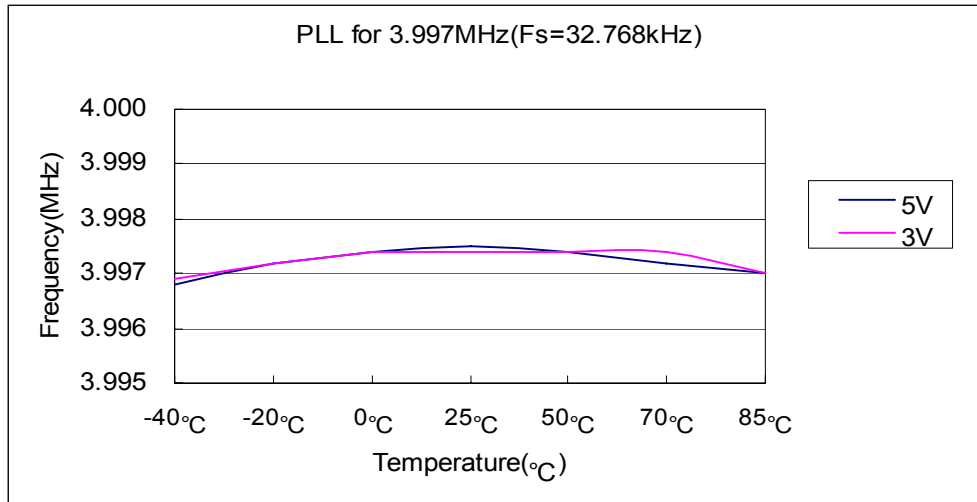

Fig. 8-10 PLL vs. Temperature

There are two conditions with the Standby Current ISB1 and ISB2. These conditions are as follows:

ISB1: WDT disable (Sleep mode)

ISB2: WDT enable (Sleep mode)

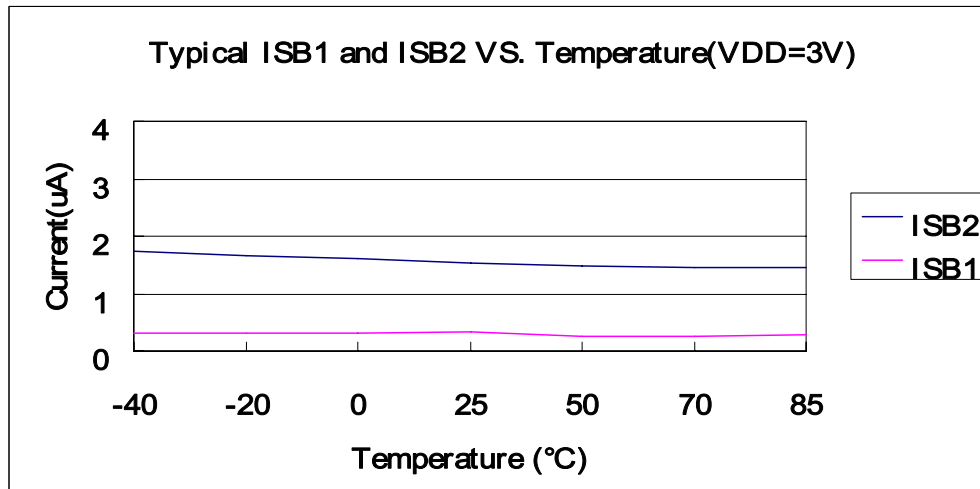

Fig. 8-11 Typical standby current (VDD=3V) vs. Temperature

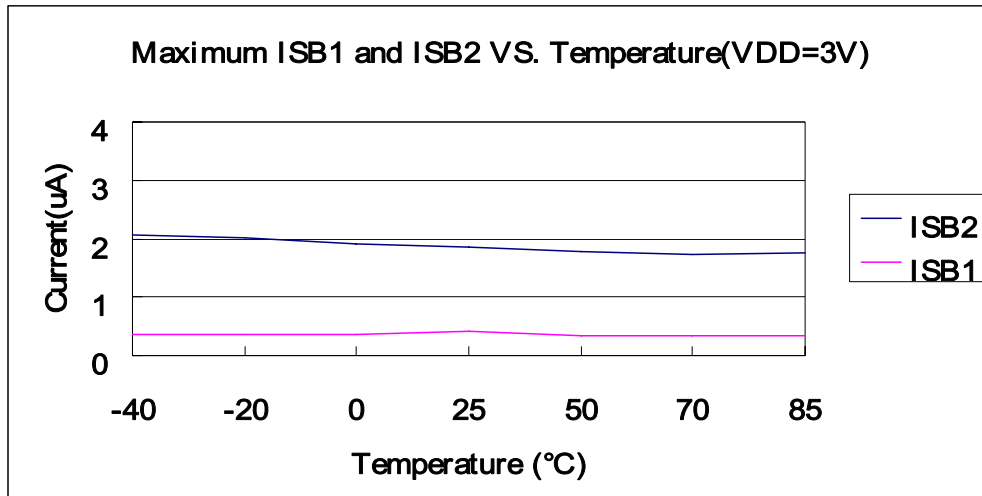

Fig. 8-12 Maximum standby current (VDD=3V) vs. Temperature

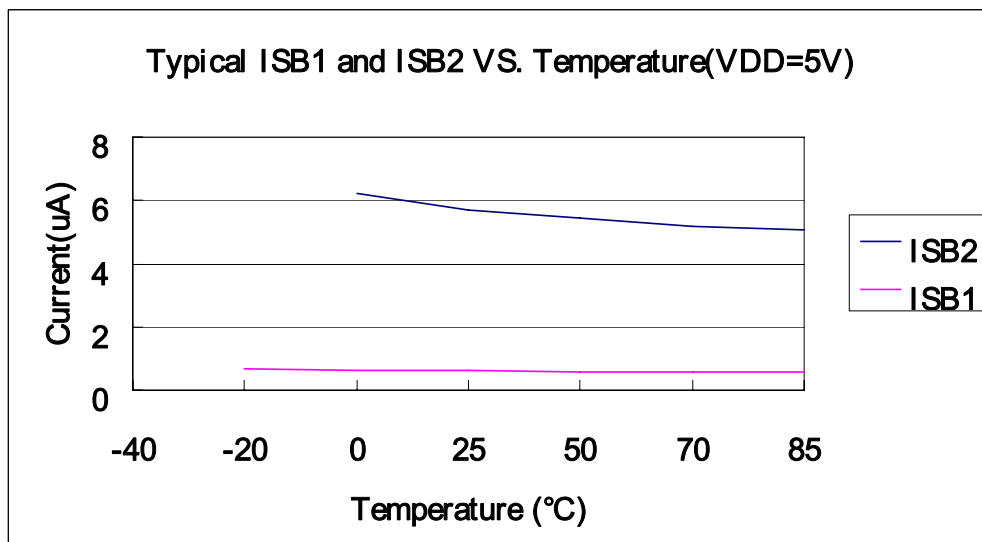

Fig. 8-13 Typical standby current (VDD=5V) vs. Temperature

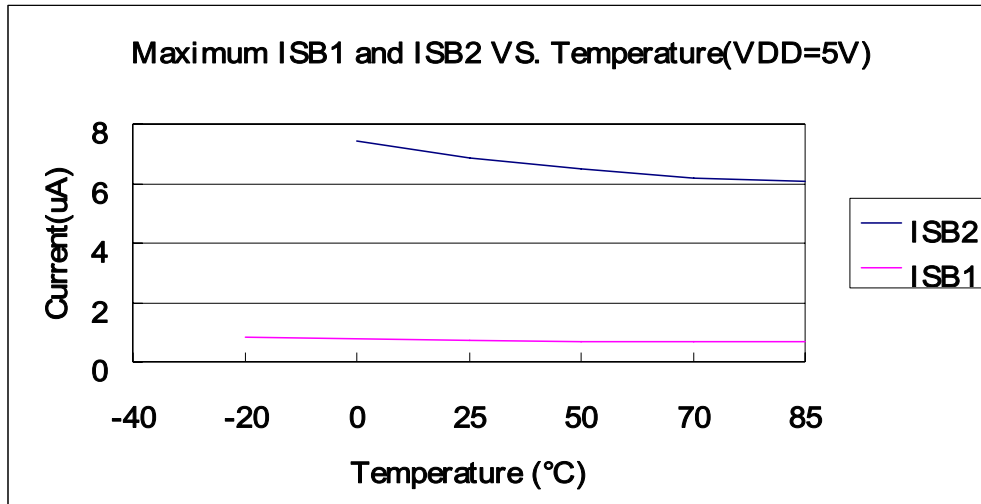

Fig. 8-14 Maximum standby current (VDD=5V) vs. Temperature

Four conditions exist with the Operating Current ICC1 to ICC6. These conditions are as follows:

ICC1: Fosc=32.768kHz, 2 clocks, WDT disable (Idle mode)

ICC2: Fosc=32.768kHz, 2 clocks, WDT enable (Idle mode)

ICC4: Fosc=32.768kHz, 2 clocks, WDT enable (Green mode)

ICC5: Fosc=4MHz, 2 clocks, WDT enable (Normal mode)

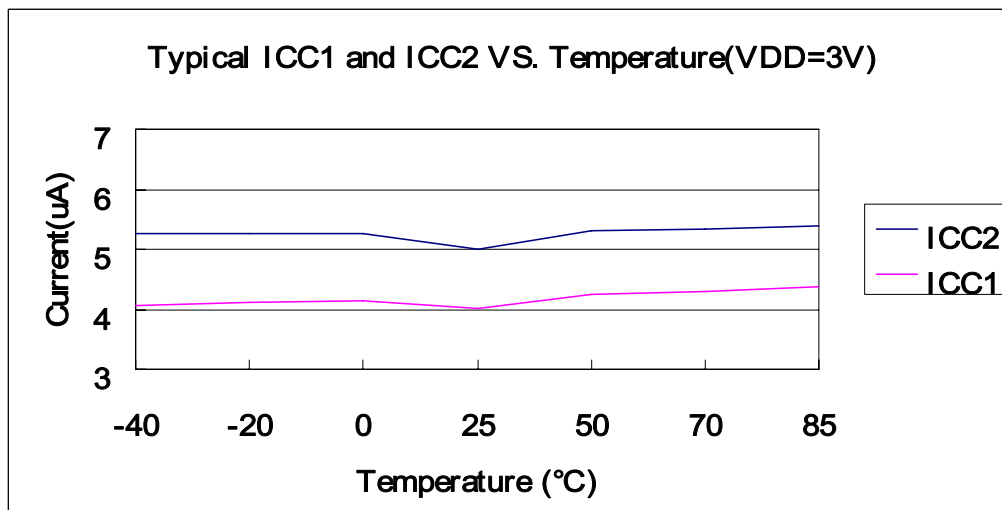

Fig. 8-15 Typical operating current (VDD=3V) vs. Temperature

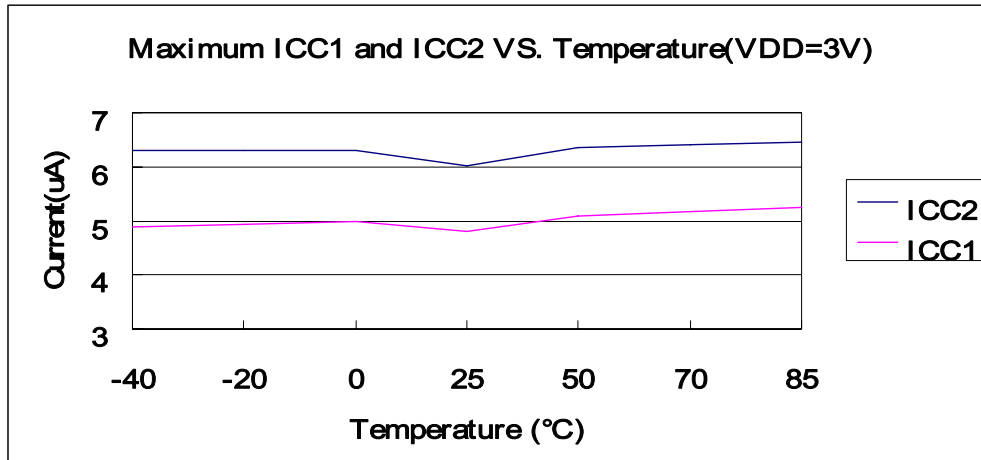

Fig. 8-16 Maximum operating current (VDD=3V) vs. Temperature

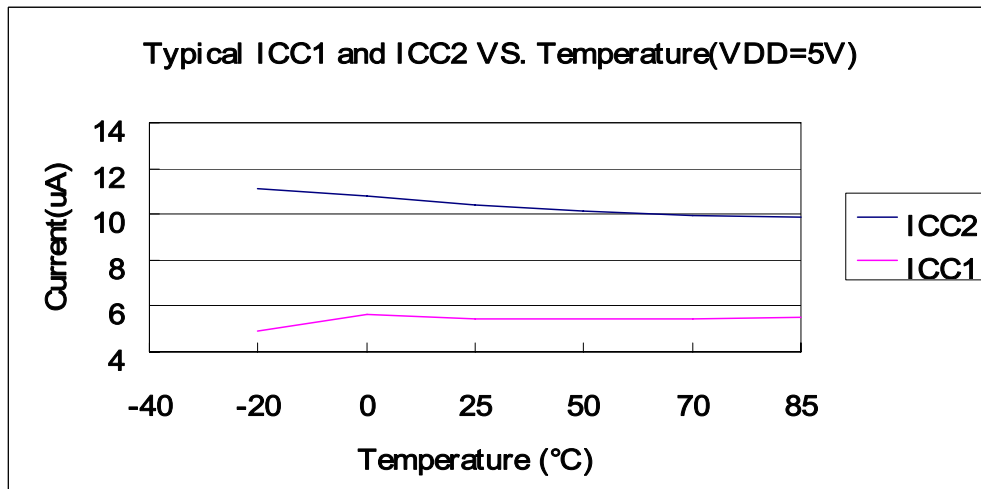

Fig. 8-17 Typical operating current (VDD=5V) vs. Temperature

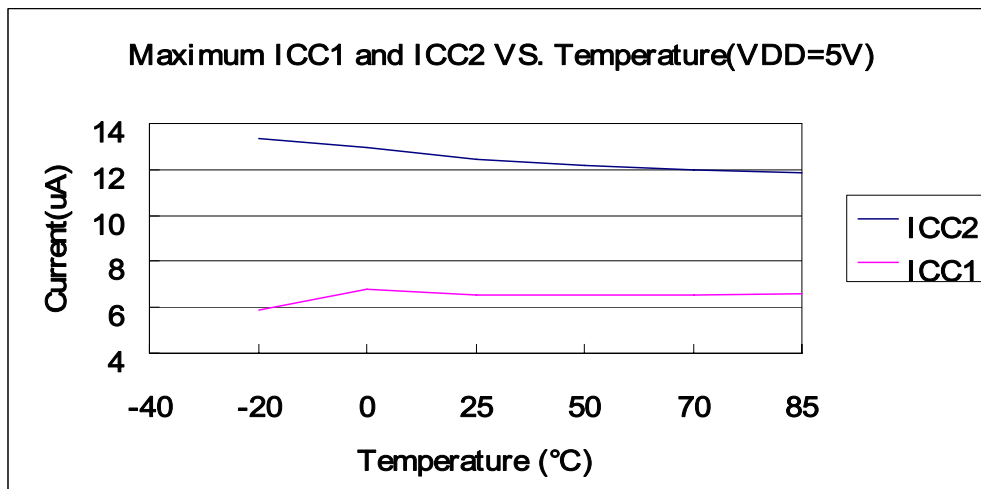

Fig. 8-18 Maximum operating current (VDD=5V) vs. Temperature

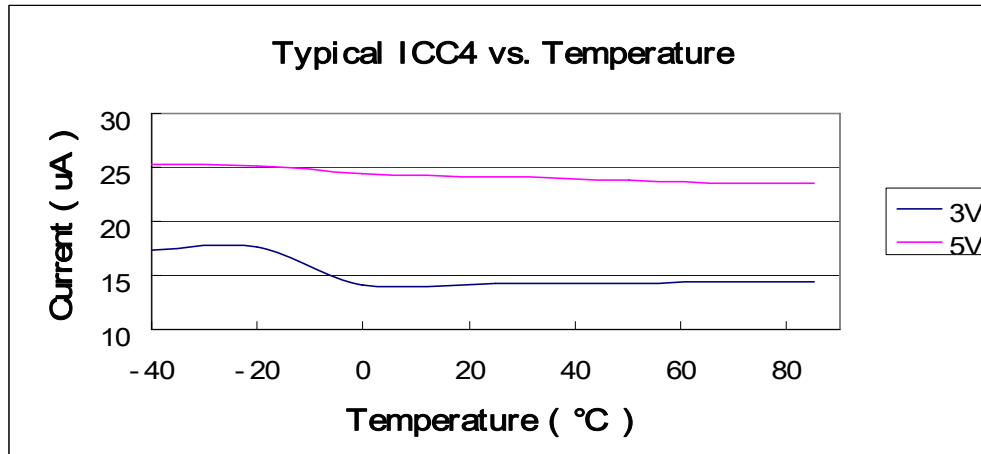

Fig. 8-19 Typical operating current vs. Temperature

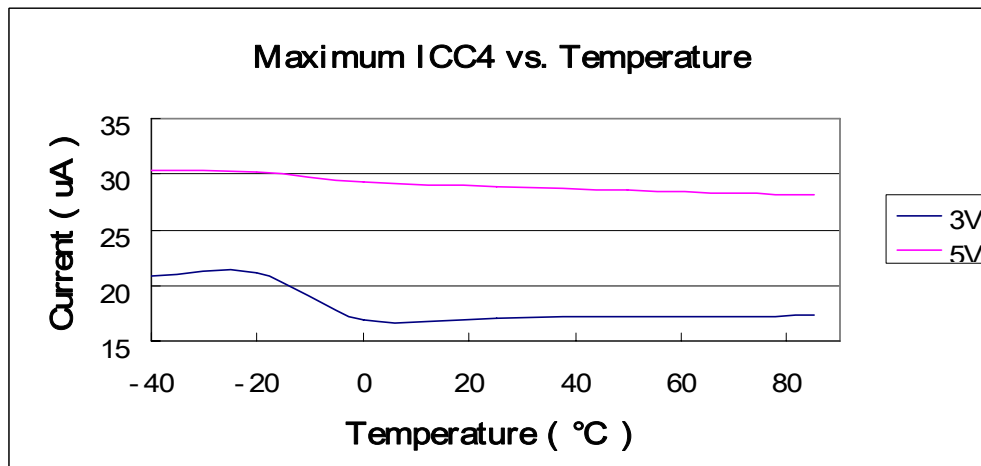

Fig. 8-20 Maximum operating current vs. Temperature

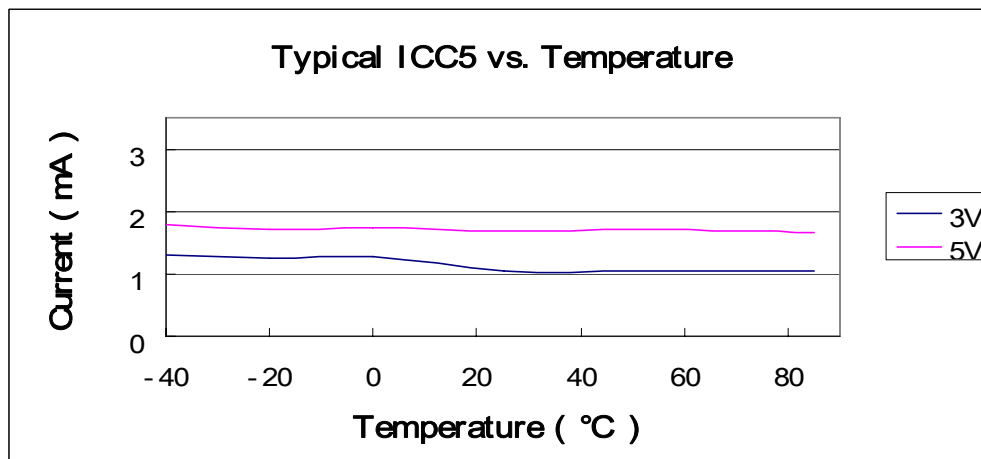

Fig. 8-21 Typical operating current vs. Temperature

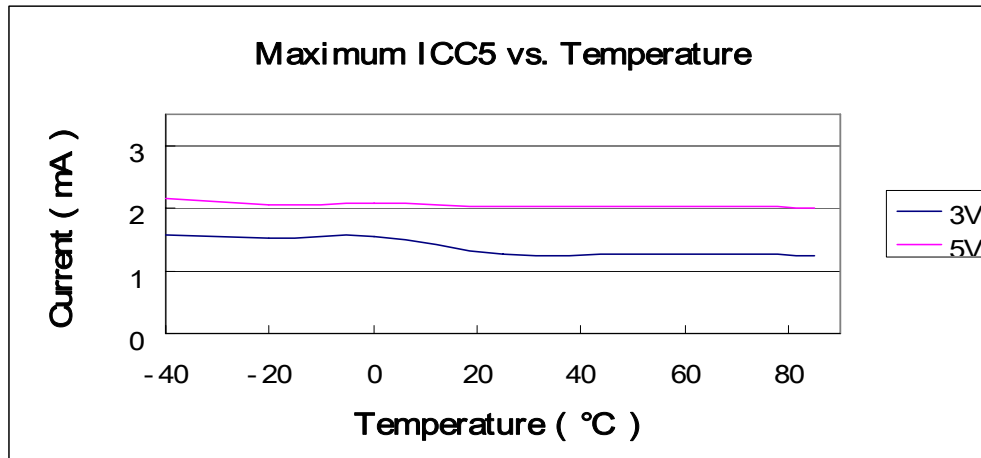

Fig. 8-22 Maximum operating current vs. Temperature



## 9 AC Electrical Characteristics

■ (Ta= -40 °C ~ 85 °C, VDD=5V±5%, GND=0V)

Symbol	Parameter	Conditions	Min	Typ	Max	Unit
Dclk	Input CLK duty cycle	–	45	50	55	%
Tins	Instruction cycle time (CLKS="0")	Crystal type	100	–	DC	ns
		RC type	500	–	DC	ns
Tdrh	Device reset hold time	Ta = 25 °C	11.3	16.2	21.6	ms
Trst	/RESET pulse width	Ta = 25 °C	2000	–	–	ns
Twdt	Watchdog timer period	Ta = 25 °C	11.3	16.2	21.6	ms
Tset	Input pin setup time	–	–	0	–	ns
Thold	Input pin hold time	–	–	20	–	ns
Tdelay	Output pin delay time	Clload=20pF	–	50	–	ns
Tiod	I/O delay for EMI enable	Clload=150pF	4	5	6	ns

## 10 Timing Diagrams

AC Test Input/Output Waveform

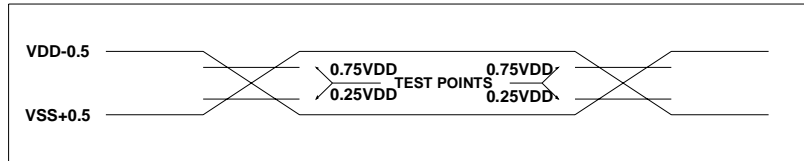

AC Testing : Input is driven at VDD-0.5V for logic "1", and VSS+0.5V for logic "0". Timing measurements are made at 0.75VDD for logic "1", and 0.25VDD for logic "0".

RESET Timing (CLK="0")

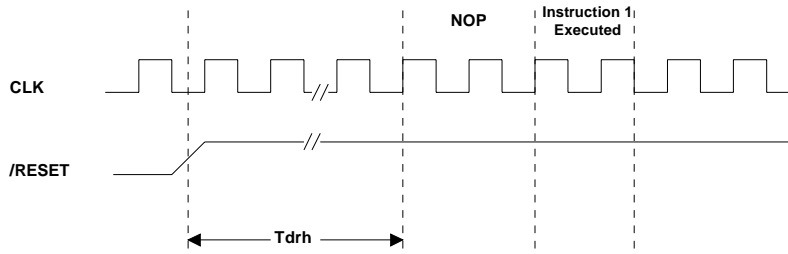

TCC Input Timing (CLKS="0")

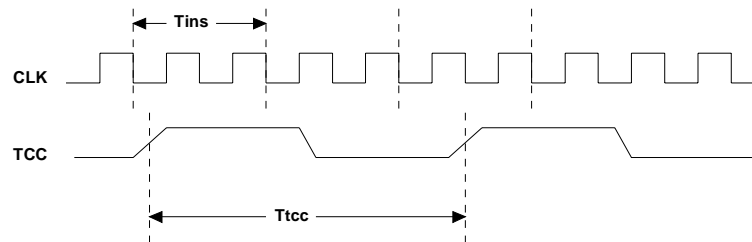

\* n = 0, 2, 4, 6

## APPENDIX

### A Package Type

OTP MCU	Package Type	Pin Count	Package Size
EM78P510NQS/J	LQFP	48	7 mm x 7 mm
EM78P510NAQS/J	LQFP	44	10 mm x 10 mm
EM78P510NBQS/J	QFP	44	10 mm x 10 mm
EM78P510NPS/J	DIP	42	600 mil
EM78P510NK/AKS/J	SDIP	32	400 mil
EM78P510NM/AMS/J	SOP	32	450 mil

S/J: Green product is not contain hazardous substances

The third edition of Sony SS-00259 standard.

Pb content should be less the 100ppm

Pb content to fit in with Sony spec.

Part no.	EM78P153xS/xJ
Electroplate type	Pure Tin
Ingredient (%)	Sn:100%
Melting point(°C)	232°C
Electrical resistivity ( $\mu$ uohm-cm)	11.4
Hardness (hv)	8~10
Elongation (%)	>50%

## B Package Information

### B.1 48-Lead Low Profile Quad Flat Package (LQFP)

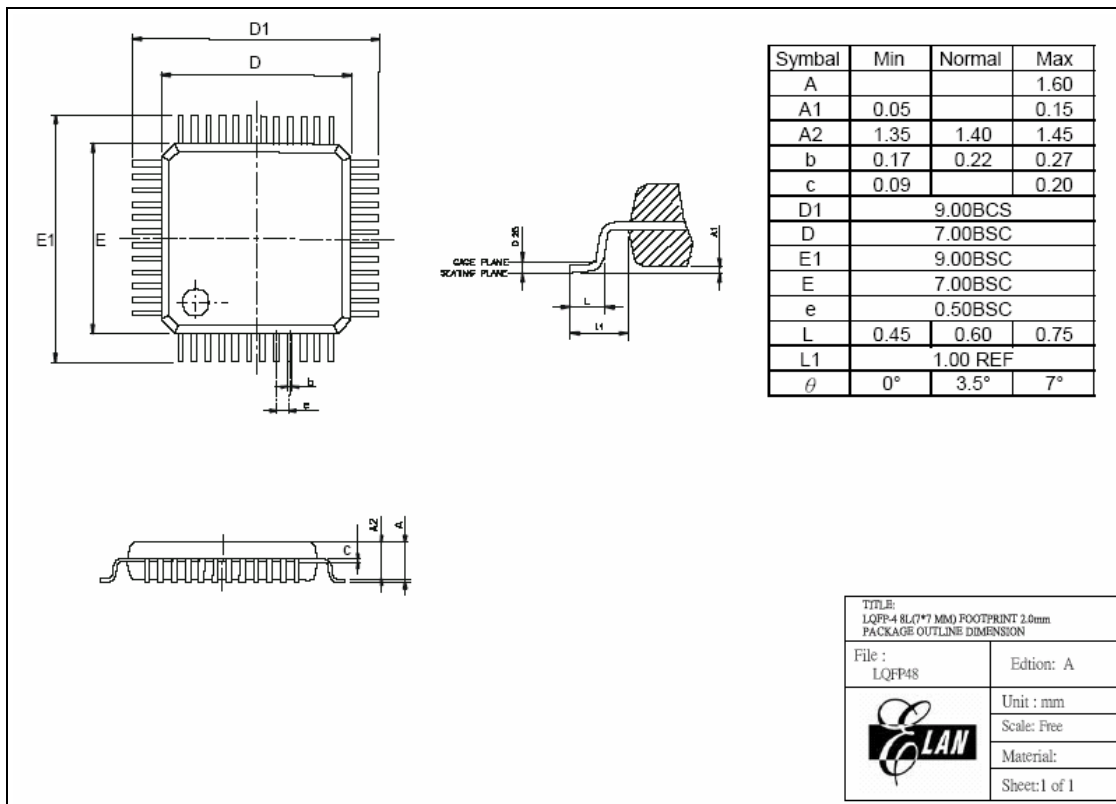

## B.2 44-Lead Low Profile Quad Flat Package (LQFP)

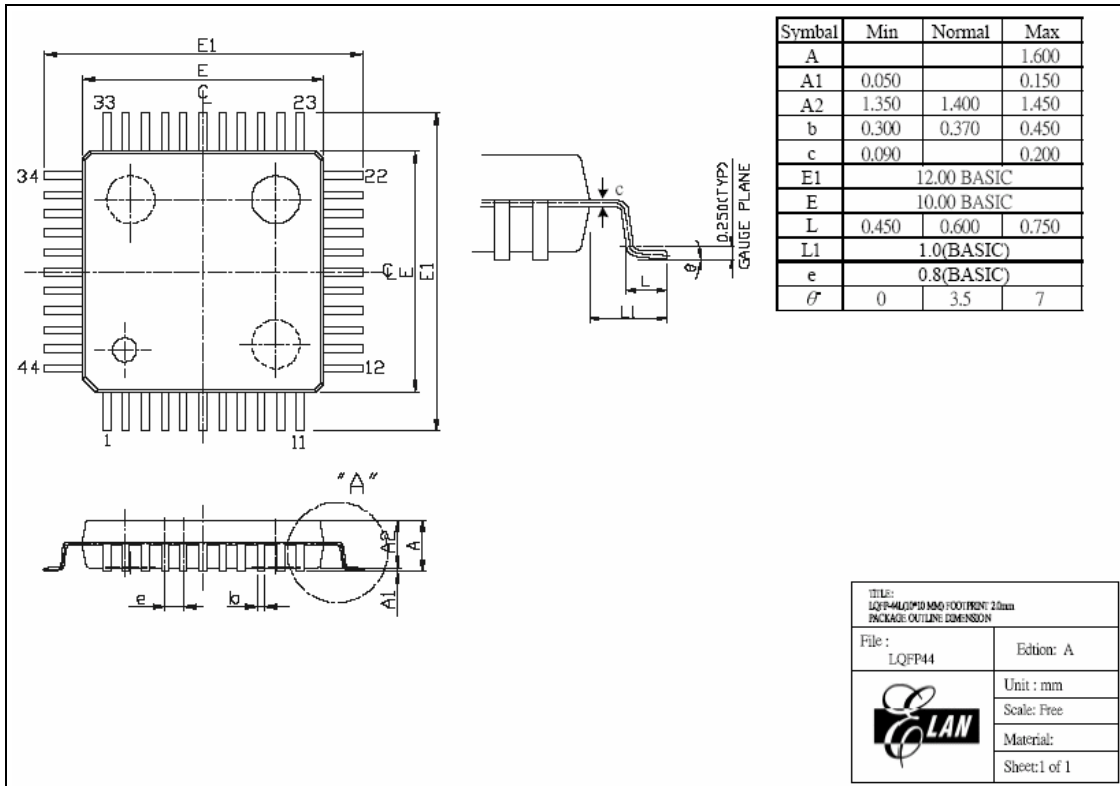

### B.3 44-Lead Quad Flat Package (QFP)

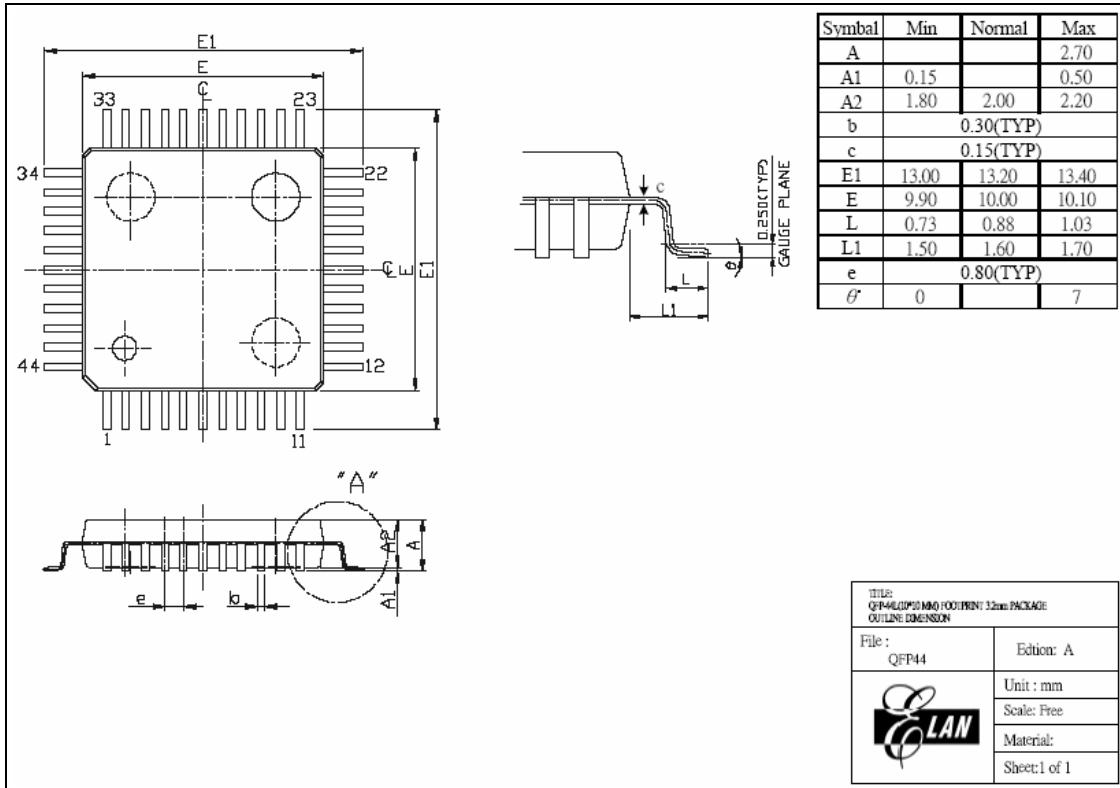

### B.4 42-Lead Dual Inline Package (DIP)

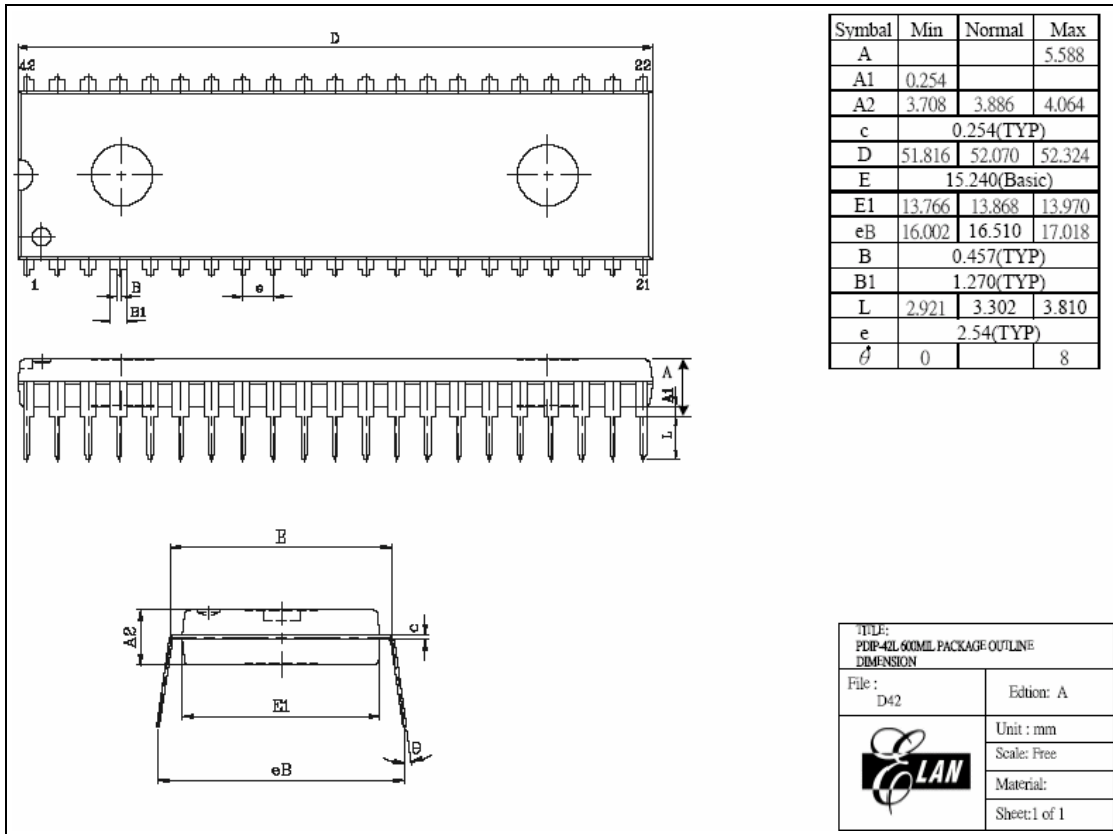

## B.5 32-Lead Shrink Dual Inline Package (SDIP)

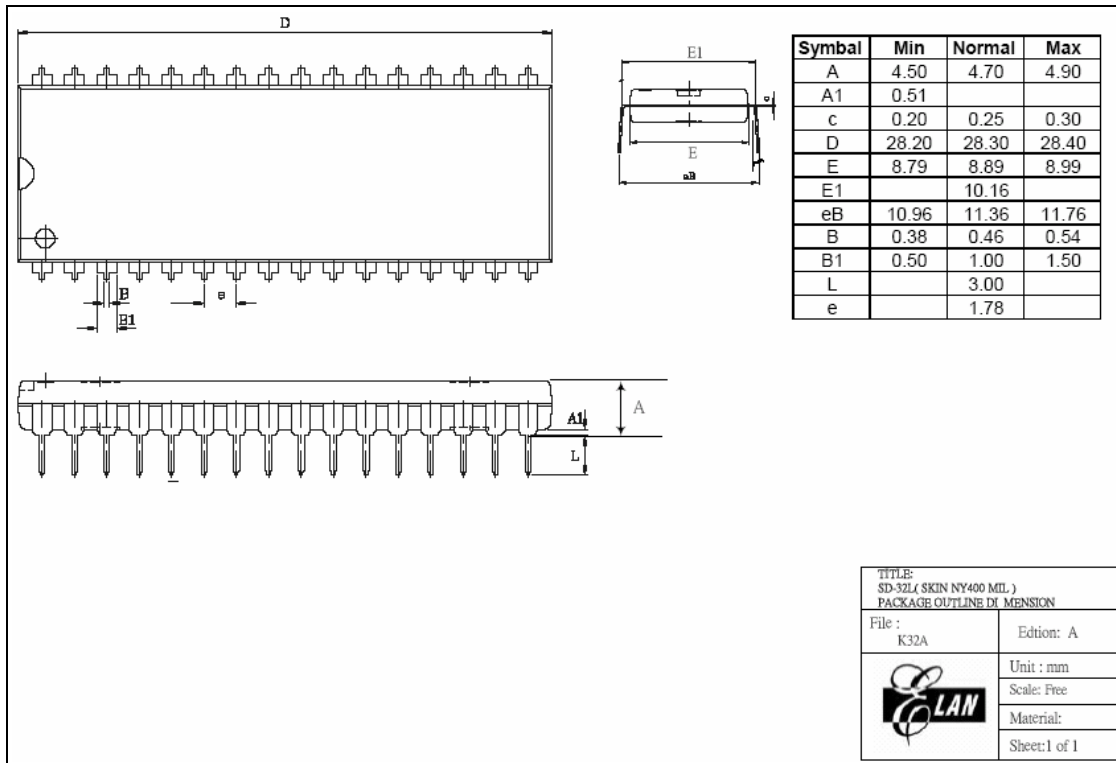

### B.6 32-Lead Small Outline Package (SOP)

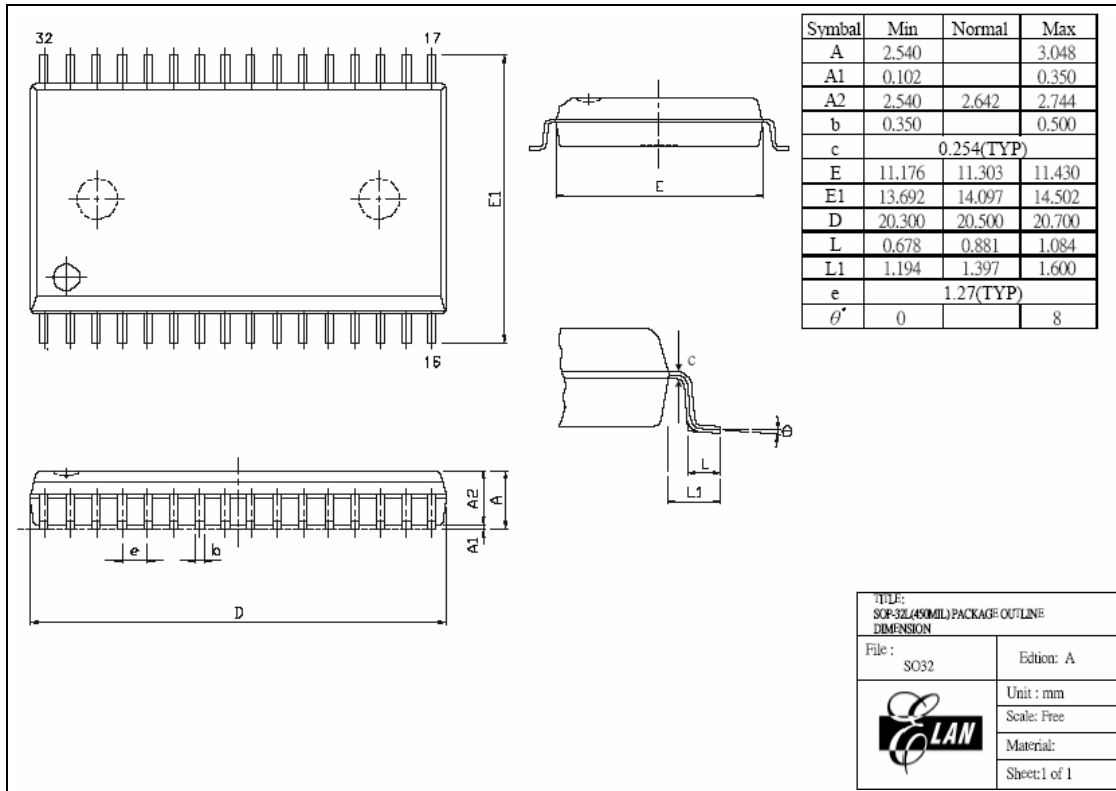



## C Quality Assurance and Reliability

Test Category	Test Conditions	Remarks
Solderability	Solder temperature=245±5°C, for 5 seconds up to the stopper using a rosin-type flux	
Pre-condition	Step 1: TCT, 65°C (15mins)~150°C (15mins), 10 cycles	For SMD IC (such as SOP, QFP, SOJ, etc)
	Step 2: Bake at 125°C, TD (endurance)=24 hrs	
	Step 3: Soak at 30°C/60% , TD (endurance)=192 hrs	
	Step 4: IR flow 3 cycles (Pkg thickness ≥ 2.5mm or Pkg volume ≥ 350mm <sup>3</sup> ----225±5°C) (Pkg thickness ≤ 2.5mm or Pkg volume ≤ 350mm <sup>3</sup> ----240±5°C )	
Temperature cycle test	-65°C (15mins)~150°C (15mins), 200 cycles	
Pressure cooker test	TA =121°C, RH=100%, pressure=2 atm, TD (endurance)= 96 hrs	
High temperature / High humidity test	TA=85°C , RH=85% , TD (endurance)=168 , 500 hrs	
High-temperature storage life	TA=150°C, TD (endurance)=500, 1000 hrs	
High-temperature operating life	TA=125°C, VCC=Max. operating voltage, TD (endurance) =168, 500, 1000 hrs	
Latch-up	TA=25°C, VCC=Max. operating voltage, 150mA/20V	
ESD (HBM)	TA=25°C, ≥ ± 3KV	IP_ND,OP_ND,IO_ND IP_NS,OP_NS,IO_NS IP_PD,OP_PD,IO_PD, IP_PS,OP_PS,IO_PS, VDD-VSS(+),VDD_VSS (-)mode
ESD (MM)	TA=25°C, ≥ ± 300V	

### C.1 Address Trap Detect

An address trap detect is one of the MCU embedded fail-safe functions that detects MCU malfunction caused by noise or the like. Whenever the MCU attempts to fetch an instruction from a certain section of ROM, an internal recovery circuit is auto started. If a noise caused address error is detected, the MCU will repeat execution of the program until the noise is eliminated. The MCU will then continue to execute the next program.

## D EM78P510N Program Pin List

DWTR is used to program the EM78P510N IC's. The connector of DWTR is selected by CON3 (EM78P447). The software is selected by EM78P510.

Program Pin Name	IC Pin Name	LQFP-48 Pin Number	L/QFP-44 Pin Number	DIP-42 Pin Number	SDIP/SOP-32 Pin Number
Pin #31	P75	2	2	8	29
Pin #30	P76	3	3	9	30
Pin #28	P77	4	4	10	31
Pin #8	VDD	5	5	11	32
Pin #10	VSS	6	6	12	1
Pin #34	TEST	9	9	15	4
Pin #29	PC2	10	10	16	5
Pin #32	PC3	11	11	17	6

## E ICE 510 Oscillator circuit (JP4)

### E.1 Mode 1

Main oscillator: Crystal mode, Sub oscillator: Crystal mode

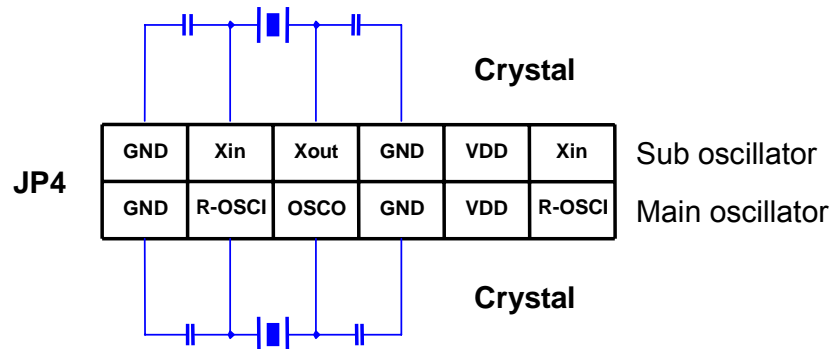

## E.2 Mode2

Main oscillator: PLL mode, Sub oscillator: Crystal mode

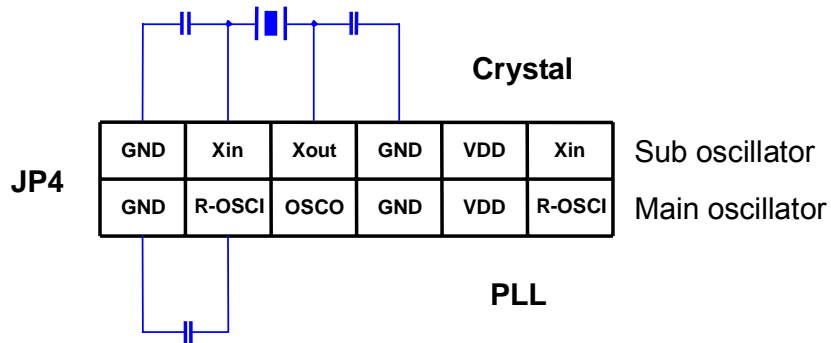

## E.3 Mode3

Main oscillator: ERIC mode, Sub oscillator: Crystal mode

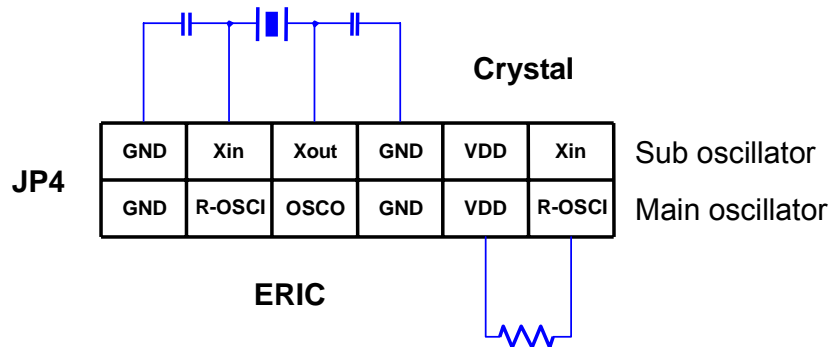

## E.4 Mode4

Main oscillator: Crystal mode, Sub oscillator: ERIC mode

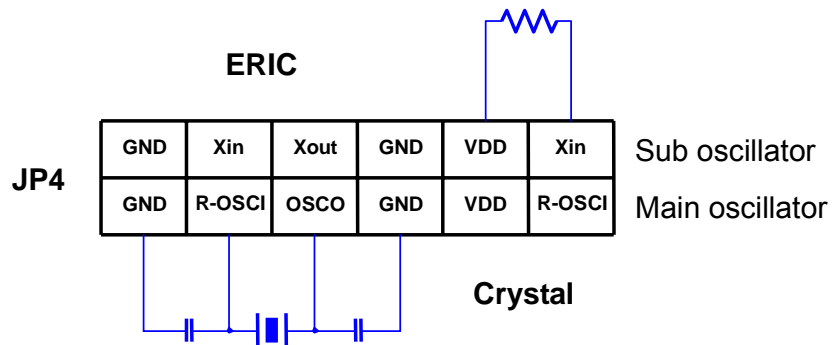

### E.5 Mode5

Main oscillator: PLL mode, Sub oscillator: RC mode

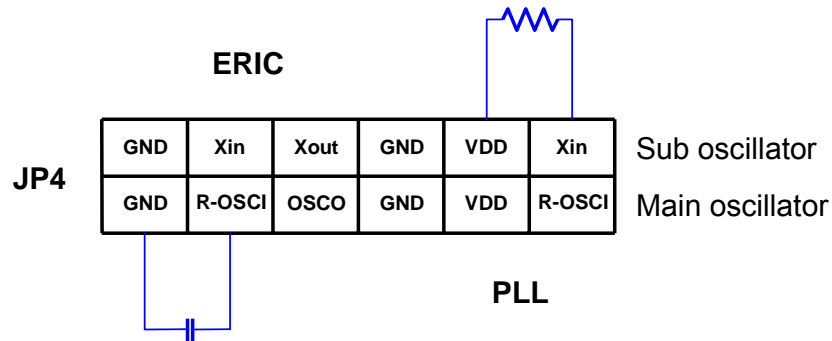

### E.6 Mode6

Main oscillator: RC mode, Sub oscillator: RC mode

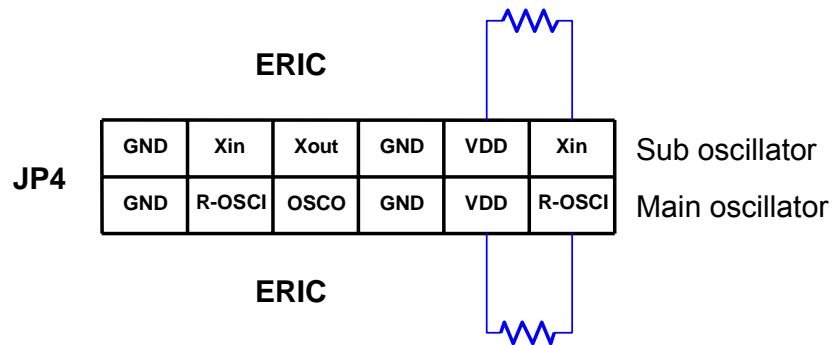

### E.7 Mode7

Main oscillator: Crystal mode, Sub oscillator: None

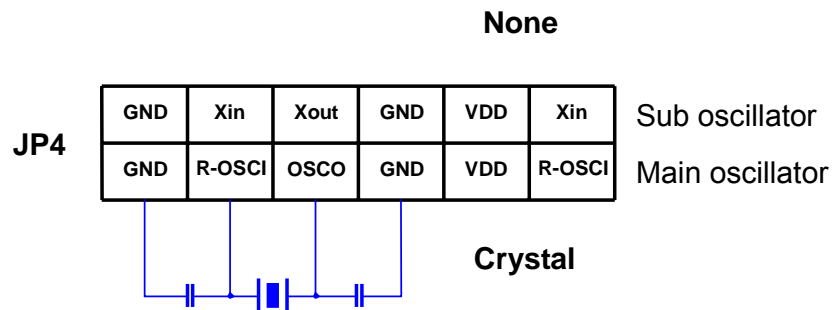



## F ICE 510 Output Pin Assignment (JP 3)

