

EM78P221/2N

**8-Bit Microcontroller
with OTP ROM**

Product Specification

DOC. VERSION 1.0

ELAN MICROELECTRONICS CORP.

March 2007



Specification Revision History

Doc. Version	Revision Description	Date
1.0	Preliminary version.	2007/03/20



1 General Description

EM78P221N and EM78P222N are 8-bit microprocessors designed and developed with low-power and high-speed CMOS technology. Each device in the series has as an on-chip 4K×13-bit Electrical One Time Programmable Read Only Memory (OTP-ROM). Each provides a protection bit to prevent intrusion of user's OTP memory code. Two Code option bits are also available to meet user's requirements.

With its enhanced OTP-ROM features, each device provides a convenient way of developing and verifying user's programs. Moreover, this OTP devices offer the advantages of easy and effective program updates, using development and programming tools. User can avail of the ELAN Writer to easily program his development code.

2 Features

- CPU configuration
 - 4K×13 bits on-chip OTP-ROM
 - 144×8 bits on-chip registers (SRAM)
 - 8-level stacks for subroutine nesting
 - 3 programmable Level Voltage Reset (LVR) : 4.0V, 3.0V, 2.5V
 - Less than 1.5 mA at 5V/4MHz
 - Typically 15 μ A, at 3V/32kHz
 - Typically 2 μ A, during sleep mode
- I/O port configuration
 - 4 bidirectional I/O ports: P5, P6, P7 and P8
 - Wake-up port : P6
 - 26 I/O pins
 - 8 programmable pull-down I/O pins
 - 8 programmable pull-high I/O pins
 - 8 programmable open-drain I/O pins
 - 16 Programmable high sink current I/O pins
 - 8 Programmable high drive current I/O pins
 - External interrupt : P77, P71
- Operating voltage range:
 - OTP version:
 - Operating voltage range: 2.1V~5.5V (commercial)
 - Operating voltage range: 2.3V~5.5V (industrial)
- Operating temperature range:
 - Operating temperature range: 0°C~70°C (commercial)
 - Operating temperature range: -40°C~85°C (industrial)
- Operating frequency range
 - Crystal mode:
 - DC~12MHz/2 clks @ 4.0V; DC~166ns inst. cycle @ 4.0V
 - DC ~ 8MHz/2 clks @ 3V; DC~250ns inst. Cycle @ 3V
 - ERC mode:
 - DC ~ 16MHz/2 clks @ 4.5V; DC~125ns inst. cycle @ 5V
 - DC ~ 8MHz/2 clks @ 3V; DC ~ 250ns inst. Cycle @ 3V
 - IRC mode:
 - Oscillation mode: 16MHz, 4 MHz, 1 MHz, 455kHz
 - Process deviation: Typ \pm 3%, Max. \pm 5%
 - Temperature deviation: \pm 5% (-40°C~85°C)

Internal RC Frequency	Drift Rate			
	Temperature (-40°C+85°C)	Voltage (2.1V~5.5V)	Process	Total
4MHz	\pm 5%	\pm 5%	\pm 4%	\pm 14%
16MHz	\pm 5%	\pm 5%	\pm 4%	\pm 14%
1MHz	\pm 5%	\pm 5%	\pm 4%	\pm 14%
455MHz	\pm 5%	\pm 5%	\pm 4%	\pm 14%

All these four main frequencies can be trimmed by programming with four calibrated bits in the ICE220N Simulator. OTP is auto trimmed by ELAN Writer (DWTR).

- Fast set-up time requires only 800 μ s (VDD:5V, Crystal: 4MHz, C1/C2: 30pF) in HXT2 mode and 64 μ s in IRC mode (VDD:5V IRC:4MHz)
- Peripheral configuration
 - 8-bit real time clock/counter (TCC) with selective signal sources, trigger edges, and overflow interrupt
 - One comparator (offset voltage is smaller than 10mV)
- Five available interrupts
 - TCC overflow interrupt
 - Input-port status changed interrupt (wake up from sleep mode)
 - Two External interrupts
 - Comparator high/low interrupt
- Special Features
 - Programmable free running Watchdog Timer
 - Two clocks per instruction cycle
 - Power-on voltage detector available (1.8 V \pm 0.1V)
 - High EFT immunity (better performance at 4MHz or below)
 - Power saving Sleep mode
 - Selectable Oscillation mode
 - Package Type:
 - 24-pin skinny DIP 300mil : EM78P221NKJ/NKS
 - 24 pin SOP 300mil : EM78P221NMJ/NMS
 - 24 pin SSOP 209mil : EM78P221NAMJ/NAMS
 - 28-pin skinny DIP 300mil : EM78P222NKJ/NKS
 - 28-pin skinny DIP 400mil : EM78P222NAKJ/NAKS
 - 28 pin SOP 300mil : EM78P222NMJ/NMS
 - 28 pin SSOP 209mil : EM78P222NAMJ/NAMS

3 Pin Assignment

(1) 28-Pin DIP/SOP/SSOP

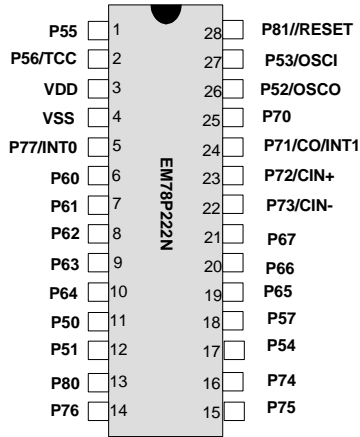

Fig. 3-1 EM78P222NK/AK/M/AM Pin Assignment

(2) 24-Pin DIP/SOP/SSOP

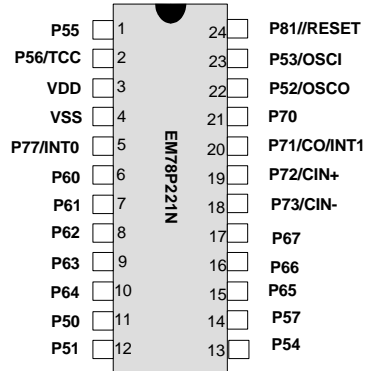

Fig. 3-2 EM78P221NK/M/AM Pin Assignment