

---

**EM78P154N**

**8-Bit Microcontroller  
with OTP ROM**

**Product  
Specification**

**DOC. VERSION 1.1**

**ELAN MICROELECTRONICS CORP.**

March 2007

---



**Trademark Acknowledgments:**

**IBM is a registered trademark and PS/2 is a trademark of IBM.**

**Windows is a trademark of Microsoft Corporation.**

**ELAN and ELAN logo  are trademarks of ELAN Microelectronics Corporation.**

Copyright © 2006~2007 by ELAN Microelectronics Corporation

**All Rights Reserved**

Printed in Taiwan

The contents of this specification are subject to change without further notice. ELAN Microelectronics assumes no responsibility concerning the accuracy, adequacy, or completeness of this specification. ELAN Microelectronics makes no commitment to update, or to keep current the information and material contained in this specification. Such information and material may change to conform to each confirmed order.

In no event shall ELAN Microelectronics be made responsible for any claims attributed to errors, omissions, or other inaccuracies in the information or material contained in this specification. ELAN Microelectronics shall not be liable for direct, indirect, special incidental, or consequential damages arising from the use of such information or material.

The software (if any) described in this specification is furnished under a license or nondisclosure agreement, and may be used or copied only in accordance with the terms of such agreement.

ELAN Microelectronics products are not intended for use in life support appliances, devices, or systems. Use of ELAN Microelectronics product in such applications is not supported and is prohibited.

**NO PART OF THIS SPECIFICATION MAY BE REPRODUCED OR TRANSMITTED IN ANY FORM OR BY ANY MEANS WITHOUT THE EXPRESSED WRITTEN PERMISSION OF ELAN MICROELECTRONICS.**



**ELAN MICROELECTRONICS CORPORATION**

**Headquarters:**

No. 12, Innovation Road 1  
Hsinchu Science Park  
Hsinchu, Taiwan 30077  
Tel: +886 3 563-9977  
Fax: +886 3 563-9966  
<http://www.emc.com.tw>

**Hong Kong:**

**Elan (HK) Microelectronics Corporation, Ltd.**  
Rm. 1005B, 10/F Empire Centre  
68 Mody Road, Tsimshatsui  
Kowloon, HONG KONG  
Tel: +852 2723-3376  
Fax: +852 2723-7780  
[elanhk@emc.com.hk](mailto:elanhk@emc.com.hk)

**USA:**

**Elan Information Technology Group (USA)**  
1821 Saratoga Ave., Suite 250  
Saratoga, CA 95070  
USA  
Tel: +1 408 366-8225  
Fax: +1 408 366-8220

**Shenzhen:**

**Elan Microelectronics Shenzhen, Ltd.**  
3F, SSMEC Bldg., Gaoxin S. Ave. I  
Shenzhen Hi-tech Industrial Park  
(South Area) Shenzhen 518057  
CHINA  
Tel: +86 755 2601-0565  
Fax: +86 755 2601-0500

**Shanghai:**

**Elan Microelectronics Shanghai, Ltd.**  
23/Bldg. #115 Lane 572, Bibo Road  
Zhangjiang Hi-Tech Park  
Shanghai, CHINA  
Tel: +86 21 5080-3866  
Fax: +86 21 5080-4600



# Contents

<b>1</b>	<b>General Description</b> .....	<b>1</b>
1.1	Comparison between EM78P154N, EM78P159N, and EM78P157N .....	1
<b>2</b>	<b>Features</b> .....	<b>1</b>
<b>3</b>	<b>Pin Assignment</b> .....	<b>2</b>
<b>4</b>	<b>Pin Description</b> .....	<b>2</b>
4.1	EM78P154NP and EM78P154NM .....	2
<b>5</b>	<b>Function Description</b> .....	<b>3</b>
5.1	Operational Registers .....	3
5.1.1	R0 (Indirect Addressing Register).....	3
5.1.2	R1 (Time Clock /Counter).....	3
5.1.3	R2 (Program Counter) & Stack.....	4
5.1.4	R3 (Status Register) .....	5
5.1.5	R4 (RAM Select Register) .....	6
5.1.6	R5 ~ R6 (Port 5 ~ Port 6).....	6
5.1.7	RD (Manual Calibration Register).....	6
5.1.8	RE (Wake Up Control Register) .....	7
5.1.9	RF (Interrupt Status Register).....	8
5.1.10	R10 ~ R3F .....	8
5.2	Special Function Registers .....	8
5.2.1	A (Accumulator) .....	8
5.2.2	CONT (Control Register) .....	8
5.2.3	IOC5 ~ IOC6 (I/O Port Control Register).....	9
5.2.4	IOCA (Prescaler Counter Register) .....	9
5.2.5	IOCB (Pull-down Control Register).....	10
5.2.6	IOCC (Open-drain Control Register) .....	10
5.2.7	IOCD (Pull-high Control Register) .....	10
5.2.8	IOCE (WDT Control Register) .....	11
5.2.9	IOCF (Interrupt Mask Register) .....	12
5.3	TCC/WDT & Prescaler.....	12
5.4	I/O Ports .....	13
5.4.1	Usage of Port 6 Input Change Wake-up/Interrupt Function .....	15
5.5	Reset and Wake-up .....	16
5.5.1	Reset .....	16
5.5.2	Summary of Registers Initialized Values .....	19
5.5.3	Status of RST, T, and P of the Status Register .....	21
5.6	Interrupt.....	22
5.7	Oscillator .....	23



5.7.1	Oscillator Modes .....	23
5.7.2	Crystal Oscillator/Ceramic Resonators (Crystal) .....	24
5.7.3	External RC Oscillator Mode .....	25
5.7.4	Internal RC Oscillator Mode .....	26
5.8	Code Option Register .....	27
5.8.1	Code Option Register (Word 0) .....	27
5.8.2	Customer ID Register (Word 1) .....	28
5.8.3	Customer ID Register (Word 2) .....	29
5.9	Power-on Considerations .....	29
5.10	External Power-on Reset Circuit .....	29
5.11	Residue-Voltage Protection .....	30
5.12	Instruction Set .....	31
5.13	Timing Diagrams .....	34
<b>6</b>	<b>Absolute Maximum Ratings .....</b>	<b>35</b>
<b>7</b>	<b>Electrical Characteristics.....</b>	<b>35</b>
7.1	DC Characteristic.....	35
7.2	AC Characteristic .....	36

## APPENDIX

<b>A</b>	<b>Package Type .....</b>	<b>37</b>
<b>B</b>	<b>Package Information .....</b>	<b>37</b>
<b>C</b>	<b>Quality Assurance and Reliability.....</b>	<b>39</b>
C.1	Reliability Test .....	39
C.2	Power-on Reset and Vdd Voltage Drop/Rise Timing Test.....	40
C.3	Address Trap Detect .....	40

### Specification Revision History

Doc. Version	Revision Description	Date
1.0	Initial Release Version	2006/05/19
1.1	Modified the operation voltage of Section 2	2007/03/29



## 1 General Description

EM78P154N is an 8-bit microprocessor designed and developed with low-power, high-speed CMOS technology. It has on-chip 1K×13-bits Electrical One Time Programmable Read Only Memory (OTP-ROM). It provides three Protection bits to prevent intrusion of user's code in the OTP memory as well as from unwanted external accesses. Eight option bits are also available to meet user's application requirements.

With its enhanced OTP-ROM features, the EM78P154N provides a convenient way of developing and verifying user's programs. Moreover, this OTP device offers the advantages of easy and effective program updates, using development and programming tools. User can avail of the ELAN Writer to easily program his development code.

### 1.1 Comparison between EM78P154N, EM78P159N, and EM78P157N

To find out the similarities and differences between EM78P154N, EM78P159N, and EM78P157N, refer to the following link: [AN-001 EM78P154N/159N Introduction and Comparison with EM78P157N](#)

## 2 Features

- CPU configuration
  - 1K×13 bits on chip ROM
  - 48×8 bits on-chip registers (SRAM, general purpose registers)
  - 5-level stacks for subroutine nesting
  - Less than 2 mA at 5V/4MHz
  - Typically 20  $\mu$ A, at 3V/32kHz
  - Typically 1  $\mu$ A, during sleep mode
- I/O port configuration
  - 2 bidirectional I/O ports
  - 4 Programmable pull-high I/O pins
  - 6 programmable pull-down I/O pins
  - 4 programmable open-drain I/O pins
  - 2 programmable R-option pins
- Operating voltage range:
  - 2.1V~5.5V at 0°C~70°C
  - 2.3V~5.5V at -40°C~85°C
- Operating frequency range (base on 2 clocks):
  - Crystal mode: DC~20MHz @ 5V, DC~8MHz @ 3V, DC~4MHz @ 2.1V
  - ERC mode: DC~4MHz @ 5V~2.1V
  - IRC mode:
    - Oscillation mode : 4MHz, 8MHz, 1MHz, 455kHz
    - Process deviation : Typ±3%, Max±5%
    - Temperature deviation : ±5% (-40°C~85°C )
    - Frequency deviation : ±4.5% after auto trimming (based on Vdd = 5V, Ta = 25°C )
- Fast set-up time requires only 2ms in high Crystal and 32 CLKs in IRC mode from wake up to operating mode
- Peripheral configuration
  - 8-bit real time clock/counter (TCC) with selective signal sources, trigger edges, and overflow interrupt
- One security register to prevent intrusion of OTP memory codes
- One configuration register to accommodate user's requirements
- Two clocks per instruction cycle
- Power down (Sleep) mode
- Three available interrupts:
  - TCC overflow interrupt
  - Input-port status changed interrupt (wake-up from sleep mode)
  - External interrupt
- Special features
  - Programmable free running watchdog timer
  - Single instruction cycle commands
- Package types:
  - 14-pin DIP 300mil : EM78P154NP
  - 14-pin SOP 150mil : EM78P159NM

The transient point of system frequency between HXT and LXT is 400kHz.

All these four main frequencies can be trimmed by programming with four calibrated bits in the ICE159N Simulator. OTP is auto trimmed by ELAN Writer (DWTR)

### 3 Pin Assignment

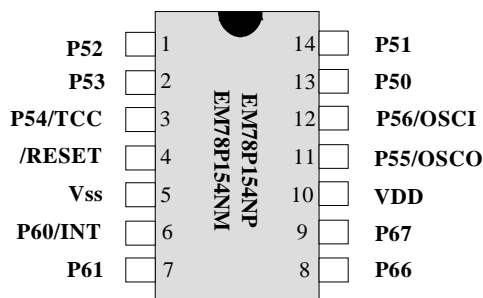

Figure 3-1a EM78P154NP/M Pin Assignment

### 4 Pin Description

#### 4.1 EM78P154NP and EM78P154NM

Symbol	Pin No.	Type	Function
P60, P61 P66, P67	7, 8 13, 14	I/O	P60 ~ P67 are bi-directional I/O pins. These can be pulled-high or can be open-drain by software programming. P60 ~ P61 can also be pulled-down by software
P56/OSCI	16	I/O	General-purpose I/O pin Crystal type: Crystal input terminal or external clock input pin ERC type: RC oscillator input pin
P55/OSCO	15	I/O	General-purpose I/O pin Crystal type: Output terminal for crystal oscillator or external clock input pin RC type: Instruction clock output External clock signal input
P54/TCC	3	I/O	General-purpose I/O pin Real time clock/counter (with Schmitt trigger input pin), must be tied to VDD or VSS if not in use.
P50 ~ P53	17, 18, 1, 2	I/O	P50 ~ P53 are bidirectional I/O pins, can also be pulled-down by software P50 and P51 can also be defined as R-option pins
/RESET	4	I	Input pin with Schmitt trigger. If this pin remains at logic low, the controller will also remain in reset condition.
/INT	6	I	External interrupt pin triggered by a falling edge
VDD	14	-	Power supply
VSS	5	-	Ground

## 5 Function Description

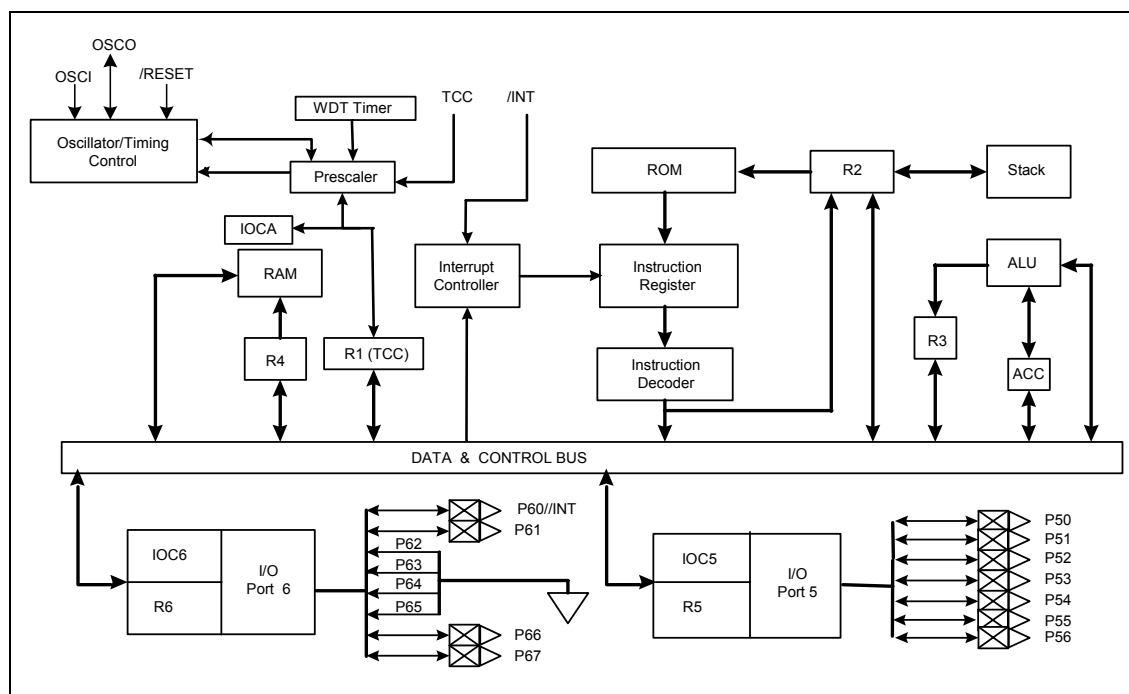

Figure 5-1 Function Block Diagram

### 5.1 Operational Registers

#### 5.1.1 R0 (Indirect Addressing Register)

R0 is not a physically implemented register. It is used as an indirect addressing pointer. Any instruction using R0 as a pointer actually accesses data pointed by the RAM Select Register (R4).

#### 5.1.2 R1 (Time Clock /Counter)

- Incremented by an external signal edge, which is defined by TE bit (CONT-4) through the TCC pin, or by the instruction cycle clock.
- Writable and readable as any other registers.
- Defined by resetting PAB (CONT-3).
- The prescaler is assigned to TCC, if the PAB bit (CONT-3) is reset.
- The contents of the prescaler counter will be cleared only when TCC register is written with a value.

### 5.1.3 R2 (Program Counter) & Stack

- Depending on the device type, R2 and hardware stack are 10-bit wide. The structure is depicted in the following figure.

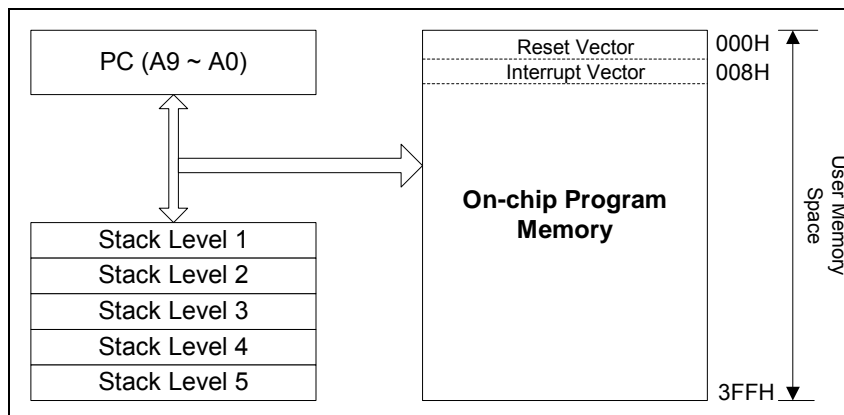

Figure 5-2 Program Counter Organization

- The configuration structure generates 1024×13 bits on-chip OTP ROM addresses to the relative programming instruction codes. One program page is 1024 words long.
- R2 is set as all "0" when under RESET condition.
- "JMP" instruction allows direct loading of the lower 10 program counter bits. Thus, "JMP" allows PC to go to any location within a page.
- "CALL" instruction loads the lower 10 bits of the PC, and then PC+1 is pushed into the stack. Thus, the subroutine entry address can be located anywhere within a page.
- "RET" ("RETLk", "RETI") instruction loads the program counter with the contents of the top-level stack.
- "ADD R2, A" allows a relative address to be added to the current PC, and the ninth and succeeding bits of the PC will increase progressively.
- "MOV R2, A" allows loading of an address from the "A" register to the lower 8 bits of the PC, and the ninth and tenth bits (A8 ~ A9) of the PC will remain unchanged.
- Any instruction (except "ADD R2,A") that is written to R2 (e.g., "MOV R2, A", "BC R2, 6",.....) will cause the ninth bit and the tenth bit (A8 ~ A9) of the PC to remain unchanged.
- All instructions are single instruction cycle (fclk/2 or fclk/4) except for the instruction that would change the contents of R2. Such instruction will need one more instruction cycle.



- The Data Memory Configuration is as follows:

Address	R PAGE Registers	IOC PAGE Registers
00	R0 (IAR)	Reserve
01	R1 (TCC)	CONT (Control Register)
02	R2 (PC)	Reserve
03	R3 (Status)	Reserve
04	R4 (RSR)	Reserve
05	R5 (Port 5)	IOC5 (I/O Port Control Register)
06	R6 (Port 6)	IOC6 (I/O Port Control Register)
07	Reserve	Reserve
08	Reserve	Reserve
09	Reserve	Reserve
0A	Reserve	IOCA (Prescaler Control Register)
0B	Reserve	IOCB (Pull-down Register)
0C	Reserve	IOCC (Open-drain Control)
0D	RD (Only for simulator)	IOCD (Pull-high Control Register)
0E	RE (Wake-up control)	IOCE (WDT Control Register)
0F	RF (Interrupt Status)	IOCF (Interrupt Mask Register)
10 : 3F	General Registers	

#### 5.1.4 R3 (Status Register)

Bit 7	Bit 6	Bit 5	Bit 4	Bit 3	Bit 2	Bit 1	Bit 0
GP2	GP1	GP0	T	P	Z	DC	C

**Bit 0 (C):** Carry flag

**Bit 1 (DC):** Auxiliary carry flag

**Bit 2 (Z):** Zero flag

Set to "1" if the result of an arithmetic or logic operation is zero.

**Bit 3 (P):** Power down bit

Set to "1" during power on or by a "WDTC" command; and reset to "0" by a "SLEP" command.

**Bit 4 (T):** Time-out bit

Set to "1" with the "SLEP" and "WDTC" commands, or during power up; and reset to "0" by WDT time-out.

**Bits 5 ~7 (GP0 ~ 2):** General-purpose read/write bits



### 5.1.5 R4 (RAM Select Register)

**Bits 0 ~ 5:** are used to select registers (Address: 00~06, 0F~3F) in the indirect addressing mode.

**Bits 6 ~ 7:** Not used (read only), but need to set to “1” all the time to avoid possible error.

The “Z” flag of R3 will be set to “1” when the R4 content is equal to “3F.” When R4=R4+1, the R4 content will select “R0.”

### 5.1.6 R5 ~ R6 (Port 5 ~ Port 6)

R5 and R6 are I/O registers.

#### ■ Port 5

Bit 7	Bit 6	Bit 5	Bit 4	Bit 3	Bit 2	Bit 1	Bit 0
-	P56	P55	P54	P53	P52	P51	P50

**Bit 7:** Not used.

#### ■ Port 6

Bit 7	Bit 6	Bit 5	Bit 4	Bit 3	Bit 2	Bit 1	Bit 0
P66	P65	-	-	-	-	P61	P60

**Bits 2 ~ 5:** Not used.

### 5.1.7 RD (Manual Calibration Register)

	Bit 7	Bit 6	Bit 5	Bit 4	Bit 3	Bit 2	Bit 1	Bit 0
EM78P154N	×	×	×	×	×	×	×	×
ICE159N Simulator	-	-	-	-	C3	C2	C1	C0

In **EM78P154N**, the register does not exist in actual chip.

In **ICE159N Simulator**, **C3 ~ C0** are IRC calibration bits in MCIRC mode.



**Bit 3 ~ Bit 0 (C3 ~ C0):** calibration bits in internal RC mode

C3	C2	C1	C0	Cycle Time (ns)	Frequency (MHz)
0	0	0	0	390.6	2.56
0	0	0	1	365.0	2.74
0	0	1	0	342.5	2.92
0	0	1	1	322.6	3.1
0	1	0	0	304.9	3.28
0	1	0	1	289.0	3.46
0	1	1	0	274.7	3.64
0	1	1	1	261.8	3.82
1	1	1	1	250.0	4.00
1	1	1	0	239.2	4.18
1	1	0	1	229.4	4.36
1	1	0	0	220.3	4.54
1	0	1	1	211.9	4.72
1	0	1	0	204.1	4.9
1	0	0	1	196.7	5.08
1	0	0	0	190.1	5.26

**NOTE:**

1. Frequency values shown are theoretical and taken from an instance of a high frequency mode. Hence they are shown for reference only. Definite values will depend on the actual process.
2. Similar way of calculation is also applicable for Low Frequency mode.

**Bits 4 ~ 7:** Not used

### 5.1.8 RE (Wake-up Control Register)

Bit 7	Bit 6	Bit 5	Bit 4	Bit 3	Bit 2	Bit 1	Bit 0
-	-	-	-	-	-	ICWE	-

**Bits 0:** Not used.

**Bit 1 (ICWE):** Port 6 input status change wake-up enable bit

0 = Disable Port 6 input status change wake-up

1 = Enable Port 6 input status change wake-up

**Bits 2 ~ 7:** Not used.



### 5.1.9 RF (Interrupt Status Register)

Bit 7	Bit 6	Bit 5	Bit 4	Bit 3	Bit 2	Bit 1	Bit 0
-	-	-	-	-	EXIF	ICIF	TCIF

Note: "1" means with interrupt request "0" means no interrupt occurs

**Bit 0 (TCIF):** TCC overflow interrupt flag. Set when TCC overflows. Reset by software.

**Bit 1 (ICIF):** Port 6 input status change interrupt flag. Set when Port 6 input changes. Reset by software.

**Bit 2 (EXIF):** External interrupt flag. Set by a falling edge on /INT pin. Reset by software.

**Bits 3 ~ 7:** Not used

RF can be cleared by instruction but cannot be set.

IOCF is the interrupt mask register.

**NOTE**  
The result of reading RF is the "logic AND" of RF and IOCF.

### 5.1.10 R10 ~ R3F

These are all 8-bit general-purpose registers.

## 5.2 Special Function Registers

### 5.2.1 A (Accumulator)

Internal data transfer operation, or instruction operand holding usually involves the temporary storage function of the Accumulator, which is not an addressable register.

### 5.2.2 CONT (Control Register)

Bit 7	Bit 6	Bit 5	Bit 4	Bit 3	Bit 2	Bit 1	Bit 0
-	/INT	TS	TE	PSRE	PSR2	PSR1	PSR0

**Bit 0 (PSR0) ~ Bit 2 (PSR2):** TCC prescaler bits

PSR2	PSR1	PSR0	TCC Rate
0	0	0	1:2
0	0	1	1:4
0	1	0	1:8
0	1	1	1:16
1	0	0	1:32
1	0	1	1:64
1	1	0	1:128
1	1	1	1:256



**Bit 3 (PSRE):** Prescaler enable bit for TCC

0 = prescaler disabled bit, TCC rate is 1:1

1 = prescaler enabled bit, TCC rate is set as Bit 2~Bit 0

**Bit 4 (TE):** TCC signal edge

0 = increment if the transition from low to high takes place on the TCC pin

1 = increment if the transition from high to low takes place on the TCC pin

**Bit 5 (TS):** TCC signal source

0 = internal instruction cycle clock, P54 is a bidirectional I/O pin

1 = transition on TCC pin

**Bit 6 (/INT):** Interrupt enable flag

0 = masked by DISI or hardware interrupt

1 = enabled by ENI/RETI instructions

**Bit 7:** Not used

CONT register is both readable and writable.

### 5.2.3 IOC5 ~ IOC6 (I/O Port Control Register)

0 = defines the relative I/O pin as output

1 = puts the relative I/O pin into high impedance

#### ■ Port 5

Bit 7	Bit 6	Bit 5	Bit 4	Bit 3	Bit 2	Bit 1	Bit 0
-	IOC56	IOC55	IOC54	IOC53	IOC52	IOC51	IOC50

**Bit 7** Not used

#### ■ Port 6

Bit 7	Bit 6	Bit 5	Bit 4	Bit 3	Bit 2	Bit 1	Bit 0
IOC66	IOC65	-	-	-	-	IOC61	IOC60

**Bits 2 ~ 5** Not used.

IOC5 and IOC6 registers are both readable and writable.

### 5.2.4 IOCA (Prescaler Counter Register)

The IOCA register is readable. The value of IOCA is equal to the contents of the Prescaler counter. It is a Down counter register.



### 5.2.5 IOCB (Pull-down Control Register)

Bit 7	Bit 6	Bit 5	Bit 4	Bit 3	Bit 2	Bit 1	Bit 0
-	-	/PD5	/PD4	/PD3	/PD2	/PD1	/PD0

**Bit 0 (/PD0):** Control bit is used to enable the pull-down of P50 pin.

0 = Enable internal pull-down

1 = Disable internal pull-down

**Bit 1 (/PD1):** Control bit used to enable the P51 pull-down pin

**Bit 2 (/PD2):** Control bit used to enable the P52 pull-down pin

**Bit 3 (/PD3):** Control bit used to enable the P53 pull-down pin

**Bit 4 (/PD4):** Control bit used to enable the P60 pull-down pin

**Bit 5 (/PD5):** Control bit used to enable the P61 pull-down pin

**Bits 6 ~ 7):** Not used

The IOCB Register is both readable and writable.

### 5.2.6 IOCC (Open-drain Control Register)

Bit 7	Bit 6	Bit 5	Bit 4	Bit 3	Bit 2	Bit 1	Bit 0
OD7	OD6	-	-	-	-	OD1	OD0

**Bit 0 (OD0):** Control bit used to enable the P60 open-drain pin

0 = Disable open-drain output

1 = Enable open-drain output

**Bit 1 (OD1):** Control bit used to enable the P61 open-drain pin

**Bit 6 (OD6):** Control bit used to enable the P66 open-drain pin

**Bit 7 (OD7):** Control bit used to enable the P67 open-drain pin

**Bits 2~5:** Not used

The IOCC Register is both readable and writable.

### 5.2.7 IOCD (Pull-high Control Register)

Bit 7	Bit 6	Bit 5	Bit 4	Bit 3	Bit 2	Bit 1	Bit 0
/PH7	/PH6	-	-	-	-	/PH1	/PH0

**Bit 0 (/PH0):** Control bit used to enable the P60 pull-high pin

0 = Enable internal pull-high

1 = Disable internal pull-high

**Bit 1 (/PH1):** Control bit used to enable the P61 pull-high pin

**Bit 6 (/PH6):** Control bit is used to enable the pull-high of P66 pin.

**Bit 7 (/PH7):** Control bit is used to enable the pull-high of P67 pin.

**Bits 2~5:** Not used

The IOCD Register is both readable and writable.



### 5.2.8 IOCE (WDT Control Register)

Bit 7	Bit 6	Bit 5	Bit 4	Bit 3	Bit 2	Bit 1	Bit 0
WDTE	EIS	-	ROC	PSWE	PSW2	PSW1	PSW0

**Bit 7 (WDTE):** Control bit used to enable the Watchdog timer.

0 = Disable WDT

1 = Enable WDT

WDTE is both readable and writable.

**Bit 6 (EIS):** Control bit is used to define the function of P60 (/INT) pin.

0 = P60, bidirectional I/O pin.

1 = /INT, external interrupt pin. In this case, the I/O control bit of P60 (Bit 0 of IOC6) must be set to "1."

When EIS is "0," the path of /INT is masked. When EIS is "1," the status of /INT pin can also be read by way of reading Port 6 (R6). See Figure 4-4a under Section 4.4 for reference.

EIS is both readable and writable.

**Bit 5:** Not used

**Bit 4 (ROC):** ROC is used for the R-option

Setting the ROC to "1" will enable the status of R-option pins (P50~P51) that are read by the controller. Clearing the ROC will disable the R-option function. If the R-option function is selected, you must connect the P51 pin or/and P50 pin to VSS with a 430KΩ external resistor (Rex). If the Rex is connected/disconnected, the status of P50 (P51) is read as "0" / "1." Refer to Figure 4-5 under Section 4.4 for reference.

**Bit 3 (PSWE):** Prescaler enable bit for WDT

0 = prescaler disable bit, WDT rate is 1:1

1 = prescaler enable bit, WDT rate is set as Bit 4~Bit 2

**Bit 2 (PSW2) ~ Bit 0 (PSW0):** WDT prescaler bits

PSW2	PSW1	PSW0	WDT Rate
0	0	0	1:2
0	0	1	1:4
0	1	0	1:8
0	1	1	1:16
1	0	0	1:32
1	0	1	1:64
1	1	0	1:128
1	1	1	1:256



### 5.2.9 IOCF (Interrupt Mask Register)

Bit 7	Bit 6	Bit 5	Bit 4	Bit 3	Bit 2	Bit 1	Bit 0
-	-	-	-	-	EXIE	ICIE	TCIE

**Bit 0 (TCIE):** TCIF interrupt enable bit

0 = disable TCIF interrupt

1 = enable TCIF interrupt

**Bit 1 (ICIE):** ICIF interrupt enable bit

0 = disable ICIF interrupt

1 = enable ICIF interrupt

**Bit 2 (EXIE):** EXIF interrupt enable bit

0 = disable EXIF interrupt

1 = enable EXIF interrupt

**Bits 3~7:** Not used

Individual interrupt is enabled by setting its associated control bit in the IOCF to "1."

Global interrupt is enabled by the ENI instruction and disabled by the DISI instruction.

Refer to Figure 5-7 in Section 5.6 for further reference.

The IOCF register is both readable and writable.

## 5.3 TCC/WDT & Prescaler

There are two 8-bit counters available as prescalers for TCC and WDT respectively. The PSR0 ~ PSR2 bits of the CONT register are used to determine the ratio of the prescaler of TCC, and the PWR0 ~ PWR2 bits of the IOCE register are used to determine the prescaler of WDT. The prescaler (PSR0 ~ PSR2) will be cleared by the instruction each time it writes to TCC. The WDT and prescaler will be cleared by the "WDTC" and "SLEP" instructions.

- R1 (TCC) is an 8-bit timer/counter. The clock source of TCC can be internal or external clock input (edge selectable from TCC pin). If TCC signal is sourced from internal clock, TCC will increase by 1 at every instruction cycle (without prescaler).  $CLK = F_{osc}/2$  or  $CLK = F_{osc}/4$  application is determined by the CODE Option bit CLK status.  $CLK = F_{osc}/2$  is used if CLK bit is "0," and  $CLK = F_{osc}/4$  is used if CLK bit is "1." If TCC signal source comes from external clock input, TCC is increased by 1 at every falling edge or rising edge of TCC pin.
- The watchdog timer is a free running on-chip RC oscillator. The WDT will keep on running even when the oscillator driver has been turned off (i.e., in Sleep mode). During normal operation or Sleep mode, a WDT time-out (if enabled) will cause the device to reset. The WDT can be enabled or disabled any time during Normal mode by software programming. Refer to WDTE bit of IOCE register in Section 4.2.8. Without prescaler, the WDT time-out period is approximately 18 ms<sup>1</sup> (default).

<sup>1</sup> Vdd = 5V, set up time period = 16.8ms ± 30%  
Vdd = 3V, set up time period = 18ms ± 30%

## 5.4 I/O Ports

The I/O registers, both Port 5 and Port 6, are bi-directional tri-state I/O ports. Port 6 can be pulled high internally by software. In addition, Port 6 can also features an open-drain output through software and an Input status change interrupt (or wake-up) function. P50 ~ P53 and P60 ~ P61 pins can be pulled down by software. Each I/O pin can be defined as "input" or "output" pin by the I/O control register (IOC5 ~ IOC6). P50~P51 are the R-option pins enabled by setting the ROC bit in the IOCE register to "1." When the R-option function is used, it is recommended that P50 ~ P51 are used as output pins. When R-option is in enable state, P50 ~ P51 must be programmed as input pins. In R-option mode, the current/power consumption by Rex should be taken into the consideration to promote energy conservation.

The I/O registers and I/O control registers are both readable and writable. The I/O interface circuits for Port 5 and Port 6 are shown in the following figures (Figures 5-3, 5-4a, 5-4b, & 5-5).

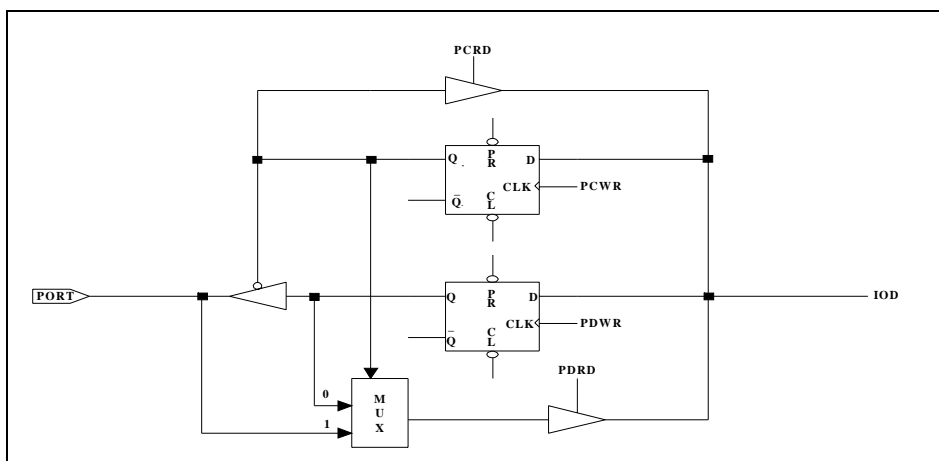

**Note:** Pull-down is not shown in the figure.

*Figure 5-3 I/O Port and I/O Control Register for Port 5 Circuit*



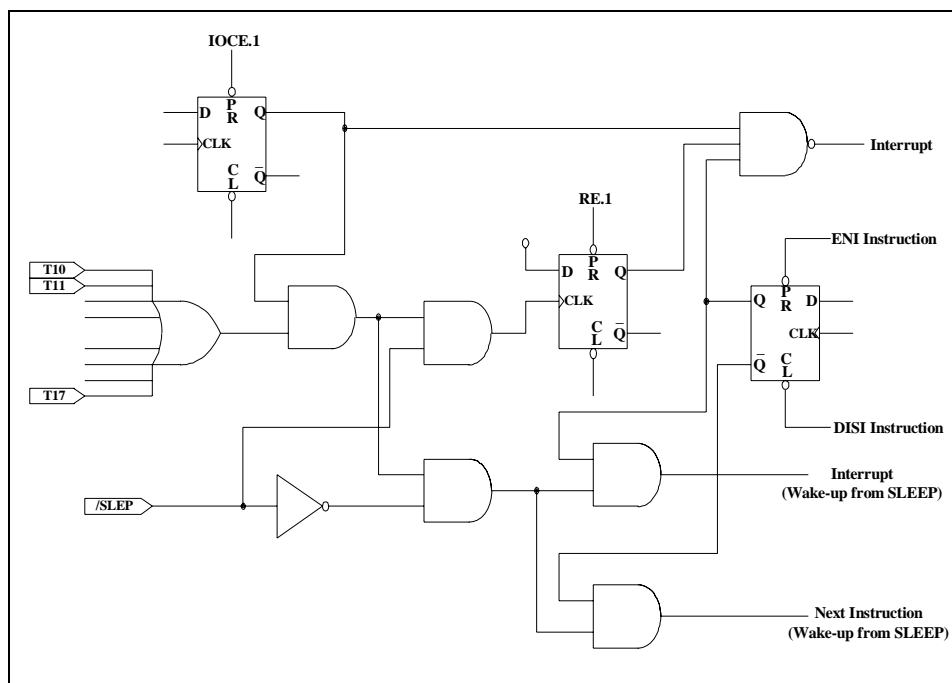

Figure 5-4c I/O Port 6 with Input Change Interrupt/Wake-up Block Diagram

### 5.4.1 Usage of Port 6 Input Status Changed Wake-up/Interrupt Function

Usage of Port 6 Input Status Changed Wake-up/Interrupt	
(I) Wake-up	(II) Wake-up and interrupt
(a) Before Sleep	(a) Before Sleep
1. Disable WDT	1. Disable WDT
2. Read I/O Port 6 (MOV R6,R6)	2. Read I/O Port 6 (MOV R6,R6)
3. Execute "ENI" or "DISI"	3. Execute "ENI" or "DISI"
<b>4. Enable wake-up bit (Set RE ICWE =1)</b>	<b>4. Enable wake-up bit (Set RE ICWE =1)</b>
5. Execute "SLEP" instruction	<b>5. Enable interrupt (Set IOCF ICIE =1)</b>
(b) After wake-up	6. Execute "SLEP" instruction
→ Next instruction	(b) After wake-up
	1. IF "ENI" → Interrupt vector (008H)
	2. IF "DISI" → Next instruction
(III) Interrupt	
(a) Before Port 6 pin change	
1. Read I/O Port 6 (MOV R6,R6)	
2. Execute "ENI" or "DISI"	
<b>3. Enable interrupt (Set IOCF0 ICIE =1)</b>	
(b) After Port 6 pin changed (interrupt)	
1. IF "ENI" → Interrupt vector (008H)	
2. IF "DISI" → Next instruction	

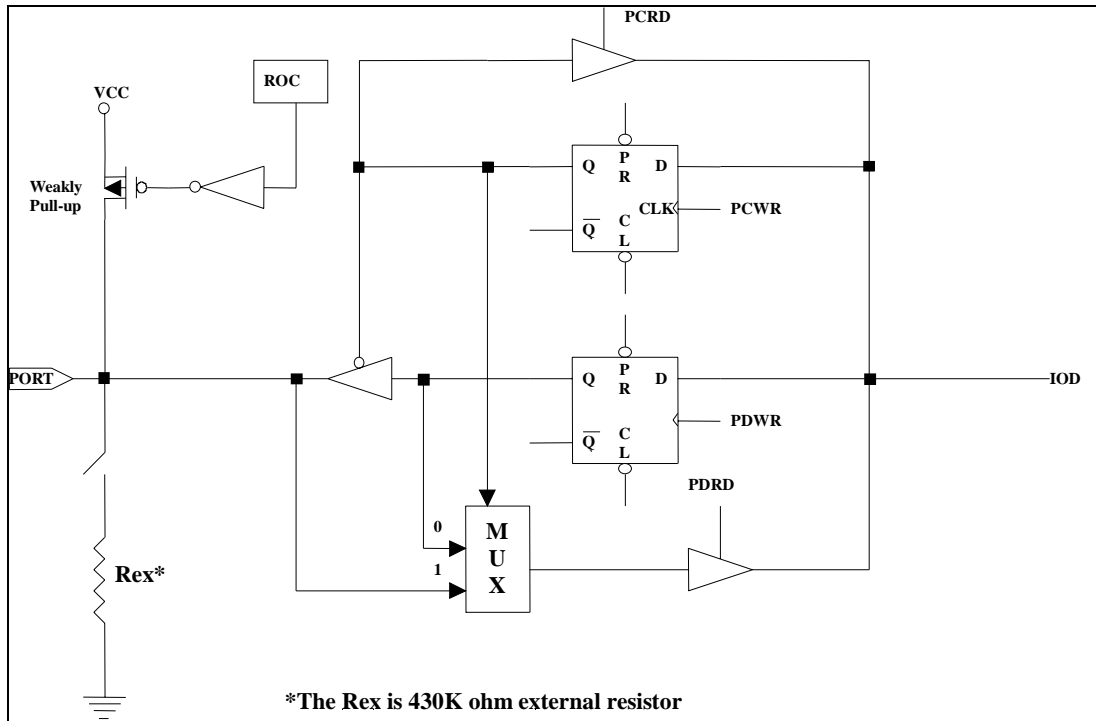

Figure 5-5 I/O Port with R-option (P50,P51) Circuit

## 5.5 Reset and Wake-up

### 5.5.1 Reset

A Reset is initiated by one of the following events:

- 1) Power on reset
- 2) /RESET pin input "low"
- 3) WDT time-out (if enabled)

The device is kept under reset condition for a period of approximately 18ms<sup>2</sup> (one oscillator start-up timer period) after a reset is detected. And if the /Reset pin goes "low" or WDT time-out is active, a reset is generated. Once a Reset occurs, the following functions are performed:

- The oscillator is running, or will be started.
- The Program Counter (R2) is set to all "0."
- All I/O port pins are configured as input mode (high-impedance state)

<sup>2</sup> Vdd = 5V, set up time period = 16.8ms ± 30%  
Vdd = 3V, set up time period = 18ms ± 30%



- The Watchdog timer and prescaler are cleared.
- When power is switched on, the upper 3 bits of R3 are cleared.
- The bits of the CONT register are set to all "1" except for Bit 6 (INT flag).
- The bits of the IOCA register are set to all "1."
- The bits of the IOCB register are set to all "1."
- The IOCC register is cleared.
- The bits of the IOCD register are set to all "1."
- Bit 7 of the IOCE register is set to "1," and Bits 4 and 6 are cleared.
- Bits 0 ~ 2 of RF and Bits 0 ~ 2 of IOCF registers are cleared.

The Sleep (power down) mode is asserted by executing the "SLEP" instruction. While entering Sleep mode, WDT (if enabled) is cleared but keeps on running. The controller can be awakened by-

- 1) External reset input on /RESET pin,
- 2) WDT time-out (if enabled)
- 3) Port 6 input status change (if enabled)

The first two cases will cause the EM78P154N to reset. The T and P flags of R3 are used to determine the source of the reset (wake-up). The last case is considered the continuation of program execution and the global interrupt ("ENI" or "DISI" being executed) decides whether or not the controller branches to the interrupt vector following wake-up. If ENI is executed before SLEP, the instruction will begin to execute from the address 008H after wake-up. If DISI is executed before SLEP, the operation will restart from the succeeding instruction right next to SLEP after wake-up.

Wake up time is dependent on oscillator mode. In RC mode, the reset time is 32 clocks, and in High Crystal mode, reset time is 2ms and 32 clocks. In low Crystal mode, the reset time is 500ms. This is applicable only for stable oscillator.

Only one of Cases 2 and 3 can be enabled before going into the Sleep mode. That is,

**[a]** if Port 6 Input Status Change Interrupt is enabled before SLEP, WDT must be disabled by software. However, the WDT bit in the option register remains enabled. Hence, the EM78P154N can be awakened only by Case 1 or Case 3.

**[b]** if WDT is enabled before SLEP, Port 6 Input Status Change Interrupt must be disabled. Hence, the EM78P154N can be awakened only by Case 1 or Case 2. Refer to Section 5.6, *Interrupt* for further details.



If Port 6 Input Status Change Interrupt is used to wake-up the EM78P154N (Case [a] above), the following instructions must be executed before SLEP:

```
WDTC                ; Clear WDT and prescaler
MOV A, @0xxxxxxx    ; Disable WDT and Select WDT prescaler
IOW IOCE
MOV R6, R6          ; Read Port 6
BS RE,1            ; Enable wake up control bit
MOV A, @00000x1xb  ; Enable Port 6 input change interrupt
IOW IOCF
ENI (or DISI)      ; Enable (or disable) global interrupt
SLEP               ; Sleep
NOP
```



### 5.5.2 Summary of Registers Initialized Values

Address	Name	Reset Type	Bit 7	Bit 6	Bit 5	Bit 4	Bit 3	Bit 2	Bit 1	Bit 0
N/A	IOC5	Bit Name	×	C56	C55	C54	C53	C52	C51	C50
		Power-on	U	1	1	1	1	1	1	1
		/RESET and WDT	U	1	1	1	1	1	1	1
		Wake-up from Pin Change	U	P	P	P	P	P	P	P
N/A	IOC6	Bit Name	C67	C66	×	×	×	×	C61	C60
		Power-on	1	1	U	U	U	U	1	1
		/RESET and WDT	1	1	U	U	U	U	1	1
		Wake-up from Pin Change	P	P	U	U	U	U	P	P
N/A	CONT	Bit Name	×	/INT	TS	TE	PSRE	PSR2	PSR1	PSR0
		Power-on	1	0	1	1	1	1	1	1
		/RESET and WDT	1	0	1	1	1	1	1	1
		Wake-up from Pin Change	P	P	P	P	P	P	P	P
0x00	R0 (IAR)	Bit Name	-	-	-	-	-	-	-	-
		Power-on	U	U	U	U	U	U	U	U
		/RESET and WDT	P	P	P	P	P	P	P	P
		Wake-up from Pin Change	P	P	P	P	P	P	P	P
0x01	R1 (TCC)	Bit Name	-	-	-	-	-	-	-	-
		Power-on	0	0	0	0	0	0	0	0
		/RESET and WDT	0	0	0	0	0	0	0	0
		Wake-up from Pin Change	P	P	P	P	P	P	P	P
0x02	R2 (PC)	Bit Name	-	-	-	-	-	-	-	-
		Power-on	0	0	0	0	0	0	0	0
		/RESET and WDT	0	0	0	0	0	0	0	0
		Wake-up from Pin Change	*0/P	*0/P	*0/P	*0/P	*1/P	*0/P	*0/P	*0/P
0x03	R3 (SR)	Bit Name	GP2	GP1	GP0	T	P	Z	DC	C
		Power-on	0	0	0	1	1	U	U	U
		/RESET and WDT	0	0	0	**	**	P	P	P
		Wake-up from Pin Change	P	P	P	**	**	P	P	P
0x04	R4 (RSR)	Bit Name	-	-	-	-	-	-	-	-
		Power-on	1	1	U	U	U	U	U	U
		/RESET and WDT	1	1	P	P	P	P	P	P
		Wake-up from Pin Change	1	1	P	P	P	P	P	P
0x05	P5	Bit Name	×	P56	P55	P54	P53	P52	P51	P50
		Power-on	0	U	U	U	U	U	U	U
		/RESET and WDT	0	P	P	P	P	P	P	P
		Wake-up from Pin Change	0	P	P	P	P	P	P	P
0x06	P6	Bit Name	P67	P66	×	×	×	×	P61	P60
		Power-on	U	U	0	0	0	0	U	U
		/RESET and WDT	P	P	0	0	0	0	P	P
		Wake-up from Pin Change	P	P	0	0	0	0	P	P



Address	Name	Reset Type	Bit 7	Bit 6	Bit 5	Bit 4	Bit 3	Bit 2	Bit 1	Bit 0
0x0E	RE (WUE)	Bit Name	x	x	x	x	x	x	ICWE	x
		Power-on	U	U	U	U	U	U	0	U
		/RESET and WDT	U	U	U	U	U	U	0	U
		Wake-up from Pin Change	U	U	U	U	U	U	P	U
0x0F	RF(ISR)	Bit Name	x	x	x	x	x	EXIF	ICIF	TCIF
		Power-on	U	U	U	U	U	0	0	0
		/RESET and WDT	U	U	U	U	U	0	0	0
		Wake-up from Pin Change	U	U	U	U	U	P	P	P
0x0A	IOCA	Bit Name	-	-	-	-	-	-	-	-
		Power-on	1	1	1	1	1	1	1	1
		/RESET and WDT	1	1	1	1	1	1	1	1
		Wake-up from Pin Change	P	P	P	P	P	P	P	P
0x0B	IOCB	Bit Name	x	x	/PD5	/PD4	/PD3	/PD2	/PD1	/PD0
		Power-on	1	1	1	1	1	1	1	1
		/RESET and WDT	1	1	1	1	1	1	1	1
		Wake-up from Pin Change	P	P	P	P	P	P	P	P
0x0C	IOCC	Bit Name	OD7	OD6	x	x	x	x	OD1	OD0
		Power-on	0	0	0	0	0	0	0	0
		/RESET and WDT	0	0	0	0	0	0	0	0
		Wake-up from Pin Change	P	P	P	P	P	P	P	P
0x0D	IOCD	Bit Name	/PH7	/PH6	x	x	x	x	/PH1	/PH0
		Power-on	1	1	1	1	1	1	1	1
		/RESET and WDT	1	1	1	1	1	1	1	1
		Wake-up from Pin Change	P	P	P	P	P	P	P	P
0x0E	IOCE	Bit Name	WDTE	EIS	x	ROC	PSWE	PSW2	PSW1	PSW0
		Power-on	1	0	U	0	0	0	0	0
		/RESET and WDT	1	0	U	0	0	0	0	0
		Wake-up from Pin Change	1	P	U	P	P	P	P	P
0x0F	IOCF	Bit Name	x	x	x	x	x	EXIE	ICIE	TCIE
		Power-on	U	U	U	U	U	0	0	0
		/RESET and WDT	U	U	U	U	U	0	0	0
		Wake-up from Pin Change	U	U	U	U	U	P	P	P
0x10~0x2F	R10~R2F	Bit Name	-	-	-	-	-	-	-	-
		Power-on	U	U	U	U	U	U	U	U
		/RESET and WDT	P	P	P	P	P	P	P	P
		Wake-up from Pin Change	P	P	P	P	P	P	P	P

**Legend:**

X: Not used    U: Unknown or don't care    P: Previous value before reset

\* Jump to Address 0x08, or execute the instruction next to the "SLEP" instruction.

\*\* Refer to tables provided in the next section (Section 5.5.3).

### 5.5.3 Status of RST, T, and P of the Status Register

A Reset condition is initiated by the following events

- 1) A power-on condition
- 2) A high-low-high pulse on /RESET pin
- 3) Watchdog timer time-out

The values of T and P listed in the table below are used to check how the processor wakes up.

#### ■ The Values of RST, T, and P after a Reset

Reset Type	T	P
Power on	1	1
/RESET during Operating mode	*P	*P
/RESET wake-up during Sleep mode	1	0
WDT during Operating mode	0	*P
WDT wake-up during Sleep mode	0	0
Wake-Up on pin change during Sleep mode	1	0

\* P: Previous status before reset

The following table shows the events that may affect the status of T and P.

#### ■ The Status of T and P Being Affected by Events

Event	T	P
Power on	1	1
WDTC instruction	1	1
WDT time-out	0	*P
SLEP instruction	1	0
Wake-up on pin change during Sleep mode	1	0

\* P: Previous status before reset

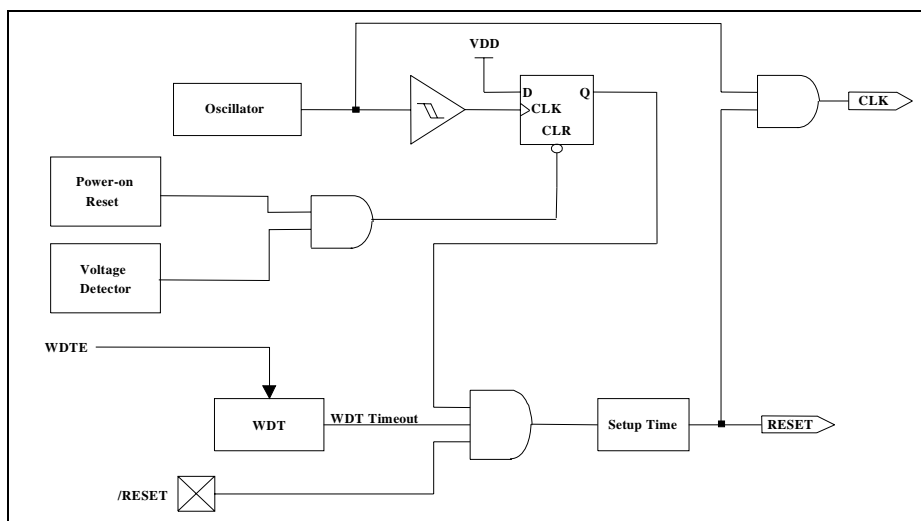

Figure 5-6 Controller Reset Block Diagram



## 5.6 Interrupt

The EM78P154N has three falling-edge interrupts as listed herewith:

- 1) TCC overflow interrupt
- 2) Port 6 Input Status Change Interrupt
- 3) External interrupt [(P60, /INT) pin]

Before the Port 6 Input Status Change Interrupt is enabled, reading Port 6 (e.g., "MOV R6,R6") is necessary. Each Port 6 pin will have this feature if its status changes. Any pin configured as output or P60 pin configured as /INT is excluded from this function. The Port 6 Input Status Changed Interrupt can wake up the EM78P154N from Sleep mode if Port 6 is enabled prior to going into the Sleep mode by executing SLEP. When the chip wakes-up, the controller will continue to execute the succeeding address if the global interrupt is disabled or it will branch into the interrupt vector 008H if the global interrupt is enabled.

RF is the interrupt status register that records the interrupt requests in the relative flags/bits. IOCF is an interrupt mask register. The global interrupt is enabled by the ENI instruction and is disabled by the DISI instruction. When one of the interrupts (enabled) occurs, the next instruction will be fetched from address 008H. Once in the interrupt service routine, the source of an interrupt can be determined by polling the flag bits in RF. The interrupt flag bit must be cleared by instructions before leaving the interrupt service routine and before interrupts are enabled to avoid recursive interrupts.

The flag (except ICIF bit) in the Interrupt Status Register (RF) is set regardless of the status of its mask bit or the execution of ENI. Note that the outcome of RF will be the logic AND of RF and IOCF (refer to figure below). The RETI instruction ends the interrupt routine and enables the global interrupt (the execution of ENI).

When an interrupt is generated by the INT instruction (enabled), the next instruction will be fetched from Address 001H.

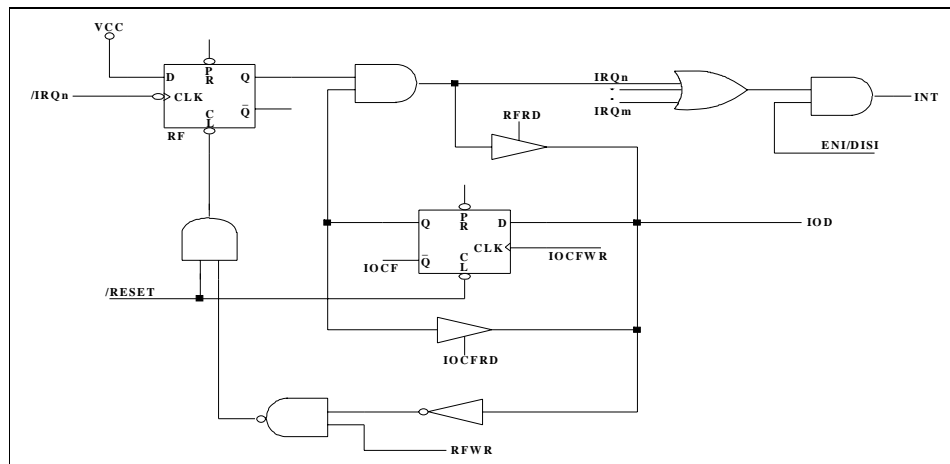

Figure 5-7 Interrupt Input Circuit



## 5.7 Oscillator

### 5.7.1 Oscillator Modes

The EM78P154N can be operated in four different oscillator modes, such as External RC oscillator mode (ERC), Internal RC oscillator mode (IRC), High Crystal oscillator mode (HXT), and Low Crystal oscillator mode (LXT). The desired mode can be selected by programming OSC2, OSC1, and OSC0 in the CODE option register. The Table below describes how these four oscillator modes are defined with OSC2, OSC1, and OSC0.

#### ■ Oscillator Modes Defined by OSC

Mode	OSC2	OSC1	OSC0
ERC (External RC oscillator mode); P55/OSCO act as P55	0	0	0
ERC (External RC oscillator mode); P55/OSCO act as OSC0	0	0	1
IRC (Internal RC oscillator mode) ; P55/OSCO act as P55	0	1	0
IRC (Internal RC oscillator mode); P55/OSCO act as OSC0	0	1	1
MCIRC (Manual calibration IRC mode); P55/OSCO act as P55	1	0	0
MCIRC (Manual calibration IRC mode); P55/OSCO act as OSC0			
LXT (Low Crystal oscillator mode)	1	1	0
HXT (High Crystal oscillator mode) <b>(default)</b>	1	1	1

**Note:** The transient point of system frequency between HXT and LXY is 400kHz.

The maximum operational frequency of the crystal/resonator under different VDDs is as listed below.

#### ■ Summary of Maximum Operating Speeds

Conditions	VDD	Max Freq. (MHz)
Two cycles with two clocks	2.1	4.0
	3.0	8.0
	5.0	20.0



### 5.7.2 Crystal Oscillator/Ceramic Resonators (Crystal)

The EM78P154N can be driven by an external clock signal through the OSCI pin as shown in the following figure.

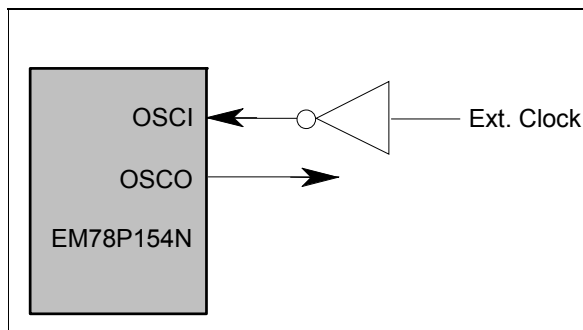

Figure 5-8a External Clock Input Circuit

In the most applications, Pins OSCI and OSCO can be connected with a crystal or ceramic resonator to generate oscillation. The Figure below depicts such circuit. The same thing applies whether it is in the HXT mode or in the LXT mode. The following table provides the recommended values of C1 and C2. Since each resonator has its own attribute, refer to its specification for appropriate values of C1 and C2. RS, a serial resistor, may be necessary for AT strip cut crystal or low frequency mode.

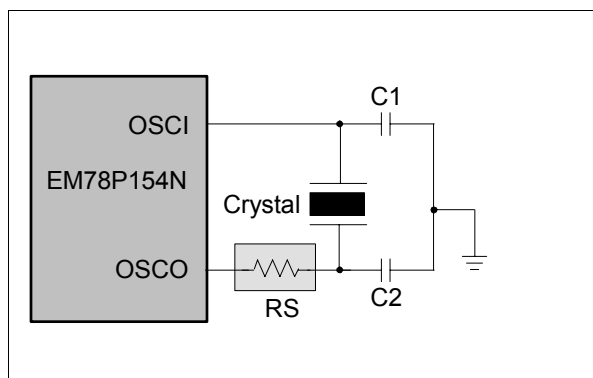

Figure 5-8b Crystal/Resonator Circuit

#### ■ Capacitor Selection Guide for Crystal Oscillator or Ceramic Resonator

Oscillator Type	Frequency Mode	Frequency	C1 (pF)	C2 (pF)
Ceramic Resonators	HXT	455kHz	100~150	100~150
		2.0 MHz	20~40	20~40
		4.0 MHz	10~30	10~30
Crystal Oscillator	LXT	32.768kHz	25	15
		100kHz	25	25
		200kHz	25	25
	HXT	455kHz	20~40	20~150
		1.0MHz	15~30	15~30
		2.0MHz	15	15
		4.0MHz	15	15

**Note:** The values of capacitors C1 and C2 are for reference only

### 5.7.3 External RC Oscillator Mode

For some applications that do not require a very precise timing calculation, the RC oscillator (Figure 5-9 below) offers a cost-effective oscillator configuration. Nevertheless, it should be noted that the frequency of the RC oscillator is influenced by the supply voltage, the values of the resistor ( $R_{ext}$ ), the capacitor ( $C_{ext}$ ), and even by the operation temperature. Moreover, the frequency also changes slightly from one chip to another due to manufacturing process variations.

In order to maintain a stable system frequency, the values of the  $C_{ext}$  should not be less than 20pF, and that the value of  $R_{ext}$  should not be greater than 1 M $\Omega$ . If they cannot be kept in this range, the frequency can be easily affected by noise, humidity, and leakage.

The smaller the  $R_{ext}$  in the RC oscillator is, the faster its frequency will be. On the contrary, for very low  $R_{ext}$  values, for instance, 1 K $\Omega$ , the oscillator becomes unstable because the NMOS cannot discharge the current of the capacitance correctly.

Based on the above reasons, it must be kept in mind that all of the supply voltage, the operation temperature, the components of the RC oscillator, the package types, the way the PCB is layout, will affect the system frequency.

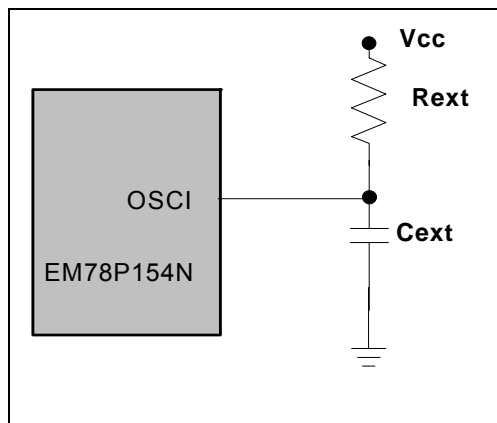

Figure 5-9 External RC Oscillator Mode Circuit



■ **RC Oscillator Frequencies**

Cext	Rext	Average Fosc 5V, 25°C	Average Fosc 3V, 25°C
20 pF	3.3k	3.92 MHz	3.65 MHz
	5.1k	2.67 MHz	2.60 MHz
	10k	1.39MHz	1.40 MHz
	100k	149 kHz	156 kHz
100 pF	3.3k	1.39 MHz	1.33 MHz
	5.1k	940 kHz	920 kHz
	10k	480 kHz	475 kHz
	100k	52 kHz	50 kHz
300 pF	3.3k	595 kHz	560 kHz
	5.1k	400 kHz	390 kHz
	10k	200 kHz	200 kHz
	100k	21 kHz	20 kHz

**NOTE:** <sup>1</sup>: Measured based on DIP packages.  
<sup>2</sup>: The values are for design reference only.  
<sup>3</sup>: The frequency drift is  $\pm 30\%$ .

**5.7.4 Internal RC Oscillator Mode**

EM78P154N offers a versatile internal RC mode with default frequency value of 4MHz. The Internal RC oscillator mode has other frequencies (1MHz, 8MHz, & 455kHz) that can be set by Code Option (Word 1), RCM1, and RCM0. All these four main frequencies can be calibrated by programming the the Option Bits C3 ~ C0. The table below describes a typical instance of the calibration.

■ **Internal RC Drift Rate (Ta=25°C, VDD=3.9V±5%, VSS=0V)**

Internal RC Frequency	Drift Rate			
	Temperature (-40°C ~ +85°C)	Voltage (2.3V ~ 5.5V)	Process	Total
4MHz	±5%	±5%	±4%	±14%
8MHz	±5%	±5%	±4%	±14%
1MHz	±5%	±5%	±4%	±14%
455MHz	±5%	±5%	±4%	±14%

**Note:** These are theoretical values which are provided for reference only. Actual values may vary depending on the actual process.



**Calibration Selection for Internal RC Mode**

C3	C2	C1	C0	Cycle Time (ns)	Frequency (MHz)
0	0	0	0	390.6	2.56
0	0	0	1	365.0	2.74
0	0	1	0	342.5	2.92
0	0	1	1	322.6	3.1
0	1	0	0	304.9	3.28
0	1	0	1	289.0	3.46
0	1	1	0	274.7	3.64
0	1	1	1	261.8	3.82
1	1	1	1	250.0	4.00
1	1	1	0	239.2	4.18
1	1	0	1	229.4	4.36
1	1	0	0	220.3	4.54
1	0	1	1	211.9	4.72
1	0	1	0	204.1	4.9
1	0	0	1	196.7	5.08
1	0	0	0	190.1	5.26

**Note:** These are theoretical values which are provided for reference only. Actual values may vary depending on the actual process.

## 5.8 Code Option Register

The EM78P154N has a Code Option word that is not a part of the normal program memory. The option bits cannot be accessed during normal program execution.

■ **Code Option Register and Customer ID Register Arrangement Distribution:**

Word 0	Word 1	Word 2
Bit 12 ~ Bit 0	Bit 12 ~ Bit 0	Bit 12 ~ Bit 0

### 5.8.1 Code Option Register (Word 0)

Word 0												
Bit 12	Bit 11	Bit 10	Bit 9	Bit 8	Bit 7	Bit 6	Bit 5	Bit 4	Bit 3	Bit 2	Bit 1	Bit 0
-	-	-	-	CLKS0	ENWDTB	OSC2	OSC1	OSC0	HLP	PR2	PR1	PR0

**Bit 0 ~ Bit 2 (PR0 ~ PR2):** Protect bits

PR0 ~ PR2 are protect bits. Protect types are as follows:

PR2	PR1	PR0	Protect
0	0	0	Enable
0	0	1	Enable
0	1	0	Enable
0	1	1	Enable
1	0	0	Enable
1	0	1	Enable
1	1	0	Enable
1	1	1	Disable



**Bit 3 (HLP):** Power selection  
**0** = Low power  
**1** = High power

**Bit 4 ~ Bit 6 (OSC0 ~ OSC2):** Oscillator Modes Selection bits

Mode		OSC2	OSC1	OSC0
ERC (External RC oscillator mode); P55/OSCO act as P55		0	0	0
ERC (External RC oscillator mode); P55/OSCO act as OSCO		0	0	1
IRC (Internal RC oscillator mode) ; P55/OSCO act as P55		0	1	0
IRC (Internal RC oscillator mode); P55/OSCO act as OSCO		0	1	1
MCIRC (Manual calibration IRC mode); P55/OSCO act as P55	With Simulator only	1	0	0
MCIRC (Manual calibration IRC mode); P55/OSCO act as OSCO		1	0	1
LXT (Low Crystal oscillator mode)		1	1	0
HXT (High Crystal oscillator mode) <b>(default)</b>		1	1	1

**Note:** The transient point of system frequency between HXT and LXY is 400kHz.

**Bit 7 (ENWDTB):** Watchdog timer enable bit  
**0** = Enable  
**1** = Disable

**Bit 8 (CLKS0):** Instruction period option bit

Word 0	CLK0
4 oscillator time periods <b>(default)</b>	1
2 oscillator time periods	0

Refer to Section 4.12, *Instruction Set* for further details.

**Bit 9 ~ Bit 12:** Not used, but need to be set to "1" all the time to avoid possible error.

### 5.8.2 Customer ID Register (Word 1)

WORD 0												
Bit12	Bit11	Bit10	Bit9	Bit8	Bit7	Bit6	Bit5	Bit4	Bit3	Bit2	Bit1	Bit0
-	RCOUT	-	-	-	-	CYES	-	-	-	-	RCM1	RCM0

**Bit 0 ~ Bit 1 (RCM0 ~ RCM1):** IRC mode selection bits

RCM 1	RCM 0	Frequency (MHz)
1	1	4
1	0	8
0	1	1
0	0	455kHz

**Bit 2 ~ Bit 5:** Not used

- Bit 6 (CYES):** Instruction cycle selection bit  
**0** = one instruction cycle  
**1** = two instruction cycles (default)
- Bit 7 ~ Bit 10:** Not used
- Bit 11 (RCOUT):** System clock output enable bit in IRC or ERC mode  
**0** = OSCO pin is open drain  
**1** = OSCO output system clock
- Bit 12:** Not used

### 5.8.3 Customer ID Register (Word 2)

Word 0												
Bit12	Bit11	Bit10	Bit9	Bit8	Bit7	Bit6	Bit5	Bit4	Bit3	Bit2	Bit1	Bit0
-	-	-	-	-	-	-	-	-	-	-	-	-

**Bit 0 ~ Bit 12:** User's ID code

## 5.9 Power-on Considerations

Any microcontroller is not guaranteed to start to operate properly before the power supply has stabilized.

The EM78P154N POR voltage range is 1.7V~1.9V. Under customer application, when power is OFF, V<sub>dd</sub> must drop to below 1.2V and remains OFF for 10μs before power can be switched ON again. This way, the EM78P154N will reset and operates normally. The extra external reset circuit will work well if V<sub>dd</sub> can rise at very fast speed (50 ms or less). However, under most cases where critical applications are involved, extra devices are required to assist in solving the power-up problems.

## 5.10 External Power-on Reset Circuit

The circuit shown in the figure implements an external RC to produce the reset pulse. The pulse width (time constant) should be kept long enough for V<sub>dd</sub> to reach minimum operation voltage. This circuit is used when the power supply has a slow rise time. Since the current

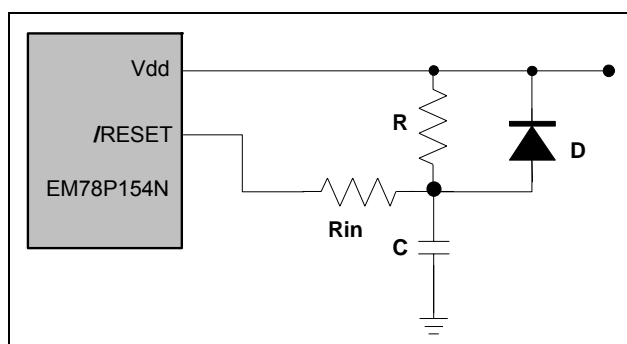

Figure 5-10 External Power-up Reset Circuit

leakage from the /RESET pin is about ±5μA, it is recommended that R should not be greater than 40K. In this way, the /RESET pin voltage is held below 0.2V. The diode (D) acts as a short circuit at the moment of power down. The capacitor C will discharge rapidly and fully. Rin, the current-limited resistor, will prevent high current or ESD (electrostatic discharge) from flowing to pin /RESET.

## 5.11 Residue-Voltage Protection

When the battery is replaced, the device power (Vdd) is cut off but residue-voltage remains. The residue-voltage may trip below the minimum Vdd, but not to zero. This condition may cause a poor power-on reset. The following figures illustrate two recommended methods on how to build a residue-voltage protection circuit for EM78P154N.

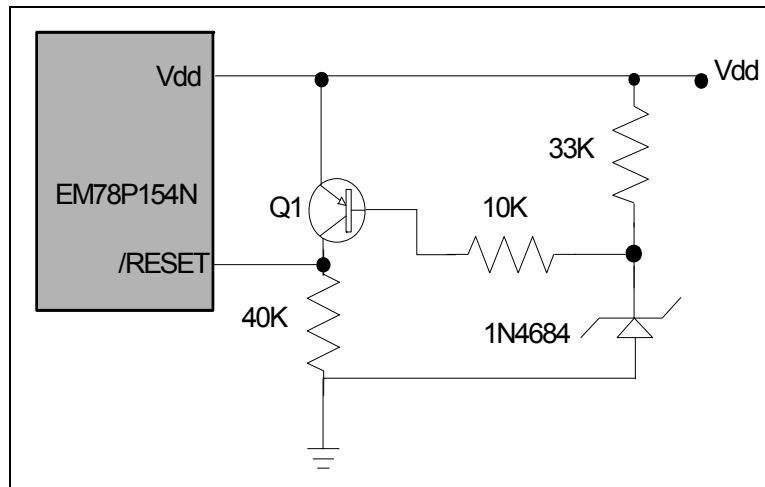

Figure 5-11a Residue Voltage Protection Circuit (1)

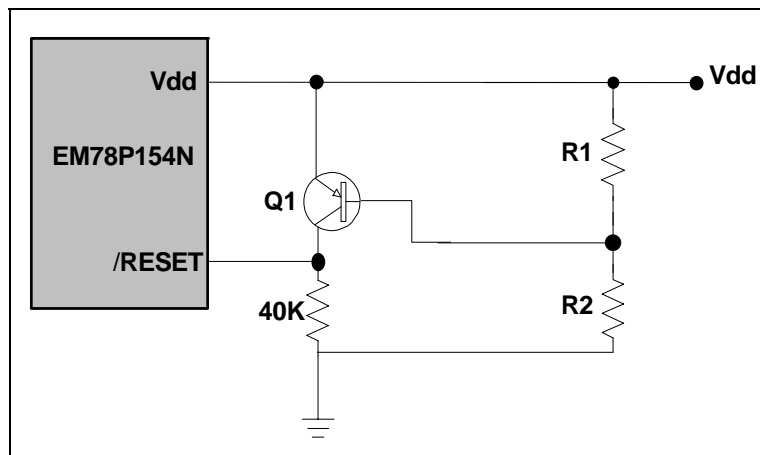

Figure 5-11b Residue Voltage Protection Circuit (2)



## 5.12 Instruction Set

Each instruction in the instruction set is a 13-bit word divided into an OP code and one or more operands. Normally, all instructions are executed within one single instruction cycle (one instruction consists of two oscillator periods), unless the program counter is changed by instruction "MOV R2,A", "ADD R2,A", or by instructions of arithmetic or logic operation on R2 (e.g., "SUB R2,A", "BS(C) R2,6", "CLR R2", ...). In this case, the execution takes two instruction cycles.

If for some reasons, the specification of the instruction cycle is not suitable for certain applications, try modifying the instruction as follows:

- A) Change one instruction cycle to consist of four oscillator periods.
- B) "JMP," "CALL," "RET," "RETL," "RETI," or the conditional skip ("JBS," "JBC," "JZ," "JZA," "DJZ," "DJZA") commands which were tested to be true, are executed within two instruction cycles. The instructions that are written to the program counter also take two instruction cycles.

Case (A) is selected by the Code Option bit, called CLK. One instruction cycle consists of two oscillator clocks if CLK is low; and four oscillator clocks if CLK is high.

Note that once the four oscillator periods within one instruction cycle is selected as in Case (A), the internal clock source to TCC should be  $CLK = Fosc/4$ , instead of  $Fosc/2$ .

Moreover, the instruction set has the following features:

- 1) Every bit of any register can be set, cleared, or tested directly.
- 2) The I/O register can be regarded as general register. That is, the same instruction can operate on I/O register.

The following symbols are used in the Instruction Set table:

**Convention:**

**R** = Register designator that specifies which one of the registers (including operation and general purpose registers) is to be utilized by the instruction.

Bits 6 and 7 in R4 determine the selected register bank.

**b** = Bit field designator that selects the value for the bit located in the register R and which affects the operation.

**k** = 8 or 10-bit constant or literal value

Binary Instruction	Hex	Mnemonic	Operation	Status Affected
0 0000 0000 0000	0000	NOP	No Operation	None
0 0000 0000 0001	0001	DAA	Decimal Adjust A	C
0 0000 0000 0010	0002	CONTW	A → CONT	None
0 0000 0000 0011	0003	SLEP	0 → WDT, Stop oscillator	T, P
0 0000 0000 0100	0004	WDTC	0 → WDT	T, P
0 0000 0000 rrrr	000r	IOW R	A → IOCR	None <sup>1</sup>



Binary Instruction	Hex	Mnemonic	Operation	Status Affected
0 0000 0001 0000	0010	ENI	Enable Interrupt	None
0 0000 0001 0001	0011	DISI	Disable Interrupt	None
0 0000 0001 0010	0012	RET	[Top of Stack] → PC	None
0 0000 0001 0011	0013	RETI	[Top of Stack] → PC, Enable Interrupt	None
0 0000 0001 0100	0014	CONTR	CONT → A	None
0 0000 0001 rrrr	001r	IOR R	IOCR → A	None <sup>1</sup>
0 0000 01rr rrrr	00rr	MOV R,A	A → R	None
0 0000 1000 0000	0080	CLRA	0 → A	Z
0 0000 11rr rrrr	00rr	CLR R	0 → R	Z
0 0001 00rr rrrr	01rr	SUB A,R	R-A → A	Z, C, DC
0 0001 01rr rrrr	01rr	SUB R,A	R-A → R	Z, C, DC
0 0001 10rr rrrr	01rr	DECA R	R-1 → A	Z
0 0001 11rr rrrr	01rr	DEC R	R-1 → R	Z
0 0010 00rr rrrr	02rr	OR A,R	A ∨ R → A	Z
0 0010 01rr rrrr	02rr	OR R,A	A ∨ R → R	Z
0 0010 10rr rrrr	02rr	AND A,R	A & R → A	Z
0 0010 11rr rrrr	02rr	AND R,A	A & R → R	Z
0 0011 00rr rrrr	03rr	XOR A,R	A ⊕ R → A	Z
0 0011 01rr rrrr	03rr	XOR R,A	A ⊕ R → R	Z
0 0011 10rr rrrr	03rr	ADD A,R	A + R → A	Z, C, DC
0 0011 11rr rrrr	03rr	ADD R,A	A + R → R	Z, C, DC
0 0100 00rr rrrr	04rr	MOV A,R	R → A	Z
0 0100 01rr rrrr	04rr	MOV R,R	R → R	Z
0 0100 10rr rrrr	04rr	COMA R	/R → A	Z
0 0100 11rr rrrr	04rr	COM R	/R → R	Z
0 0101 00rr rrrr	05rr	INCA R	R+1 → A	Z
0 0101 01rr rrrr	05rr	INC R	R+1 → R	Z
0 0101 10rr rrrr	05rr	DJZA R	R-1 → A, skip if zero	None
0 0101 11rr rrrr	05rr	DJZ R	R-1 → R, skip if zero	None
0 0110 00rr rrrr	06rr	RRCA R	R(n) → A(n-1), R(0) → C, C → A(7)	C
0 0110 01rr rrrr	06rr	RRC R	R(n) → R(n-1), R(0) → C, C → R(7)	C
0 0110 10rr rrrr	06rr	RLCA R	R(n) → A(n+1), R(7) → C, C → A(0)	C
0 0110 11rr rrrr	06rr	RLC R	R(n) → R(n+1), R(7) → C, C → R(0)	C
0 0111 00rr rrrr	07rr	SWAPA R	R(0-3) → A(4-7), R(4-7) → A(0-3)	None
0 0111 01rr rrrr	07rr	SWAP R	R(0-3) ↔ R(4-7)	None



Binary Instruction	Hex	Mnemonic	Operation	Status Affected
0 0111 10rr rrrr	07rr	JZA R	R+1 → A, skip if zero	None
0 0111 11rr rrrr	07rr	JZ R	R+1 → R, skip if zero	None
0 100b brrr rrrr	0xxx	BC R,b	0 → R(b)	None <sup>2</sup>
0 101b brrr rrrr	0xxx	BS R,b	1 → R(b)	None <sup>3</sup>
0 110b brrr rrrr	0xxx	JBC R,b	if R(b)=0, skip	None
0 111b brrr rrrr	0xxx	JBS R,b	if R(b)=1, skip	None
1 00kk kkkk kkkk	1kkk	CALL k	PC+1 → [SP], (Page, k) → PC	None
1 01kk kkkk kkkk	1kkk	JMP k	(Page, k) → PC	None
1 1000 kkkk kkkk	18kk	MOV A,k	k → A	None
1 1001 kkkk kkkk	19kk	OR A,k	A ∨ k → A	Z
1 1010 kkkk kkkk	1Akk	AND A,k	A & k → A	Z
1 1011 kkkk kkkk	1Bkk	XOR A,k	A ⊕ k → A	Z
1 1100 kkkk kkkk	1Ckk	RETL k	k → A, [Top of Stack] → PC	None
1 1101 kkkk kkkk	1Dkk	SUB A,k	k-A → A	Z, C,DC
1 1110 0000 0001	1E01	INT	PC+1 → [SP], 001H → PC	None
1 1111 kkkk kkkk	1Fkk	ADD A,k	k+A → A	Z, C, DC

**Note:** <sup>1</sup> This instruction is applicable to IOC5~IOC6, IOCB ~ IOCF only.

<sup>2</sup> This instruction is not recommended for RF operation.

<sup>3</sup> This instruction cannot operate under RF.



### 5.13 Timing Diagrams

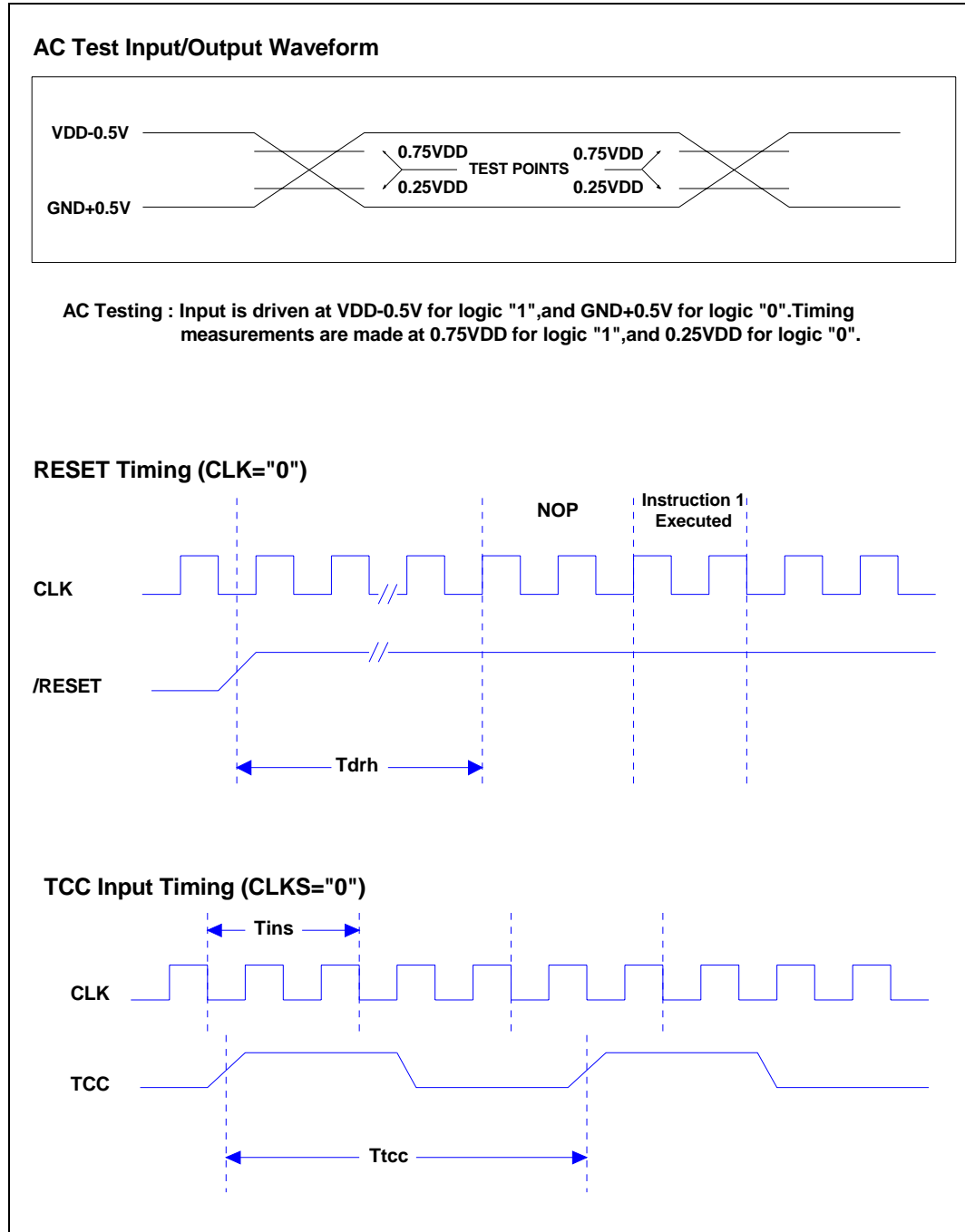

Figure 5-12 EM78P154N Timing Diagrams



## 6 Absolute Maximum Ratings

### ■ EM78P154N

Items	Rating
Temperature under bias	-40°C to 85°C
Storage temperature	-65°C to 150°C
Working voltage	2.1 to 5.5V
Working frequency	DC to 20MHz*
Input voltage	V <sub>ss</sub> -0.3V to V <sub>dd</sub> +0.5V
Output voltage	V <sub>ss</sub> -0.3V to V <sub>dd</sub> +0.5V

Note: \* These parameters are theoretical values and have not been tested.

## 7 Electrical Characteristics

### 7.1 DC Characteristic

T<sub>a</sub>=25 °C, V<sub>DD</sub>=5V±5%, V<sub>SS</sub>=0V

Symbol	Parameter	Condition	Min.	Typ.	Max.	Unit
FXT	Crystal: VDD to 3V	Two cycle with two clocks	DC		8.0	MHz
	Crystal: VDD to 5V	Two cycle with two clocks	DC		20.0	MHz
ERC	ERC: VDD to 5V	R: 5.1KΩ, C: 100 pF	F±30%	940	F±30%	kHz
IIL	Input Leakage Current for input pins	VIN = VDD, VSS			±1	μA
VIH1	Input High Voltage (VDD=5V)	Ports 5, 6 (Schmitt trigger)	0.75V <sub>dd</sub>		V <sub>dd</sub> +0.3	V
VIL1	Input Low Voltage (VDD=5V)	Ports 5, 6 (Schmitt trigger)	V <sub>dd</sub> -0.3		0.25V <sub>dd</sub>	V
VIHT1	Input High Threshold Voltage (VDD=5V)	/RESET, TCC (Schmitt trigger)	0.75V <sub>dd</sub>		V <sub>dd</sub> +0.3	V
VILT1	Input Low Threshold Voltage (VDD=5V)	/RESET, TCC (Schmitt trigger)	V <sub>dd</sub> -0.3		0.25V <sub>dd</sub>	V
VIHX1	Clock Input High Voltage (VDD=5V)	OSCI (Schmitt trigger)	0.75V <sub>dd</sub>		V <sub>dd</sub> +0.3	V
VILX1	Clock Input Low Voltage (VDD=5V)	OSCI (Schmitt trigger)	V <sub>dd</sub> -0.3		0.25V <sub>dd</sub>	V
VIH2	Input High Voltage (VDD=3V)	Ports 5, 6 (Schmitt trigger)	0.75V <sub>dd</sub>		V <sub>dd</sub> +0.3	V
VIL2	Input Low Voltage (VDD=3V)	Ports 5, 6 (Schmitt trigger)	V <sub>dd</sub> -0.3		0.25V <sub>dd</sub>	V
VIHT2	Input High Threshold Voltage (VDD=3V)	/RESET, TCC (Schmitt trigger)	0.75V <sub>dd</sub>		V <sub>dd</sub> +0.3	V
VILT2	Input Low Threshold Voltage (VDD=3V)	/RESET, TCC (Schmitt trigger)	V <sub>dd</sub> -0.3		0.25V <sub>dd</sub>	V
VIHX2	Clock Input High Voltage (VDD=3V)	OSCI (Schmitt trigger)	0.75V <sub>dd</sub>		V <sub>dd</sub> +0.3	V
VILX2	Clock Input Low Voltage (VDD=3V)	OSCI (Schmitt trigger)	V <sub>dd</sub> -0.3		0.25V <sub>dd</sub>	V
VOH1	Output High Voltage (Ports 5)	IOH = -6 mA	4.5			V
VOH1	Output High Voltage (Ports 6) (Schmitt trigger)	IOH = -6 mA	4.5			V
VOL1	Output Low Voltage (Port5)	IOL = 16.5 mA			0.5	V
VOL1	Output Low Voltage (Ports 6) (Schmitt trigger)	IOL = 16.5 mA			0.5	V
IPH	Pull-high current	Pull-high active, input pin at VSS	-50	-70	-100	μA
IPD	Pull-down current	Pull-down active, input pin at VDD	25	50	120	μA



Symbol	Parameter	Condition	Min.	Typ.	Max.	Unit
ISB1	Power down current (VDD=5.0V)	All input and I/O pins at VDD, output pin floating, WDT disabled	-	1	2	μA
ISB2	Power down current (VDD=5.0V)	All input and I/O pins at VDD, output pin floating, WDT enabled	-	6	10	μA
ICC1	Operating supply current (VDD=3V) at two cycles/four clocks	/RESET= 'High', Fosc=32kHz (Crystal type, CLKS="0"), output pin floating, WDT disabled	-	20	30	μA
ICC2	Operating supply current (VDD=3V) at two cycles/four clocks	/RESET= 'High', Fosc=32KHz (Crystal type, CLKS="0"), output pin floating, WDT enabled	-	22	32	μA
ICC3	Operating supply current (VDD=5.0V) at two cycles/two clocks	/RESET= 'High', Fosc=4MHz (Crystal type, CLKS="0"), output pin floating, WDT enabled	-	1.7	2.5	mA
ICC4	Operating supply current (VDD=5.0V) at two cycles/four clocks	/RESET= 'High', Fosc=10MHz (Crystal type, CLKS="0"), output pin floating, WDT enabled	-	2.7	3.5	mA

Note: \* These parameters are theoretical values and have not been tested.

## 7.2 AC Characteristic

Ta=25°C, VDD=5V ± 5%, VSS=0V

Symbol	Parameter	Conditions	Min.	Typ.	Max.	Unit
Dclk	Input CLK duty cycle	-	45	50	55	%
Tins	Instruction cycle time (CLKS="0")	Crystal type	100	-	DC	ns
		RC type	500	-	DC	ns
Ttcc	TCC input period	-	(Tins+20)/N*	-	-	ns
Tdrh	Device reset hold time	-	11.8	16.8	21.8	ms
Trst	/RESET pulse width	Ta = 25°C	2000	-	-	ns
Twdt	Watchdog timer period	Ta = 25°C	11.8	16.8	21.8	ms
Tset	Input pin setup time	-	-	0	-	ns
Thold	Input pin hold time	-	-	20	-	ns
Tdelay	Output pin delay time	Cload=20pF	-	50	-	ns

NOTE: These parameters are theoretical values and have not been tested.

\* N = selected prescaler ratio

## APPENDIX

### A Package Type

OTP MCU	Package Type	Pin Count	Package Size
EM78P154NP	DIP	14	300 mil
EM78P154NM	SOP	14	150 mil

### B Package Information

- 14-Lead Plastic Dual in line (PDIP) — 300 mil

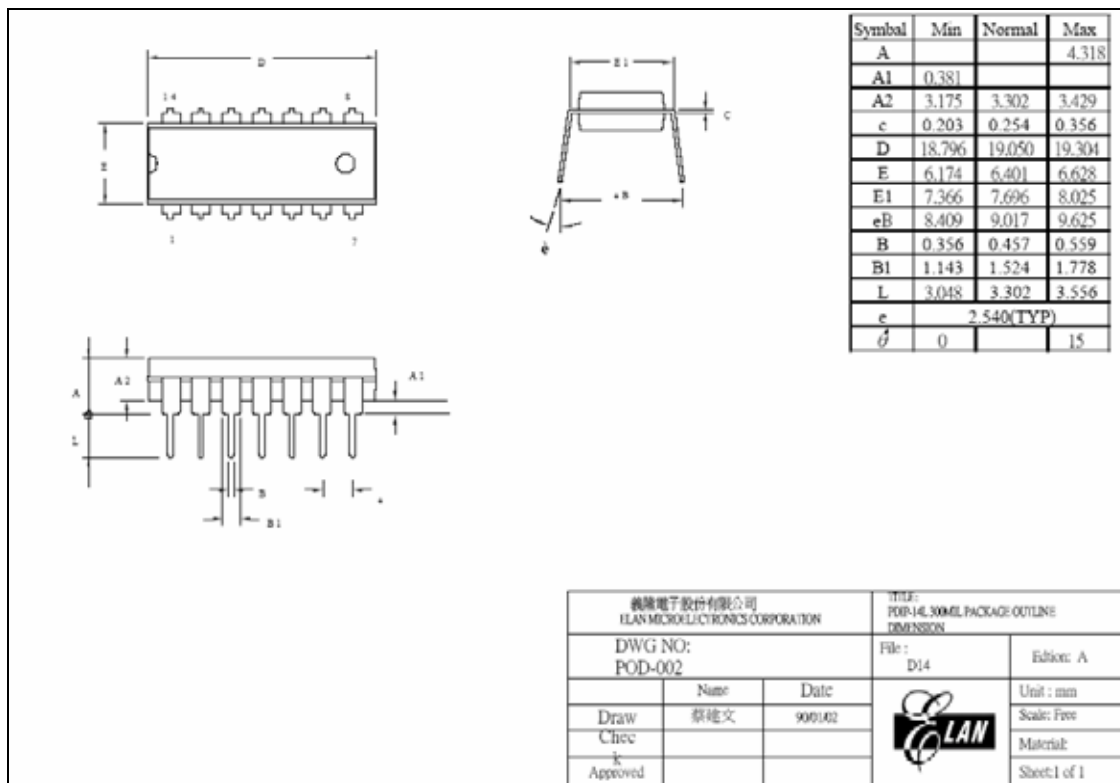

Figure B-1a EM78P154N 14-Lead PDIP Package Type

■ 14-Lead Plastic Dual in line (SOP) — 150 mil

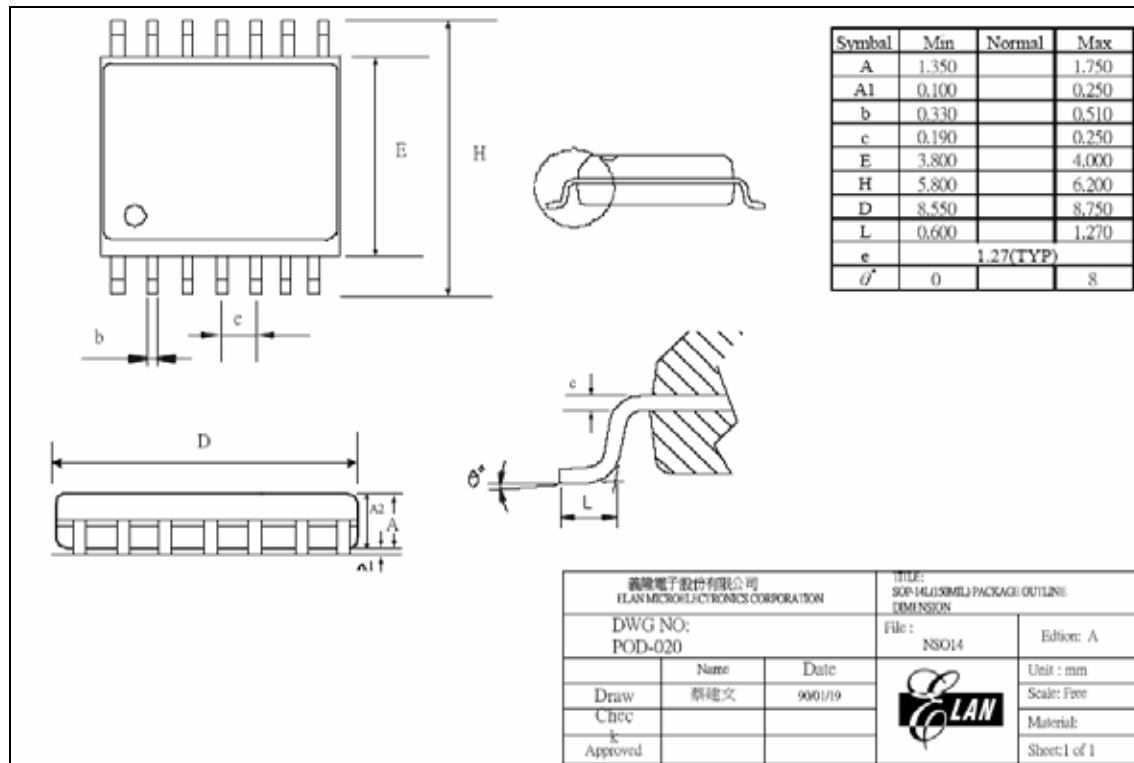

Figure B-1b EM78P154N 14-Lead SOP Package Type



## C Quality Assurance and Reliability

### C.1 Reliability Test

Test Category	Test Conditions	Remarks
Solderability	Solder temperature = $245 \pm 5^\circ\text{C}$ for 5 seconds up to the stopper using a rosin-type flux	
Pre-condition	Step 1: TCT $65^\circ\text{C}$ (15mins) ~ $150^\circ\text{C}$ (15mins), 10 cycles	For SMD IC (such as SOP, QFP, SOJ, etc.)
	Step 2: bake $125^\circ\text{C}$ , TD (endurance) = 24 hrs.	
	Step 3: soak $30^\circ\text{C}$ /60%, TD (endurance) = 192hrs.	
	Step 4: IR flow 3cycles (Pkg thickness $\geq 2.5\text{mm}$ or Pkg volume $\geq 350\text{mm}^3$ -- $225 \pm 5^\circ\text{C}$ ) (Pkg thickness $\leq 2.5\text{mm}$ or Pkg volume $\leq 350\text{mm}^3$ -- $240 \pm 5^\circ\text{C}$ )	
Temperature cycle test	$-65^\circ\text{C}$ (15mins) ~ $150^\circ\text{C}$ (15mins), 200 cycles	
Pressure cooker test	TA = $121^\circ\text{C}$ , RH = 100%, pressure = 2atm, TD (endurance) = 96 Hrs.	
High temperature /high humidity test	TA = $85^\circ\text{C}$ , RH = 85%, TD (endurance) = 168, 500 Hrs	
High-temperature storage life	TA = $150^\circ\text{C}$ , TD (endurance) = 500, 1000Hrs.	
High-temperature operating life	TA = $125^\circ\text{C}$ , VCC = Max. operating voltage, TD (endurance) = 168,500, 1000Hrs.	
Latch-up	TA = $25^\circ\text{C}$ , VCC = Max. operating voltage, 150mA/20V	
ESD (HBM)	TA = $25^\circ\text{C}$ , $\geq \pm 3\text{KV}$	IP_ND, OP_ND, IO_ND IP_NS, OP_NS, IO_NS
ESD (MM)	TA = $25^\circ\text{C}$ , $\geq \pm 300\text{V}$	IP_PD, OP_PD, IO_PD, IP_PS, OP_PS, IO_PS, VDD-VSS(+), VDD_VSS(-)mode



## C.2 Power-on Reset and Vdd Voltage Drop/Rise Timing Test

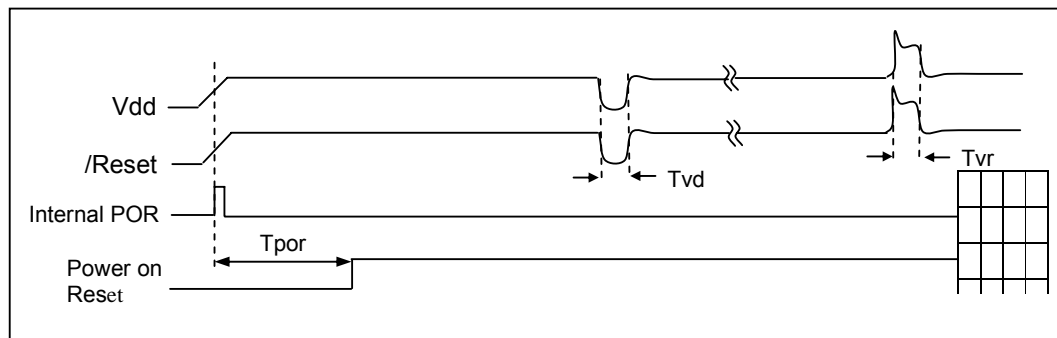

Figure C-1 EM78P154N Power-On Reset and Vdd Voltage Drop/Rise Timing Test Timing Diagram

Symbol	Parameter	Condition	Min.	Typ.	Max.	Unit
Tpor	Power on reset time	Vdd = 5V, -40°C to 85°C	10.5	16.8	22	ms
Tvd*	Vdd Voltage drop time	Vdd = 5V, -40°C to 85°C	-	-	1	µs
Tvr**	Vdd Voltage rise time	Vdd = 5V, -40°C to 85°C	-	-	1	us

**Note:** \* Tvd is the period of Vdd voltage lower than POR voltage.

\*\* Tvr is the period of Vdd voltage higher than 5.5V.

## C.3 Address Trap Detect

An address trap detect is one of the fail-safe function that detects CPU malfunction caused by noise or the like. If the CPU attempts to fetch an instruction from a part of RAM, an internal recovery circuit will be auto started. Until CPU got the correct function, it will execute the next program.